



Specifications and Tolerances for Reference Standards and Field Standards Weights and Measures

Specifications and Tolerances for Graduated Neck Type Volumetric Field Standards

Editors:

L. F. Eason (Contract)
Georgia L. Harris
Val R. Miller

Carol Hockert, Chief
Weights and Measures Division
National Institute of Standards and Technology
Gaithersburg, MD 20899-2600

U. S. Department of Commerce
Gary Locke, Secretary

**National Institute of
Standards and Technology**
Patrick D. Gallagher, Director

NIST
Handbook **105-3**

February 2010 Edition
Supersedes June 1997 Edition

Certain commercial entities, equipment, or materials may be identified in this document in order to describe an experimental procedure or concept adequately. Such identification is not intended to imply recommendation or endorsement by the National Institute of Standards and Technology, nor is it intended to imply that the entities, materials, or equipment are necessarily the best available for the purpose.

National Institute of Standards and Technology Handbook 105-3, 2010 Edition
Natl. Inst. Stand. Technol. Handb. 105-3, 2010 Ed., 49 pages (February 2010)
CODEN: NIHAE2

WASHINGTON: 2010

Preface

The 2010 revision of Handbook 105-3 includes the following changes since it was last published in 1997:

- No retroactive requirements have been added to this revision of the document.
- The definitions have changed. Volumetric field standards are considered test measures if they are hand held and considered provers when mounted. A number of references and defined terms have been expanded.
- Test measures are described as typically 20 L (5 gal) or smaller instead of 40 L (10 gal) or smaller due to ergonomic concerns. Bottom drain 5 gal (19 L or 20 L) test measures were added.
- High resolution volumetric field standards are no longer covered in the document. Definition of these laboratory volumetric standards is beyond the requirements of NIST Handbook 105-3 and is left to the manufacturer and the laboratory.
- Data plate no longer is required to include reference temperature or material thickness. Method of use only has to be on the scale plate.
- It is the responsibility of the user to ensure that a volumetric field standard is appropriately labeled when necessary to prevent cross contamination of products measured.
- Inside diameter and wall thickness were standardized for sight glasses. Sight glass ID for 10 gallon and smaller is 13.0 mm (0.5 in) and 16.0 mm (approximately 5/8 in) for larger volumetric field standards. The minimum nominal wall thickness for sight glasses is 3.2 mm (approximately 1/8 in).
- Clear coated aluminum allowed for the scale plate material. Markings must be permanent (allows silk screen).
- A non-accredited manufacturer of volumetric field standard must make it clear that calibration is required before use for Weights and Measures applications.
- Scale plate graduations must be no smaller in height than 2 mm (approximately 0.1 in).
- The total span of graduations on volumetric field standards smaller than 3800 L (1000 gal) has to be at least 1.5 % of the nominal volume. For 3800 L (1000 gal) and larger volumetric field standards, the total span of graduations must be at least 1.0 % of nominal volume.
- Three thermometer wells are required for 3800 L (1000 gal) and larger volumetric field standards.
- Fast acting, full port valves (rather than gate valves) are required on drain lines.
- A new requirement for sight flow indicators (near the drain valve) has been added. Though not retroactive, these indicators should be added to existing volumetric field standards anytime a major repair of the standard is performed.

- Provers larger than 20 L (5 gal) used for top load applications are required to have fill pipes.
- Bleed lines are required (instead of bleed valves) on all new provers where air may be entrapped in the dry break coupler and lines going to it.
- The level condition of volumetric field standards must be determined by using levels to plumb the neck rather than depending on the top of the neck to be level. The levels on volumetric field standards will be adjusted to agree with this level condition.
- In harmony with OIML R 120, the tolerances for volumetric field standards (test measures and provers) have been changed to $\pm 0.05\%$ of the nominal capacity. All points on the neck scale must be within this tolerance for the entire volume (not the neck volume). An additional neck uniformity tolerance of 1 minor scale division (subdivision) from the nominal/zero to any point on the scale also applies.
- Values in the four tables have been updated and the minor scale division (subdivision) is defined as the neck uniformity tolerance.
- An optional evaluation checklist has been added to provide a reference for uniform evaluation of volumetric field standards.

NOTE Regarding Units of Measure:

The SI unit of volume is the cubic decimeter (dm^3) or the cubic centimeter (cm^3). The Twelfth General (International) Conference on Weights and Measures redefined the litre [herein spelled liter] as a “special name for the cubic decimeter,” but agreed to permit the continuance of the terms liter (L) and milliliter (mL), except in association with measurements of the highest precision. The commercial measurement system in the United States continues to use gallons and cubic inches for practical applications and manufacturers in this industry continue to use U.S. Customary dimensions. Since commercial applications in the United States use units other than SI or other accepted metric units, this document references common units in current use.

Acknowledgment:

The first edition of this Handbook was written by Blayne C. Keysar of NBS in 1979. The 1997 edition was updated with assistance of Karl Herken (KS). This 2010 edition was finalized through a work group consisting of those who provided comments on draft versions, compilation and draft responses of all comments by Michelle Foncannon, with the final review and editing effort led by L.F. Eason. Special acknowledgment is given to Seraphin Test Measure for preparing updated drawings and schematic diagrams. Thanks are also given to numerous metrologists (of both state and industry laboratories) for their technical review of several drafts.

*Trade names used in this Handbook do not imply recommendation or endorsement by the National Institute of Standards and Technology.

Table of Contents

Preface	iii
NOTE Regarding Units of Measure:	iv
Acknowledgment:	iv
INTRODUCTION	1
1 Scope	1
1.1 “Volumetric Field Standard” Classification	1
1.1.1 Test Measures	2
1.1.2 Provers	2
1.2 Laboratory Standards	2
1.2.1 High-Resolution Type	2
1.3 Retroactivity	2
1.4 Future Designs	3
1.5 Safety Considerations	3
2. Reference Documents	3
2.1 American Petroleum Institute (API)	3
2.2 American Society for Testing and Materials (ASTM)	3
2.3 Factory Mutual Research (FM)	4
2.4 International Organization for Standardization (ISO)	4
2.5 National Institute of Standards and Technology (NIST)	4
2.6 International Organization of Legal Metrology (OIML)	4
3. Terminology	4
4. Specifications	6
4.1 Physical Size	6
4.1.1 Size Declaration	6
4.1.2 Special Applications	6
4.1.3 Size Limitations	6
4.2 Reference Temperature	6
4.3 Identification Markings	7
4.3.1 Identification Placement	7
4.3.2 Content	7
4.3.3 Limitations on Use	8
4.4 Material	8
4.4.1 Steel Construction	8
4.4.2 Intended Use Considerations	8
4.4.3 Material and Cross Contamination Safety	8
4.4.4 Non Steel Construction Materials	8
4.5 Physical and Mechanical Properties	9
4.5.1 Body	9
4.5.2 Shape	9
4.5.3 Top and Bottom Cone	9
4.5.4 Neck	9
4.5.5 Sight Glass Gauge Tube	11
4.5.6 Scale Plate Construction	12
4.5.7 Scale Plate Markings	13
4.5.8 Scale Plate Units	14
4.5.9 Scale Plate Graduations	14
4.5.10 Support	15
4.5.11 Thermometer Wells	15
4.5.12 Drains	17
4.5.13 Sight Flow Indicator	17
4.5.14 Minimization of Product Vaporization or Foaming	18
4.5.15 Fill Pipe	18
4.5.16 Bottom Loading	18
4.5.17 Air Entrapment	19

4.5.18	Bleed Line for Prevention of Air Entrapment During Calibration	19
4.5.19	Bleed Valves Not Allowed	20
4.5.20	Vapor Recovery	20
4.5.21	Hardware.....	21
4.5.22	Volumetric Field Standard Leveling.....	22
4.5.23	Levels.....	22
4.6	Workmanship, Finish, and Appearance	23
4.6.1	Finished Quality.....	23
4.6.2	Coatings	24
4.6.3	Ladders and Platforms	24
4.7	Other Requirements	24
4.7.1	Return pump.....	24
4.7.2	Grounding	25
4.7.3	Wiring	25
4.7.4	Electronic Overflow Systems.....	25
4.7.5	Braking System.....	25
4.7.6	Labeling and Placarding.....	25
5.	Tolerances (Maximum Permissible Errors).....	25
5.1	Capacity Tolerance	25
5.2	Neck Tolerance.....	25
5.2.1	Neck Calibration Tolerance	25
5.2.2	Neck Uniformity Tolerance	26
5.3	Adjustment.....	26
6.	Verification Requirements	26
6.1	Legal Requirements	26
6.2	Traceability	26
6.3	Calibration Reports.....	26
6.4	Initial and Periodic Verification	26
6.5	Calibration of Metering Devices.....	27
6.5.1	Using Volumetric Field Standards Without Application of Calibration Correction	27
6.5.2	Using Volumetric Field Standards With Application of Calibration Correction	27
7.	Test Methods and References.....	27
7.1	Calibration Methods	28
7.1.1	NIST IR 7383 Selected Volume Procedures, SOP 18.....	28
7.1.2	NIST IR 7383 Selected Volume Procedures, SOP 19.....	28
7.1.3	API, Manual of Petroleum Measurement Standards	28
7.2	Field Calibrations.....	28
8.	Uncertainties.....	28
8.1	Legal Applications.....	28
8.2	Sources of Variation	29
8.2.1	Accuracy	29
8.2.2	Repeatability	30
Table 1a.	Dimensional requirements for metric volumetric field standards	31
Table 1b.	Dimensional requirement for U.S. customary volumetric field standards	32
Table 2a.	Tolerances and scale plate volumes for metric field standards and provers.....	33
Table 2b.	Tolerances and scale plate volumes for customary volumetric field standards.....	34
Appendix 1.	Optional HB 105-3 Volumetric Field Standard Specifications Checklist.....	35
Figure 1.	Hand-held volumetric field standard (test measure)	37
Figure 2.	Small truck mounted volumetric field standard (prover)	38
Figure 3.	Mounted volumetric field standard (prover)	39
Figure 4.	Sight gauge assembly.....	40
Figure 5.	Trailer mounted volumetric field standard (prover).....	41
Figure 6a.	Limiting vapor loss with fill attached to drain line.	42
Figure 6b.	Limiting vapor loss with fill entering bottom cone.....	42
References	43

SPECIFICATIONS AND TOLERANCES FOR REFERENCE STANDARDS AND FIELD STANDARD WEIGHTS AND MEASURES

3. Specifications and Tolerances for Graduated Neck Type Volumetric Field Standards

These specifications and tolerances are recommended as minimum requirements for standards used by state and local weights and measures officials and others in the regulatory verification of meters used in quantity determination of liquid commodities. Other users may find this handbook helpful in the design of volumetric standards, but the requirements should not be considered mandatory for special applications outside of the scope of regulatory weights and measures.

Key words: bottom loading; provers; specifications; standards; test measures; tolerances; vapor recovery; volumetric field standards; volumetric specifications and tolerances; weights and measures.

INTRODUCTION

Graduated neck type volumetric field standards (test measures and provers) are used primarily to test liquid measuring devices for compliance with commercial requirements. Use of these standards at all appropriate levels of manufacture, distribution, and weights and measures inspection will help promote accuracy and uniformity in commerce. Volumetric field standards covered by this handbook include standard resolution models only. These include hand-held test measures, free-standing and mounted test measures, and provers. The breadth of topics in this handbook is intended to provide information for manufacturers, calibration staff, and weights and measures officials. Other end users may use this handbook for guidance in the design of special application volumetric standards. Deviations from the design specifications in this handbook may require additional tests to ensure the modified standard design meets the performance requirements of the specific application. Deviations from the requirements of this handbook must be clearly noted on any calibration report stating (or implying) compliance to the standard. References are provided when additional information may be useful to the reader.

1. Scope

1.1 “Volumetric Field Standard” Classification

These specifications are limited to non-pressurized, graduated neck type metal field standards, with or without vapor recovery capabilities where the volume is established between a shut-off valve (or bottom-neck zero graduation) and an upper-neck nominal graduation. The term “volumetric field standard” as used in this publication refers to all sizes in general.

1.1.1 Test Measures

Test measures are small (typically 20 L (5 gal) or smaller) hand-held volumetric measures, with or without a graduated bottom-neck (also called bottom-zero or wet-bottom).

1.1.2 Provers

Provers are large (typically 20 L (5 gal) or larger) bottom-drain volumetric measures with or without a graduated bottom-neck (also called bottom-zero or wet-bottom). Provers may be free-standing or permanently mounted on a truck, platform, or trailer.

1.2 Laboratory Standards

Test measures and provers may be used in a laboratory setting as primary or secondary standards. Additional specifications and tolerances may be applicable in those situations. Slicker plate type laboratory standards are not addressed in this handbook.

1.2.1 High-Resolution Type

High-resolution volumetric standards are considered to be laboratory standards and are outside of the scope of this document. These test measures and provers are designed with a small diameter neck and are used to achieve greater neck volume resolution. This type of volumetric laboratory standard may also be characterized by the terms “high-accuracy,” “high-sensitivity neck,” or by the abbreviation “HSN.” Typically high resolution volumetric standards have approximately twice the resolution (i.e., the scale plate graduations are half as large for the same linear distance) of a normal volumetric field standard of the same nominal volume. Since these high resolution standards are specialty items, the neck diameter, resulting resolution, and other design elements must be specified based on the application, agreed to by both customer and manufacturer, and are generally outside the scope of this handbook.

1.3 Retroactivity

These specifications are not intended to make obsolete those field standards fabricated to meet prior specifications. All new test measures and provers placed in service after March 1, 2010, must meet these requirements prior to certification for regulatory Weights and Measures (legal metrology) use.

Volumetric field standards fabricated to meet prior specifications may be used as long as they 1) maintain the current tolerances, 2) meet calibration repeatability requirement of 0.02 % of nominal volume, and 3) their performance is adequate to meet NIST Handbook 44 fundamental considerations (volumetric correction plus uncertainty is less than one third of the tolerance for the device being tested).

The new requirements in this document are not retroactive. However, it is recommended that volumetric field standards be retrofitted to meet new requirements when major repairs or other modifications are made to an older standard.

Leveling [volumetric field standards](#) (section 4.5.22) to adjust replacement levels shall be performed by *plumbing* the neck on two axes separated by 90 degrees. This method shall be used to establish the reference level condition of all volumetric field standards.

1.4 Future Designs

These specifications are not intended to limit innovation made possible by advances in technology or changes in the commercial field devices they are used to test. All design revisions should be evaluated by NIST Weights and Measures Division for accuracy, repeatability, and suitability for task. Approved design revisions may be included in future editions of this document.

1.5 Safety Considerations

This documentary standard may involve hazardous materials, operations, and equipment and does not purport to address the safety problems associated with its use. It is the responsibility of the user of this standard to establish appropriate safety and health practices and determine the applicability of regulatory limitations prior to use. Specific safety information is documented in the API references. Specific items of safety concern are included in Section 4.7.

Commercial liquid measuring devices, tested with volumetric standards, are typically used to measure quantities of petroleum products. Petroleum products are known hazardous materials and hazardous wastes. The user is encouraged to obtain Material Safety Data Sheets (MSDS) from the manufacturer of any product encountered. Federal, state and local safety and disposal regulations concerning hazardous materials encountered should be reviewed and followed by the user.

2. Reference Documents

2.1 American Petroleum Institute (API)¹

- 2.1.1 Manual of Petroleum Measurement Standards, Chapter 4, Proving Systems.
 - 2.1.1.1 Section 1, Introduction (2005).
 - 2.1.1.2 Section 4, Tank Provers (2005).
 - 2.1.1.3 Section 7, Field-Standard Test Measures (2003).
 - 2.1.1.4 Section 8, Operation of Proving Systems (2007).
 - 2.1.1.5 Section 9, Methods of Calibration for Displacement and Volumetric Tank Provers.
 - 2.1.1.6 Chapter 11, Physical Properties Data (Volume Correction Factors).
 - 2.1.1.7 Chapter 12, Calculation of Static Petroleum Quantities.
- 2.1.2 RP 1004, Bottom Loading and Vapor Recovery for MC-306 and DOT-406 Tank Motor Vehicles.

2.2 American Society for Testing and Materials (ASTM)²

- 2.2.1 D 1250, Standard Guide for Use of the Petroleum Measurement Tables.
- 2.2.2 Table 24, Volume Reduction to 60 °F.
- 2.2.3 Table 24B, Generalized Products, Correction of Volume to 60 °F against Relative Density 60/60 °F.

- 2.2.4 Table 34, Reduction of Volume to 60 °F against S.G. 60/60 °F for Light Petroleum Gases.
- 2.3 **Factory Mutual Research (FM)**³
- 2.4 **International Organization for Standardization (ISO)**⁴
 - 2.4.1 ISO 45 Aircraft Pressure Refueling Connections, 1990.
 - 2.4.2 ISO Guide to the Expression of Uncertainty in Measurement, 1993.
- 2.5 National Fire Protection Association (NFPA)⁵
 - 2.5.1 NFPA 58, Liquefied Petroleum Gas Code.
- 2.6 **National Institute of Standards and Technology (NIST)**⁶
 - 2.6.1 Handbook 44, Specifications, Tolerances, and Other Technical Requirements for Weighing and Measuring Devices, see current edition, published annually.
 - 2.6.2 NISTIR 7383, Selected Procedures for Volumetric Calibrations, 2006.
- 2.7 **International Organization of Legal Metrology (OIML)**⁷
 - 2.7.1 OIML R 117-1 (E), Dynamic Measuring Systems for Liquids Other Than Water; Part 1: Metrological and Technical Requirements, 2007.
 - 2.7.2 OIML R 120, Standard Capacity Measures for Testing Measuring Systems for Liquids Other Than Water, 1996.

3. **Terminology**

Bleed line. A small bore line that automatically prevents air entrapment in a pipe, valve, dry break coupling, or other fitting that is part of the calibrated volume of the field standard during calibration and top loading applications.

Bleed valve. Valve used during calibration and top loading applications to manually release entrapped air from a pipe, valve, or fitting that is part of the calibrated volume of the field standard.

Bottom drain. Volumetric field standard design that permits draining the contained liquid without lifting and tipping the prover. Volumetric field standards with a bottom drain are commonly referred to as *provers*.

Bottom loading. Method of filling a volumetric vessel from below. Intake is made through piping at the bottom part of the vessel with connection through a dry-break coupler (also called a bottom-load adaptor). This method of loading tankers is prevalent at large petroleum terminals and must be used for the volumetric field standards used to test the meters at these terminals.

Bottom-load adaptor. See dry-break coupler.

Capacity, nominal. The nominal capacity of a volumetric field standard is the volume used to designate the test measure or prover (e.g., 5 gal test measure). The nominal volume is defined by the nominal mark on a graduated upper neck gauge on a test measure. The nominal volume is defined between the nominal mark on the graduated upper neck gauge and the lower shut off valve (or zero mark on a lower neck gauge) on a prover.

Cubical coefficient of thermal expansion. Three dimensional expansion or contraction of a material due to temperature change, expressed $^{\circ}\text{C}^{-1}$ or $^{\circ}\text{F}^{-1}$ ($/^{\circ}\text{C}$ or $/^{\circ}\text{F}$).

Dry-break coupler. A spring loaded device on a volumetric field standard that is designed to connect to and disconnect from a loading rack arm or aircraft fueler hose without leaking. The same type of adapter is used on petroleum (or other fluid tankers) to connect to the loading arm or on aircraft to attach to the fueler hose.

“High Resolution” volumetric standard. A standard with a small diameter neck for improved resolution in reading the meniscus. Generally used in the laboratory as a standard or check standard.

Main flow cessation. The moment when a full discharge stream "breaks" and becomes a trickle or a drip.

Plumb. The condition of being perpendicular to a horizontal plane, vertical.

Prover. A mounted volumetric field standard (truck, trailer, or stationary); typically greater than or equal to 20 L (5 gal). Provers are not hand held and bottom drain is implied. Provers may be filled from the top or bottom loading, depending on intended use.

Reference temperature. The temperature at which the measure is intended **to contain** or **to deliver** its nominal capacity.

Sight-flow-indicator. A fitting with windows that allows visual observation of the flow through a pipe.

Submerged fill pipe. Pipe used in top filling to minimize foaming of liquids, such as fuel oil and milk, by discharging the product into the bottom of a prover.

Test measure. A hand held volumetric field standard that is typically less than or equal to 20 L (5 gal) and without a bottom drain.

To contain. An indication that the measure is adjusted to contain its intended volume when filled from its empty and dry condition at a reference temperature. These measures are typically marked “To Contain” or “Contain.” Test measures and provers are generally not used in this condition.

To deliver. An indication that the measure is adjusted to deliver its intended volume when filled from its empty and “wet” condition at a reference temperature. The “wet” condition is obtained by filling the measure to its nominal capacity and emptying it in conformance with procedural requirements, leaving a reproducible reference residual amount of liquid in the measure. Volumetric field standards (test measures and provers) are generally used in this condition. These are typically marked “To Deliver” or “Deliver.”

Tolerance (also Maximum Permissible Error). Extreme value of measurement error, with respect to a known reference quantity value, permitted by specifications or regulations for a given measurement, measuring instrument, or measuring system.

Vapor recovery. A system for entrapping and collecting vapors for return to the tank to prevent expulsion into the atmosphere.

4. Specifications

4.1 Physical Size

4.1.1 Size Declaration

The recommended sizes of metric and U.S. Customary (inch-pound) test measures and provers are shown in Tables 1a, 1b, 2a, and 2b. Nominal volumes in each system are ideally selected in multiples of 1, 2, and 5 (liters or gallons) to facilitate calibration. However, a prover may be built to any size to meet specific needs. Non-standard size volumetric field standards that comply with all other requirements shall be considered to be in full compliance with this standard.

NOTE: Users must ensure that the intended metrology laboratory is able to calibrate non-standard sizes prior to obtaining a new field standard.

4.1.2 Special Applications

Test measures and provers are generally selected to minimize the number of deliveries required for volume transfer calibration. Selection may be for use as a laboratory standard for calibration of other test measures or provers, for calibration of LPG provers, or for calibration of dynamic small volume provers. Fifteen is the maximum recommended number of deliveries from a standard to a prover under test to minimize calibration uncertainties. Selection of provers as laboratory standards should take into consideration the largest size of unknown prover that is likely to be tested.

4.1.3 Size Limitations

The 5000 L (1500 gal) prover, which is the largest of the provers described in this publication, is typically the largest size which can be mounted vertically on a truck or trailer and meet highway height and width requirements. Larger volumetric field standards may be built based on design considerations within this document, but they are not specifically covered. Additional performance, structural integrity, stability, and safety issues applicable to these larger standards, though outside of the scope of this handbook, must be considered.

4.2 Reference Temperature

The temperature at which test measures and provers are referenced during calibration and during use for testing petroleum products is generally 15.56 °C (60 °F). International standards reference petroleum products to 15 °C. Provers may be used for applications other than petroleum products or in areas where a different reference temperature is used for petroleum products. In such cases, the appropriate reference temperature for the application should be identified and used. For example, the reference temperature for provers used in testing milk is 4.44 °C (40 °F).

NOTE: Any time the prover is used at a temperature different than the reference temperature the prover volume *must* be corrected from the reference temperature using the following equation:

$$V_{corrected} = (V_{calibrated} + V_{gauge}) \left[1 + \alpha (t_{indicated} - t_{refS}) \right] \text{ where:}$$

α = cubical coefficient of expansion for the prover material (units must match units used to measure prover temperature and t_{refS});

$t_{indicated}$ = temperature of the prover, typically estimated by measuring the temperature of the prover contents through the thermometer wells, when so equipped;

t_{refS} = reference temperature of prover calibration;

$V_{calibrated}$ = calibrated volume of the prover at the reference temperature;

V_{gauge} = indicated gauge reading at the time of use;

$V_{corrected}$ = actual volume of prover contents when corrected from the reference temperature, t_{refS} .

This temperature correction must be performed to determine the correct volume of the prover at time of use. This temperature correction does not in anyway correct for the expansion/contraction of the measured commodity (commonly known as temperature compensation.)

4.3 Identification Markings

4.3.1 Identification Placement

Identification information shall be engraved, embossed, or affixed by some other permanent means directly on the standard or on a metal plate that is permanently attached to the standard in an area that is relatively protected from damage or normal wear. All lettering shall be permanent, durable, weather resistant, impervious to the liquids the volumetric field standard is intended to measure, and of a contrasting color to that of the background. This information (however placed) should be either laminated or coated with a clear protective coating to preserve its legibility indefinitely.

NOTE: The permanence of adhesives used to attach data plates to volumetric field standards has proven to be problematic in the extreme conditions under which these standards are often used. Therefore, the data plate must be attached by weld, solder, or another means that is more permanent than adhesives.

4.3.2 Content

Each standard shall bear in a conspicuous place the following information:

4.3.2.1 Nominal capacity;

4.3.2.2 Name and address of the manufacturer;

4.3.2.3 Model number;

4.3.2.4 Non-repetitive serial or identification number and year of manufacture;

4.3.2.5 Material identification and cubical coefficient of thermal expansion per °C (°F);

4.3.2.6 “10 sec drain after 30 sec delivery” for hand-held volumetric field standards (test measures) or “30 sec drain after main flow cessation” for bottom-drain volumetric field standards (provers).

NOTE: The year of manufacture may be included as part of the serial number if it is easily identifiable to the user.

4.3.3 **Limitations on Use**

Any limitations on use shall be clearly and permanently marked on any volumetric field standard (but not necessarily on the data plate) by either the manufacturer or the user. Examples include volumetric field standards intended to measure accurately only:

- 4.3.3.1 Products having particular properties (e.g., a volumetric field standard for food product testing with a plastic sight glass and alternative reference temperature);
- 4.3.3.2 Under specific installation or operating conditions; or
- 4.3.3.3 When used in conjunction with specific accessory equipment.

4.4 **Material**

4.4.1 **Steel Construction**

Unless approved by the Weights and Measures Division, National Institute of Standards and Technology (NIST), volumetric field standards shall be constructed of low carbon steel or 300-series stainless steel. All parts of a test measure or prover (i.e., neck and integral hardware) shall be made of identical material. Non-integral hardware may be of other materials provided the hardware is durable and suitable for its intended purpose.

4.4.2 **Intended Use Considerations**

Material must be chosen based on intended use and shall be thermally stable. The use of oxygenated fuels, chemicals (e.g., fertilizers, pesticides), or food products may dictate the type of metal that may be used. Laboratory standards should be made of 300 series stainless steel.

NOTE: The materials used in volumetric field standards used for special applications must comply with regulations governing the specific application. In case of conflict, legal requirements supersede the requirements of this handbook.

4.4.3 **Material and Cross Contamination Safety**

Care should be taken to ensure that the materials used for the volumetric field standards, or any subsequent contamination of such materials, do not create a safety hazard, especially when the measures may be used for the measurement of food, petroleum, or chemical products. It is the responsibility of the user to ensure that a volumetric field standard is appropriately labeled when necessary to prevent cross contamination of measured products.

4.4.4 **Non Steel Construction Materials**

Proposals for the exemption of material requirements and for use of other suitable materials must be submitted to the Weights and Measures Division of the National Institute of Standards and Technology (NIST). All applicable physical property data shall be accurately documented for any material chosen. The proposed material will be evaluated to determine the suitability for the intended use, and the requestor will be informed in writing of the decision.

EVALUATION NOTE: An unduly high coefficient of thermal expansion (e.g., such as for plastic or aluminum) is inappropriate for field use in meter verification and will not be approved. Uncorrected thermal expansion introduces an error or uncertainty that is statistically significant.

4.5 **Physical and Mechanical Properties**

4.5.1 **Body**

Any cross section taken in a plane perpendicular to the vertical axis shall be circular. The volume of a standard shall be established without the use of fillers, adjusting plugs, or cavities of any kind.

4.5.2 **Shape**

The shape of the test measure or prover shall ensure complete emptying, draining, and the prevention of air entrapment.

4.5.3 **Top and Bottom Cone**

4.5.3.1 Cone pitch

Recommended top and bottom cone pitches are provided in Tables 1a and 1b. Cone pitches are intended to facilitate complete emptying and draining. The bottom of hand-held test measures shall be concave to prevent the distortion of the measure during filling due to the weight of the liquid.

NOTE: Deviation from the recommended cone pitch requires a laboratory evaluation of repeatability and assurance of no air entrapment. Repeatability criteria requiring the agreement between calibration runs are established in the appropriate calibration procedures. A complete evaluation of repeatability for non-standard cone pitches may require additional runs to verify acceptable repeatability. The metrologist should also examine the surface properties of the cone as roughness will affect drainage characteristics, especially when pitches are less than those specified. Visual examination for places air might be entrapped and agitation of water in the filled vessel to reveal air pockets should be done to ensure there is no air trapped in the volumetric standard.

4.5.3.2 Bottom cone anti-vortex design

An effective anti-vortex device shall be attached to the bottom cone of a prover to minimize liquid swirl during emptying. A prover or test measure must be designed to prevent the trapping of air, whether top or bottom filled.

NOTE 1: Fins or plates are often used to limit circular product motion that creates a vortex.

NOTE 2: Calibration of provers generally requires top filling regardless of top or bottom fill applications to allow for delivery by gravity drain from the laboratory standard.

4.5.3.3 Cone trough

Where a support band extends above the joint between the body of the prover and the top cone, the trough shall have a suitable drain.

4.5.4 **Neck**

The neck (upper and/or lower) of a volumetric field standard shall be inspected for uniformity in its circular cross section. If the graduated section of the neck is “out-of-round” (e.g., oblong or dented), this is indicative of damage and the volumetric standard should be rejected during inspection/calibration by the weights and measures enforcement agency. The neck axis shall be perpendicular to a level horizontal plane.

4.5.4.1 Neck reinforcement

The opening at the top of the neck shall be reinforced to retain a circular cross section by using a rolled bead or a band welded to the neck. As much as practical, this reinforcement and the lip of the neck shall be shaped to facilitate a controlled, single stream pour of liquid from test measures. (See Figures 1, 2, and 3.)

4.5.4.2 Neck diameter

Maximum neck diameters are specified in Tables 1a and 1b. Neck diameters may vary; the critical factors related to neck diameter are the cross sectional area of the fluid in the graduated section of the neck, the volume above and below the nominal zero level, the graduation sizes, the space between graduations, and the clarity and permanence of the markings.

4.5.4.3 Cross sectional area

The cross sectional area of the liquid in the graduated area of the neck of a volumetric field standard is the critical factor in the evaluation of the neck. Therefore, the cross sectional areas of the sight glass and any top fill pipes must also be considered when applicable (i.e., when determining the space between scale plate graduations).

4.5.4.4 Access for cleaning

The neck diameter of a test measure shall be sufficient to permit cleaning and inspection. Small capacity volumetric field standards may have neck diameters that are too small to allow adequate visibility for inspection or space to insert a hand for cleaning. In these cases, a small inspection mirror, fiber optic or miniature camera, and a flexible bottle brush may be necessary to inspect and clean the measure.

4.5.4.5 Neck attachment to cone

The upper neck and lower neck (when present, i.e., bottom zero) shall be attached flush with the cone seam and in such a way that the neck does not project into either cone, thus preventing air or liquid entrapment at the joint.

4.5.4.6 Upper neck drain valve

Volumetric field standards used for meter proving shall not have a drain valve on the upper neck of the standard. Provers used as laboratory standards may have a drain valve on the upper neck to be used for adjusting the delivery from the standard to a nominal volume.

4.5.4.7 Lower neck drain valve

A small drain valve on the gravity discharge line of a volumetric field standard is permitted to adjust the level of a bottom-zero (when present). This drain should be installed before the shut off valve, below the bottom-zero level, and shall not interfere with use of the prover for meter verification.

4.5.4.8 Automated bottom-zero option

Internal piping to the bottom-zero setting valve may be constructed so that the drained level of the liquid is even with the zero level of the lower neck gauge plate. If this is the case, the bottom zero must be adjusted to agree with this fluid level and verified at each calibration.

4.5.4.9 Access to drain

If a lower neck drain valve is present, there must be adequate space for a drain bucket (or other appropriate container) under this valve. Alternatively, the drain valve output may be piped back into the main drain line at a point beyond the shut off valve.

4.5.4.10 Operation

Operator control of the lower neck drain valve must allow simultaneous visibility of the bottom sight gauge.

4.5.5 Sight Glass Gauge Tube

Field standard volumetric standards shall be equipped with a gauge tube mounted on the side of the neck to clearly indicate the level of fluid in the standard.

4.5.5.1 Material

Unless prohibited by the intended application (i.e., testing meters or tanks for milk or other products for human consumption), the gauge tube shall be made of borosilicate glass and be clear and free of any markings, irregularities or defects which distort the appearance of the liquid surface. The “red line” glass tubes common for boiler applications are not acceptable for volumetric field standards.

NOTE: The materials used in volumetric field standards used for special applications must comply with regulations governing the specific application. In case of conflict, those regulations supersede the requirements of this handbook.

4.5.5.2 Diameter and thickness

The sight glass is typically the most fragile part of a volumetric field standard. It is the most likely part to break and need replacement in the field. Sight glass specifications have been standardized to facilitate replacement and ensure the sight glass purchased is durable enough to withstand the normal rigors of use.

4.5.5.3 Sight glass wall thickness

In order to ensure the sight glass is break resistant, a volumetric field standard sight glass wall shall have a minimum nominal thickness of 3.2 mm (approximately 1/8 in).

4.5.5.4 Inside diameter 50 L (10 gal) or smaller

The sight glass gauge tube used on volumetric field standards with a nominal volume 50 L (10 gal) or smaller shall have a nominal inside diameter of 13.0 mm (0.5 in).

4.5.5.5 Inside diameter larger than 50 L (10 gal)

The sight glass gauge tube used on volumetric field standards with a nominal volume larger than 50 L (10 gal) shall have a nominal inside diameter of 16.0 mm (approximately 5/8 in).

NOTE: Care should be taken to ensure that any replacement sight glass meet the wall thickness and inside diameter specifications to maintain the accuracy of the neck scale, for safety, and to reduce the potential for breakage, which could result in leakage of product to the environment.

4.5.5.6 Mounting

The sight glass gauge tube shall be mounted in fittings, which penetrate the cone near the neck (as flush as possible to the neck in order to minimize air entrapment) and, which penetrate the neck near the top of the neck tube (to allow passage of vapors from the tube for vapor recovery purposes). The fitting at the top of the tube may have a removable plug so the tube can be cleaned. The plug shall not interfere with proper vapor equalization (i.e., no pressure build-up that affects the liquid level in the gauge). Removal and replacement of the gauge tube shall be made possible and leak proof by the use of compressible gaskets or "O" rings at both the upper and lower fittings.

4.5.5.7 Shield

On provers where protection of the gauge tube is provided by a shield or cover, the design of the cover shall allow replacement of the gauge tube without difficulty.

4.5.6 Scale Plate Construction

4.5.6.1 Material

The scale plate shall be rigid and resistant to corrosion and discoloration (i.e., anodized aluminum, clear coated aluminum, or stainless steel).

4.5.6.2 Location

The scale plate shall be mounted on a secant to the front of, or slightly in front of the gauge tube. In no case shall it be more than 6 mm (0.236 in) from the tube.

4.5.6.3 Mounting

There shall be a sufficient number of scale brackets (minimum of two) to hold the scale plate(s) firmly. The brackets shall be mounted on two adjusting guide rods using corrosion resistant hardware. Brackets and guide rods shall be constructed of metals that do not generate corrosion and bind the adjustment mechanism. The scale plate(s) shall be securely attached to the brackets and be provided with a means for sealing.

4.5.6.4 Incremental adjustment

Where the design of the scale adjustment provides for the movement of the scale by increments only, the maximum increment shall be less than 25 % of the smallest scale division.

4.5.6.5 Sealing

All adjustments shall be provided with a means for sealing to prevent movement or play. Removal or movement of the adjusting mechanism or scale plates (top and bottom) shall not be possible without breaking the seal. Any gauge movement or play in the adjustment mechanism or scale plates after tightening or sealing the adjustment mechanism shall be less than 25 % of the smallest scale division. Use of sealing material to limit motion of the scale plate is not permitted.

4.5.6.6 Manufacturer's seals on new volumetric field standards

A manufacturer, that is not accredited by an Accreditation Body that is a signatory to the International laboratory Accreditation Cooperation (ILAC) mutual recognition agreement (for the appropriate scope of volume calibration), shall not seal a new volumetric field standard unless a tag attached to the seal (or a label obscuring the view of the sight gauge) clearly states

that calibration is required before the measure can be used for Weights and Measures applications.

4.5.7 **Scale Plate Markings**

4.5.7.1 Scale markings

The graduation lines, numbers, and other inscriptions on the scale plate shall be permanent, durable, weather resistant, impervious to the liquids the volumetric field standard is intended to measure, and of a contrasting color to that of the gauge plate. All letters and numbers on a scale plate shall be legible and of adequate size; in no event smaller in height than 2 mm (approximately 0.1 in).

4.5.7.2 Nominal volume and units indication

Scale plates shall be clearly marked with the nominal volume of the standard and the identification of the unit of measurement used on the scale plate. Proper abbreviations may be used for the unit of measurement (i.e., gal, cu in, in³, L, mL, etc.).

4.5.7.3 Method of use indication

The intended method of use, either “To Contain” or “To Deliver” shall be clearly marked on the scale plate.

4.5.7.4 Nominal and zero lines

The nominal volume or zero lines on all top neck scale plates shall extend across the entire width of the scale plate (except as allowed in the sections of 4.5.8 for [dual unit scale plates](#)) and shall be clearly identified with the nominal volume of the volumetric field standard.

The bottom zero scale plate on provers with a bottom zero shall have a single line extending across the entire width of the scale plate. This line shall be clearly marked as the “zero” or “0” line.

4.5.7.5 Line spacing and width - Major divisions

Major division lines, consistent with Table 2a or 2b depending on the measurement system used, shall be longer than subdivision lines and shall be numbered. The length of the major (numbered) graduation lines on the scale plate shall be no less than 6.0 mm (approximately 0.236 in).

4.5.7.6 Line spacing and width - Subdivisions

Intermediate subdivision lines, consistent with Table 2a or 2b depending on the measurement system used, shall be no less than 3.0 mm (approximately 0.118 in) in length. All lines shall extend to the edge of the scale plate nearest the gauge tube. Graduation lines shall be of uniform width and not more than 0.6 mm (approximately 0.024 in) or less than 0.4 mm (approximately 0.016 in) wide.

4.5.7.7 Graduation spacing

The minimum distance between the center of any adjacent graduations lines shall be 1.6 mm (approximately 1/16 in or 0.0625 in), and the lines shall be evenly spaced.

4.5.8 **Scale Plate Units**

4.5.8.1 Scale units

The basic scale on all standards shall be milliliters or liters on metric volumetric field standards and decimal gallons or cubic inches on U.S. customary volumetric field standards. Scales with identical units on each side of the scale plate may be of one-piece construction and adjustable and sealable as a unit.

4.5.8.2 Dual unit scale plates

A volumetric field standard graduated in multiple (dual) units shall have each nominal capacity mark clearly identified. The units of measure shall also be clearly identified for each scale.

4.5.8.3 Dual units - Two scale plates

If two scale plates are used with dual unit scales, each shall be capable of being adjusted and sealed independently. Both shall be adjusted as close to nominal as possible during calibration.

4.5.8.4 Dual units - Single scale plate

A single piece dual unit scale plate is acceptable as long as the scale units are clearly defined, the two scales are clearly separated, and the conversion between units across the scale plate is accurate.

4.5.8.5 Lack of confusion

Additional care must be taken in the design of any dual scale plate(s) to ensure there is no confusion between units.

4.5.8.6 Dual scale calibration

A calibration report for a volumetric field standard with dual units must include calibration values for both scale plates. If the secondary scale was adjusted based on conversion of the units of the primary scale, it must be clear which scale was adjusted based on the calibration and which was adjusted based on the mathematical conversion (e.g., if a 5 gal prover is calibrated with the nominal value adjusted to 1155.0 in³, the 19 L nominal mark should be adjusted to coincide with the +4.45 in³ indication on the U.S. customary scale plate; this is based on a calculated conversion in which 19 L is approximately 1159.451 in³).

4.5.9 **Scale Plate Graduations**

4.5.9.1 Volumetric field standards less than 3800 L (1000 gal)

For volumetric field standards less than 3800 L (1000 gal), the graduated section of the scale plate shall have a range of at least 1.5 % of the nominal volume of the volumetric field standard.

4.5.9.2 Volumetric field standards 3800 L (1000 gal) or larger

For volumetric field standards 3800 L (1000 gal) or larger, the graduated section of the scale plate shall have a range of at least 1 % of the nominal volume of the volumetric field standard.

4.5.9.3 Nominal capacity mark—Weights and Measures applications

For volumetric field standards used by weights and measures regulatory officials, the nominal capacity mark shall be near the center of the scale with equal volumes graduated above and below the nominal capacity mark. Compliance with this section and the acceptability of the

volumetric field standard for Weights and Measures applications should be listed on any calibration certificate.

4.5.9.4 Nominal capacity mark—Applications other than Weights and Measures

For other users, the nominal capacity mark may be located anywhere on the graduated scale and may have unequal graduated volumes above and below the nominal capacity mark. The range of the graduated scale above and below the nominal capacity mark should be listed on any calibration certificate.

4.5.9.5 Additional graduation ranges

Additional ranges of graduations above and/or below the minimum span of graduations may be included. If included, these additional graduations must meet the tolerances applied to the nominal volume and required graduations.

NOTE: The ideal sight gauge range is dependant on the user's ability to stop the meter delivery while the liquid level is still in the graduated portion of the neck. This ability varies based on various factors including meter flow rate, foaming of the product being metered, the position of the meter control, and various other application specific factors. It is critical that the purchaser of a volumetric field standard understand the specific needs of an application and specify a graduated range that accommodates those needs.

4.5.10 **Support**

The test measure or prover and associated support structure shall be designed to prevent prover distortion and to provide protection against damage when routinely transported on a trailer or truck and when fully loaded.

4.5.10.1 Design

Reinforcing bands, adequate material thickness, or other means of support to the test measure or prover body shall be used to prevent distortion of a standard when it is full of liquid or when it is being transported. The bottom of hand-held test measures shall be concave and of adequate thickness to prevent distortion when filled.

4.5.10.2 Structure

The supporting structure of the volumetric standard consisting of legs, framework, or mounting structure shall not be attached directly to the body of the prover. Legs or other mounting structure must be attached either to an exposed portion of a reinforcing band that extends beyond the body of the prover or to the outside of a reinforcement plate that is attached to the body.

4.5.11 **Thermometer Wells**

4.5.11.1 Hand held volumetric field standards (test measures)

Hand held volumetric field standards (test measures) that have adequate access for a thermometer or temperature probe to be lowered through the neck, are not required to have thermometer wells. The temperature of the liquid should be taken as close as possible to the center (vertically and horizontally) of the cylinder of the test measure main body.

4.5.11.2 Mounted volumetric field standards (provers)

A thermometer well (or wells) shall be installed on the main vessel of all volumetric field standards that are fixed or mounted in place and that have a bottom drain (provers). A well shall

extend at least 20 cm (8 in) into the prover at a downward angle of at least 15 degrees from the horizontal plane to allow a temperature conducting liquid to be poured into the well. The well opening shall protrude 5 cm (2 in) out of the prover and shall be filled with an adequate amount of temperature conducting liquid to cover the sensitive portion of the thermometer of temperature probe that is used.

4.5.11.3 Single well

For provers up to and including 500 L (100 gal), a single well is acceptable. When a single well is installed, it should be located so that its lower (closed) end is at the approximate center of the vertical cross section of the prover.

4.5.11.4 Multiple wells

For provers larger than 380 L (100 gal), multiple wells are required. For provers between 380 L and 3800 L (1000 gal), two wells are required. When two wells are installed, one well end should be near the top and one near the bottom of the cylindrical section. For provers 3800 L (1000 gal) and larger, three wells are required. When three wells are installed, they should be evenly spaced in the upper, middle, and lower portions of the prover and be spaced at two or three points, equally spaced around the circumference of the prover. The average of the individual readings should be used for all temperature related calculations.

4.5.11.5 Exceptions allowed

A thermometer well is not required when liquid tight, chemical resistant, intrinsically safe (required for flammable liquid applications), electronic temperature sensors (typically stainless steel sheathed thermocouple or thermistor probes) or dial face thermometers are installed directly through the wall of a volumetric field standard that meet number, location, depth, and accuracy requirements.

4.5.11.6 Provision for calibration

Any thermometer or temperature probe that is installed in a temperature well or directly in the wall of the volumetric field standard must be easily removable for periodic calibration and replaceable if damaged. Removal of thermometers or temperature probes directly mounted in the wall of the volumetric field standard for calibration requires that the volume of the volumetric field standard be verified after re-installation of the temperature sensing devices. Temperature measurements shall be accurate and traceable to the level required by the applicable device testing requirements covering their range of use.

4.5.11.7 Electronic sensors used inside volumetric field standards

When electronic sensors are used inside the prover either to augment or in lieu of thermometer wells, temperature measurements shall be made at evenly spaced locations at the top, middle, and lower portions of the prover. The average of these readings should be used for all temperature related calculations. Neck temperatures should be avoided since the small volume of the neck is subject to unrepresentative temperature gradients and rapid changes.

4.5.12 **Drains**

4.5.12.1 Gravity discharge line and valve

A gravity discharge line, between the prover and the shut-off valve, shall have a downward slope of at least 5 degrees from the horizontal plane. A gravity discharge line shall consist of a length of pipe, and a fast-acting valve (e.g., butterfly valve or full port ball valve).

NOTE: It has been found that some fast acting full port ball type valves may retain an inconsistent amount of liquid in the body of the valve. This liquid retention could affect the volume and uncertainty of both the calibration of the standard and meter testing in the field. Valves should be evaluated carefully and only those that have minimal liquid retention should be used.

4.5.12.2 Valve operation

All valves shall operate freely and positively and shall not leak under normal operating pressures.

MAINTENANCE NOTE: It has been recommended that butterfly valve O-rings be changed just prior to calibration. However, if the valve is changed, an “as found” calibration value will not be available. Establishing stability data on the volumetric field standard is important. Therefore, routine, pre-calibration valve repair is not recommended. The metrologist should require changing the valve O-rings or other repair if the valve does not perform properly during calibration, regardless of the type of valve.

4.5.12.3 Discharge piping

All gravity and pump discharge lines downstream from the shut-off valve shall be positioned so as to ensure complete emptying of the prover. A gravity discharge line shall have a quick connect fitting to connect the gravity drain or pump-off hose. A quick connect fitting on the gravity line is optional on non-vehicle mounted provers. All discharge lines shall be supported.

4.5.13 **Sight Flow Indicator**

All mounted volumetric field standards (provers) shall have provision made for observing fluid flow immediately upstream or downstream of the shut off valve. Typically this will be by a clear, chemical resistant sight flow indicator device installed on the shut-off valve flange. When possible, installation should be downstream of the shut off valve to facilitate replacement without requiring recalibration.

NOTE: Means for visually observing fluid flow and the empty condition and drain time on a prover is critical for accurate volumetric determination. Listening for a change in the pump sound or a drain ‘gurgle’ to indicate a drained condition is not adequate. It is reliant on the operator’s experience and ability to hear and does not facilitate correct drain times. Moving element indicators (such as a spinning vane) may restrict flow and may not adequately indicate low fluid flows.

Due to the potential for calibration error, systematic differences between calibration and field use, and potential measurement differences between inspectors, all existing mounted volumetric field standards should be modified to add this device before recalibration. If the design of the existing field standard makes this impractical, the sight flow indicator should be added whenever

a major repair is made. When retrofitting existing measures, the sight flow indicator should be installed downstream of the shut off valve to avoid changing the nominal volume.

4.5.14 **Minimization of Product Vaporization or Foaming**

Prover systems (including prover body, hoses, valves, loading mechanisms) shall be designed in such a way as to minimize the volume of product vapor generated and to minimize foaming during loading (regardless of means for loading).

NOTE: Physical means for minimizing foaming or vaporization have included a variety of designs such as bottom loading for petroleum products with lower molecular weight and submerged fill pipes for diesel products; most methods involve means for allowing a quick fill to cover the inlet product flow and even diversion of product (e.g., baffles, diffuser plates) to prevent splashing, circular motion, and turbulence. See figures 6a and 6b for two diagrammatic examples of bottom load positioning designed to minimize vaporization.

4.5.15 **Fill Pipe**

4.5.15.1 Description

A submerged top fill pipe, when used on a volumetric field standard to limit foaming or vapor loss, shall be permanently installed adjacent to the neck or inside the neck if space allows. If mounted external to the neck, it shall pass through the cone and must be provided with a cap. The pipe shall extend to within 10 cm to 15 cm (4 in to 6 in) of the bottom cone. More than one pipe may be installed if necessary. If external to the neck, the top portion of the fill pipe shall be connected to the top portion of the neck by a bleed line in order to prevent the entrapment of air. Fill pipes inside the neck must be left open to the inside of the neck, even when the neck cap is closed. These precautions will allow the pipe to fill with liquid when the prover is being filled by other means, i.e., through the neck or through a bottom load adapter. The affect of the extra neck volume (when mounted outside the neck) or reduction in neck volume (when mounted inside the neck) must be considered in calibration of the scale plate, neck diameter requirements, and graduation readability requirements of this handbook.

4.5.15.2 Fill pipe required for top fill applications

A fill pipe is required for any volumetric field standard with a capacity greater than 20 L (5 gal) that will be used for top fill petroleum applications.

4.5.16 **Bottom Loading**

Meter installations equipped for bottom loading require that a volumetric field standard be fitted with a bottom-load adapter (dry-break coupling) to mate with the loading arm.

This bottom load fill point and bottom loading adapter (dry-break coupling) should duplicate the filling of a tanker compartment as closely as practical. The adapter shall be attached the volumetric standard at any of the following positions:

4.5.16.1 The lower portion of the vertical cylinder section,

4.5.16.2 The lower portion of the cone; or

4.5.16.3 The drain line before the valve and not in the vertical section of the drain.

4.5.16.4 Maximum height

Regardless of attachment location, the vertical height, above grade, of the top of the adapter should not exceed 122 cm (48 in).

NOTE: Examples of possible placement locations are shown in figures 6a and 6b.

4.5.16.5 Bottom Load Adapter Specifications - API loading rack type

A bottom loading adapter for standard bottom loading applications shall comply with American Petroleum Institute RP 1004, "Bottom Loading and Vapor Recovery for MC-306 Tank Motor Vehicle," latest edition.

4.5.16.6 Bottom Load Adapter Specifications - Aircraft fueler

A dry break connector for aircraft fueler applications shall comply with ISO 45, Aircraft Pressure Refueling Connections, 1990.

4.5.16.7 Diverter cone or plate

A diverter cone or plate shall be used to limit turbulence and prevent vaporization. The diverter device should be designed to facilitate the liquid cover of the inlet product flow very quickly and thus reduce vaporization. A diverter cone must be designed with a top vent hole to prevent air entrapment. A diverter plate must be sloped adequately to ensure complete drainage and prevent the entrapment of air. Multiple diverter plates joined together (e.g., an "A frame" design) must have holes along the peak or adequate compound slope to prevent air entrapment.

4.5.17 Air Entrapment

Design and fabrication of volumetric standards shall ensure that no pockets, dents, or crevices are present that could entrap air or liquid, or impair the proper filling or draining of the standard. A partial list of potential problem area examples include:

4.5.17.1 All drainage piping must be routed at a level lower than the shut off valve or the wet bottom zero (if present) to prevent liquid from returning to the prover once the valve is opened.

4.5.17.2 The neck attachment to the upper cone must be smooth with no edge or lip extending into the cone that could trap pockets of air.

4.5.17.3 The sight gauge tube attachment to the upper cone must be smooth with no edge or lip extending into the cone that could trap pockets of air.

4.5.17.4 Any plug or cap on the top of a sight gauge tube must not block the bleed hole or other connection to the neck of the volumetric field standard. Vapor must flow freely from the sight gauge back into the neck of the prover or (if allowed) to atmosphere.

4.5.17.5 In addition to preventing air entrapment while in use, the volumetric field standard piping must be designed to prevent air entrapment when the prover is tested in the calibration laboratory.

4.5.18 Bleed Line for Prevention of Air Entrapment During Calibration

Often bottom-load adapters and/or piping result in voids high in the piping or fittings that will entrap pockets of air that are part of the calibrated volume of the standard when the volumetric field standard is filled from the top (i.e., during calibration). A bleed line must be installed at the

highest point of this entrapped void to automatically allow air and vapor to escape from the calibrated volume of the standard when it is filled from the top.

A bleed line shall be used where needed to automatically eliminate air that is trapped in lines or fittings during filling (meter proving and prover calibration) of a volumetric field standard. The bleed line shall:

4.5.18.1 Be leak free, with minimal fittings, and have a smooth inner bore,

4.5.18.2 Be either rigid or flexible as long as it continually slopes upward so that no vapor, air, or liquid can be trapped in the line (flexible bleed lines shall have a braided stainless steel, or other protective covering to prevent damage),

4.5.18.3 Be without any in-line valves that could be used to restrict flow,

4.5.18.4 Be made of a corrosion resistant material with large enough bore to prevent clogs and rigid enough to minimize the possibility of crimping,

4.5.18.5 Be routed to a higher point on the body or neck to ensure air and vapor freely escape and the line is totally filled with product, and

4.5.18.6 Be securely attached, not interfere with normal operation, and not create any other safety hazard.

4.5.19 **Bleed Valves Not Allowed**

Bleed valves that require manual manipulation to vent trapped air to atmosphere are not allowed on any new construction following the publication of this standard.

NOTE: Historically, bleed valves have been used to manually eliminate trapped air during top filling of a volumetric field standard. These valves create safety and environmental hazards from possible product spills due to leakage or inadvertently opened valves. They also create a significant potential for error if they are not considered during calibration. Existing volumetric field standards should be modified to replace bleed valves with bleed lines anytime a major repair or modification of the prover is completed that would allow a fitting to be safely welded to the side of the prover.

4.5.20 **Vapor Recovery**

4.5.20.1 Tube Placement

The external vapor recovery tube, on provers so equipped, shall originate at the top of the neck below the reinforcement band and end at a convenient point to interface with the vapor recovery hose of the system under test. It must be positioned so that the normal flow of product during top fill does not potentially splash out the port resulting in an error in calibration or use.

4.5.20.2 Fittings

The vapor recovery tube interface shall have appropriate fittings for connecting with the vapor return fitting and valve.

4.5.20.3 Recovery tube size

The size of the vapor recovery tube shall be appropriate for the systems being tested with appropriately sized fittings.

4.5.20.4 Pressure relief valve

Provers with vapor recovery provisions shall be equipped with a pressure relief fitting with a 20 kPa to 35 kPa (3 psi to 5 psi) rating. This pressure relief fitting is typically on the lid of the volumetric field standard.

4.5.20.5 Vacuum relief valve

Provers with vapor recovery provisions shall be equipped with protection against excessive vacuum during unloading. This fitting shall have vacuum relief rated at a maximum of 20 kPa (3 psi). This vacuum relief fitting is typically on the lid of the volumetric field standard.

4.5.20.6 Emergency venting

Provers used for flammable or combustible products shall be equipped with emergency venting to relieve excess pressure caused by exposure of the prover to fire.

4.5.21 **Hardware**

4.5.21.1 Handles

A hand-held test measure shall be equipped with a bail handle and shall hang with its axis vertical when filled with liquid and suspended from the center of the handle. The center of the bail handle shall be notched or bent into an inverted “V” to ensure accurate use and stability when hanging. The bail handle shall be attached by strong trunnions to the neck rather than to the cone to minimize any possibility of distortion of the measure when it is suspended while full of liquid. The ends of the bail handle shall extend through the trunnions and bend up or be otherwise secured so that the handle will not come loose during use, regardless of test measure position.

4.5.21.2 Trunnions

The trunnions used to attach the handle to the neck of the measure must be strong, durable, and securely attached to the neck of the measure.

NOTE: A filled test measure is very heavy with a sharp bottom rim that presents a significant safety hazard if the trunnions fail or come detached from the measure. It is incumbent on the manufacturer to ensure the durability and security of the design. The user should routinely inspect the trunnions for wear or signs of detachment and have the measure repaired if needed. Steel toed safety shoes are strongly recommended when using hand held volumetric field standards.

4.5.21.3 Plumbing

Any plumbing needed for filling or discharge of the prover shall not interfere with calibration. Prover drain systems shall disconnect for gravity drain during calibration and for observation of the cessation of flow. Exceptions are allowed for a prover system with permanent plumbing that has a return pump with a three-way valve (or a system of valves) connected to the pump line and to the gravity line. The valve (valve system) must allow water to be discharged through the gravity line without flowing through the pump. In the case of a system of valves, the main valve that determines the nominal capacity must be placed closest to the lower neck in the discharge line and must be equipped with a sight flow indicator (see also section 4.5.13 [Sight flow indicator](#)).

4.5.22 Volumetric Field Standard Leveling

4.5.22.1 Establishment of level condition

A volumetric field standard shall be leveled by placing a precision spirit or electronic digital level vertically against the neck on at least two locations, 90 degrees apart around the circumference of the neck and adjusting the orientation of the standard until the neck is as close to vertical (plumb or perpendicular to the horizontal plane) as possible.

This method of determining the level condition (*plumbing the neck*) shall be used for the replacement and adjustment of levels on all mounted volumetric field standards.

NOTE: Due to the variability in the mounting of the glass level vials, spirit levels are not always accurate. A simple test for a vertical (plumb) level is to place the level on a nearly vertical surface, note the reading of the bubble in relation to the lines on the vial and then flip the level around 180 degrees (left to right) on the same surface. The position of the bubble in relation to the lines on the vial (the reading) should be the same. The same test can be applied for the horizontal level by placing it on a nearly level horizontal surface and turning it 180 degrees (left to right). In either case, if the positions of the spirit level bubble relative to the lines on the vial do not agree, the level should be replaced.

4.5.22.2 Test measures

Hand held volumetric field standards (test measures) shall be level within applicable tolerances whether leveled at the neck, suspended by the bail handle, or placed on a level surface as determined by a precision spirit or electronic digital level.

4.5.22.3 Provers

All mounted volumetric field standards (provers), including those permanently mounted, shall have adequate provision for leveling. A truck or trailer on which a prover is mounted shall be equipped with at least three leveling jacks to maintain a level and stable condition when under full liquid load.

4.5.22.4 Leveling jacks

All leveling jacks shall operate freely and be stable under load. The load rating for leveling jacks should be determined on the basis of 125 % of the anticipated maximum load including the heaviest product to be tested.

4.5.23 Levels

4.5.23.1 Position

All mounted bottom-drain volumetric field standards (provers) shall be equipped with two, non-spring loaded, adjustable spirit levels mounted horizontally at right angles to each other, one approximately parallel to the surface of the scale plate, on the upper cone or where best visible from a standing position. Each level shall be mounted on a sturdy shelf and be equipped with a protective cover. The adjusting and mounting screws shall have provisions for sealing.

4.5.23.2 Level sensitivity

Spirit levels must have adequate sensitivity such that the level bubble will move by at least 0.1 in when the prover is out of level in the orientation of the vertical plane passing through the center of the sight glass and the center of the neck cylinder (i.e., commonly referred to as “front to

back”) enough to cause an error of 25 % of the volumetric field standard tolerance (0.0125 % of the nominal volume).

NOTE: Commercially available spirit levels with a specification of 0.1 in bubble offset per 45 min tilt or better meet this sensitivity requirement.

4.5.23.3 Bulls eye bubble levels

On 200 L (50 gal) or smaller volumetric field standards, a precision "bull's-eye" spirit level is permitted in lieu of two spirit levels, if the level has sufficient sensitivity to ensure proper reading of the liquid level in the standard. Each level shall be mounted on a sturdy shelf either near the base of the sight glass or on the rim of upper cone, directly in front of the sight gauge assembly.

NOTE: Commercially available precision "bull's-eye" spirit levels with a specification of 0.1 in bubble offset per 45 min tilt or better meet this sensitivity requirement.

4.5.23.4 Adjustment

Spirit levels shall be adjusted to as close to center as possible and sealed in position when the volumetric field standard is level based on plumbing the neck (described in section 4.5.22). Levels permanently attached to a volumetric field standard must be verified each time the standard is calibrated.

4.5.23.5 Auxiliary levels

Vehicle or trailer mounted volumetric field standards (provers) may have auxiliary levels mounted at a lower plane for operator convenience in adjusting leveling jacks. The primary levels on the prover (described above) shall be the reference levels for final leveling of the volumetric field standard. The primary levels should be used to set auxiliary levels. Auxiliary levels are only to be used for coarse leveling.

4.6 Workmanship, Finish, and Appearance

4.6.1 Finished Quality

A volumetric field standard, together with its associated valves, piping, gauge, etc., shall be free of slag, scale, weld or solder splatter, grit, dirt, dents, interior rust, water or product residue, or any other foreign matter before shipment from the factory or before submission for calibration.

4.6.1.1 Metal joints

All seams, whether welded or soldered, shall be filled and smooth to provide a continuous surface to prevent the entrapment of air or liquid, and shall not leak.

NOTE: During the calibration process, the metrologist should evaluate joints of field standards for leaks, particularly at neck and cone interfaces.

4.6.1.2 Neck cover

The neck of all vehicle mounted provers shall be equipped with a cover to prevent contamination or damage during transportation. The cover may be a vapor-tight hinged type, or if on large size provers, a pressure activated fill (PAF) manhole cover as used on tank trucks.

NOTE: All [pressure](#) and [vacuum](#) relief valve requirements shall be met.

4.6.1.3 Pipe caps

The ends of all permanently mounted fill, drain, product return, and vapor recovery pipes on a truck or trailer mounted prover shall be supplied with removable caps on mounted male fittings of like size to secure and cap pipes when not in use.

4.6.1.4 Required assembly

All parts of the gauge assembly, and all piping and valves affecting the volume of a field standard, shall be fully assembled by the manufacturer or supplier.

4.6.1.5 Thread connector lubricant

All threaded connections, including plugs and caps, shall be thoroughly lubricated with a suitable non-hardening paste, or pipe joint tape, and shall not leak. Connections and lubricants must be impervious to product used in the prover.

4.6.2 Coatings

4.6.2.1 Exterior coatings

The exterior surface of volumetric field standards made of low carbon steel shall be properly primed and coated with a glossy finish (white or a color which is reflective and prevents any unnecessary heating of the product within the prover) and that is impervious to the liquids for which the standard is used.

4.6.2.2 Internal coatings

The interior surface of standards made of low carbon steel shall be corrosion resistant or coated with a suitable material that is impervious to the liquids for which the standard is used.

4.6.2.3 Coating for edible commodities

If a standard is to be used for measurements of edible products, such as water or milk, governmental regulations regarding materials and surface finish shall apply.

4.6.3 Ladders and Platforms

Ladders and work platforms (with appropriate safety hand rails), when required, shall be secure and designed to support the operator while reading or servicing the neck-gauge assembly. The ladder shall be so constructed that there is no distortion of the prover when the ladder is in use. Ladder rungs should be constructed of a non-slip design/material.

4.7 Other Requirements

Evaluation of the following items is beyond the training and expertise of the typical laboratory metrologist. Each is covered by requirements and specifications of other organizations that supersede the requirements of this document. They are included for reference by manufacturers and as basic guidance to facilitate the detection of gross safety issues related to these systems. Calibration and evaluation of a volumetric field standard to the requirements of this handbook does not imply examination and approval of the items included in this section. These items are identified for informational purposes only.

4.7.1 Return Pump

The pump and piping shall be sized according to the prover volume and should be designed for use in petroleum service if applicable.

NOTE: Pumping rates must be balanced between convenience and deviation from total drain time differences between meter verification and gravity drain calibration. Different products flow through a pump at significantly different rates dependant on viscosity, lubricity, distance, head pressure, and many other factors. Therefore, it is rarely of any advantage to pump water from a volumetric field standard during calibration rather than use the normal gravity drain. Pump off times for water will be significantly different than those for petroleum or other products.

4.7.2 Grounding

A grounding lug or other mechanism is required on provers used for volatile liquids to protect against accidental discharge of static electricity. The lug shall be securely attached to the skirt of the prover and on the same side from which the prover is loaded to facilitate its regular use.

4.7.3 Wiring

All electrical connections on provers used for volatile flammable liquids must be explosion proof. All wiring, including low voltage wiring, shall meet the requirements of Article 300, 500, Group D, Class 1, Division 1, and 250.45 and/or other applicable articles of the latest edition of the National Electrical Code.

4.7.4 Electronic Overflow Systems

For safety reasons, most meter systems will not operate without a proper connection to a Factory Mutual Research (FM) approved electronic ground verification and overflow prevention system.

4.7.5 Braking System

The truck or trailer mounted volumetric field standard shall have an adequate braking system to handle the load and meet all Department of Transportation (DOT) requirements.

4.7.6 Labeling and Placarding

A volumetric field standard and any vehicle it is mounted on must be properly labeled and placarded according to DOT operational rules, National Fire Protection Association (NFPA) 58, and other regulatory requirements. Local laws and regulations vary between jurisdictions. It is incumbent upon the purchaser of a pressurized volumetric field standard prover to be aware of and comply with local laws and regulations regarding the transport of hazardous materials.

5. Tolerances (Maximum Permissible Errors)

5.1 Capacity Tolerance

For volumetric field standards (test measures and provers) the maximum permissible errors shall be ± 0.05 % of the nominal capacity.

5.2 Neck Tolerance

5.2.1 Neck Calibration Tolerance

The requirement in 5.1 Capacity Tolerances, also applies to the scale intervals marked on both sides of the scale mark corresponding to the nominal capacity of a volumetric field standard (test measure or prover). This means that the volume represented by each scale mark over the entire

range of the scale plate must be accurate within the maximum permissible error of 0.05 % of the nominal capacity.

5.2.2 Neck Uniformity Tolerance

The maximum capacity error between the nominal volume line and any other line on the scale shall be less than one (1) maximum subdivision as defined in Tables 2a and 2b. If smaller subdivisions are used, the maximum allowed subdivision is the tolerance applied to the neck uniformity. The application of this tolerance must allow for the uncertainty of the neck scale calibration measurement. Therefore, the neck scale capacity error must exceed the value of one division plus the uncertainty of the neck scale calibration in order to be rejected by the weights and measures enforcement agency.

5.3 Adjustment

Volumetric field standards (test measures and provers) should be adjusted during calibration to nominal values at the appropriate reference temperature whenever possible.

6. Verification Requirements

6.1 Legal Requirements

The specifications and tolerances specified in this handbook are intended to permit the use of the equipment in normal field testing operations as standards having nominal values. Weights and measures requirements, including but not limited to, inspection, testing, and sealing, by a laboratory Recognized by NIST Weights and Measures Division, or Accredited to ISO/IEC 17025 shall be followed.

NOTE: Some states or local jurisdictions have requirements that are not documented here. Check with the local jurisdiction for specific calibration and inspection requirements.

6.2 Traceability

Field standards used for legal metrology shall be traceable to national standards by calibration in a laboratory Recognized by NIST, or Accredited to ISO/IEC 17025, in that parameter, range, and scope. Check with the local jurisdiction for specific requirements.

6.3 Calibration Reports

Acceptable accuracy and traceability to national or international standards shall be documented in a calibration report using accepted test methods. A calibration report in compliance with the requirements of ISO/IEC 17025 must be prepared that states the calibration method used, the calibration medium (should be water), the temperature of the calibration medium at the time of test, the nominal volume of the prover, the reference temperature, the calibration error on the graduated neck if tested, the as-found and as-left calibration values, whether or not the prover has been adjusted, the expanded uncertainty (at a 95 % confidence interval) of the calibration, the prover serial number and date. Additionally, any exceptions or other information required to be identified by this standard must be included.

6.4 Initial and Periodic Verification

Field standards must be verified prior to use and rechecked as often as regulations or circumstances require, especially when damage is known or suspected, seals are broken or valves

in the measuring section are repaired or replaced. Test measure and prover calibration may be initially established at one year intervals and extended or reduced based on historical evidence up to the limit determined by state or local regulations, but should not exceed three years due to possible leaking valves or seals which are often difficult to detect under field conditions.

6.5 Calibration of Metering Devices

6.5.1 Using Volumetric Field Standards Without Application of Calibration Correction

Except for work of relatively high precision, it is recommended that the accuracy of standards used in testing commercial weighing and measuring equipment be established and maintained so that the use of corrections is not necessary. When the standard is used without correction (i.e., the nominal value is used as reference rather than the reported calibration volume), its combined error (difference between the calibrated volume and nominal volume) and uncertainty must be less than one-third of the applicable device tolerance.

NOTE: Volumetric prover measurement indications must be corrected for the temperature at the time of use from the calibrated volume determined using the reported reference temperature as described in section 4.2 Reference Temperature.

6.5.2 Using Volumetric Field Standards With Application of Calibration Correction

Device testing is complicated to some degree when corrections to standards are applied. When using a correction for a standard, the uncertainty associated with the corrected value must be less than one-third of the applicable device tolerance. The reason for this requirement is to give the device being tested as nearly as practicable the full benefit of its own tolerance.

NOTE: Volumetric prover measurement indications must be corrected for the temperature at the time of use from the calibrated volume determined using the reported reference temperature as described in section 4.2 Reference Temperature.

NOTE: Certain commercial volumetric meter test acceptance tolerances are of a relatively high level of precision. For these tests, it will often be necessary for the field inspector to apply the calibrated volume correction of the standard and a volumetric temperature correction to ensure the test accuracy is adequate for the meter tolerance applied. Failure to apply the calibration correction and temperature correction may result in invalid device approval or rejection.

7. Test Methods and References

Calibration of test measures or provers shall be by a documented nationally or internationally approved and recognized procedure. Hand held test measures require a 30 s (± 5 s) pour followed by a 10 s drain, with the measure held at a 10 degree to 15 degree angle from vertical, during calibration and use. Provers are emptied by gravity drain, followed by a 30 s final drain after the cessation of flow.

To ensure the safety of metrologists, improve the accuracy of calibration, and to prevent environmental contamination, all volumetric field standards must be free of petroleum, food, or chemical residue before calibration. Internal contamination may create environmental and safety issues and reduce calibration accuracy. External contamination creates fall and environmental

pollution hazards. If there is any evidence of leftover product or residual contamination, the volumetric field standard should be rejected until it can be safely cleaned in a way that is not detrimental to the environment.

7.1 **Calibration Methods**

Current reference methods are as follows:

7.1.1 **NIST IR 7383 Selected Volume Procedures, SOP 18**

Recommended Standard Operations Procedure for Calibration of Graduated Neck-Type Metal Volumetric Field Standards: Volumetric Transfer Method.

7.1.2 **NIST IR 7383 Selected Volume Procedures, SOP 19**

Recommended Standard Operations Procedure for Calibration of Large Neck-Type Metal Provers: Volumetric Method.

7.1.3 **NIST IR 7383 Selected Volume Procedures, SOP 14**

Gravimetric Calibration of Volumetric Ware Using an Electronic Balance.

7.1.4 **API, Manual of Petroleum Measurement Standards**

Chapter 4, Proving Systems, Section 9, Methods of Calibration for Displacement and Volumetric Tank Provers.

7.2 **Field Calibrations**

The responsibility for ensuring accuracy and traceability, with sufficiently small expanded uncertainties to meet the device testing requirements in NIST Handbook 44 is the responsibility of the local jurisdiction. A “field” calibration is considered one in which a calibration is conducted outdoors in uncontrolled environments by laboratory or field personnel. NIST recognizes laboratories for specific measurement parameters, ranges, and scopes (expanded uncertainties). Calibration conducted under field and laboratory conditions are not considered equivalent and require the maintenance and evaluation of separate control programs. The care required for field calibrations includes proper safety, clean and air-free water supply, measurement control programs, and a stable temperature-controlled environment shaded from direct sunshine to allow the prover, field standard, and test liquid (water) to reach an equilibrium temperature, with minimal evaporation. Environmental conditions should be controlled (or selected) to be as close to laboratory conditions as possible. All calibration data and appropriate environmental conditions must be documented regardless of test location.

8. **Uncertainties**

8.1 **Legal Applications**

Uncertainties of the calibration must be evaluated according to the ISO Guide to the Expression of Uncertainty in Measurement, 1993 to ensure that the three to one accuracy ratio requirement in NIST Handbook 44 is maintained. In 2009, the smallest acceptance tolerance for liquid measuring devices was 0.15 % of the measured volume for vehicle tank meters. Therefore, the expanded uncertainty for the calibration of a test measure or prover must be less than 0.05 % of the measured volume.

NOTE: Liquid measuring device tolerances should be evaluated at the time of use to ensure that suitable standards, tolerances for standards, and applications are used.

8.2 Sources of Variation

8.2.1 Accuracy

Accurate measurement demands the use of calibration equipment and standards with accuracy traceable to national or international standards and the use of standard procedures. Accurate and traceable measurements require the analysis of measurement uncertainty and an evaluation of that uncertainty to determine the adequacy for its intended use. In the case of field standards used in weights and measures applications, the expanded uncertainty for calibration must be less than 0.05 % of the measured volume. Further, the correction/error in the standard plus or minus the uncertainty must be less than the tolerance to ensure that if the prover is used without correction (within a suitably narrow range of variation around the reference temperature) the error will not impact the measurement result.

To achieve the required expanded uncertainty, the following estimates demonstrate the required standard uncertainties associated with major contributors in the calibration:

- laboratory standard(s): 0.01 % of the volume of the standard prover per delivery (at 95 % confidence interval);
- measurement process: 0.02 % of the volume of the prover under test;
- neck calibration: 0.05 % of the neck volume (note: the minimum neck volume is either 1.0 % or 1.5 % of total nominal volume) of the prover under test; and
- applicable tolerance: 0.05 % of the nominal volume for the prover under test when not adjusted to the nominal value.

When these factors are combined in a root-sum-square method and multiplied by a k-factor of two (95 % confidence interval), it provides an uncertainty of less than 0.05 % of the measured volume. If any one of the factors listed is greater than what is noted in the above list, the other factors must be reduced to compensate when one desires to maintain the required values for the expanded uncertainty (especially note the any uncorrected prover error!).

For the previous example, the values are combined as follows:

$$2 * \sqrt{(0.01/2)^2 + 0.02^2 + (0.05 * 0.015)^2} + |Prover Error| \leq Tolerance (\pm 0.05\%)$$

To achieve the necessary accuracy, the corrected volume depends on:

- use of proper temperature corrections;
- the uncertainty associated with the cubical coefficient of thermal expansion;
- the accuracy of temperature measurements.

Through proper use of documented laboratory and field procedures, additional uncertainty factors may be minimized to a level that does not contribute significantly to the previously described factors. Additional standard uncertainties in the calibration of field standards and their use in meter verification may include:

- how the prover level is established;

- how delivery and drain times are determined;
- the use of a proper “wet down” prior to calibration or use;
- whether gravity drain is used during calibration (as prescribed) or whether the volume of water is eliminated by pumping;
- differences in drain between calibration and use;
- the cleanliness of the prover and calibration medium;
- prover retention characteristics related to inside surface, contamination or corrosion, total drain times, and differences in liquid viscosities;
- possible air entrapment in the water; and
- the ability to properly read the meniscus.

Proper reading of the meniscus must be followed to prevent additional error in the calibration and use (see NIST IR 7383 Selected Volume Procedures, Good Measurement Practice 3).

8.2.2 **Repeatability**

Fifteen is the maximum recommended number of deliveries from a laboratory standard to a prover under test to minimize calibration uncertainties to the levels previously identified. Volumetric values obtained during repeated runs of a single calibration must agree to within 0.02 % of the test volume.

Repeatability problems may be due to poor prover design, a leak in the valves or seals of the prover, contamination or lack of cleanliness, improper cone slope, rust inside the volumetric field standard, and/or poor field conditions such as when calibration is conducted in unstable environments. Repeatability problems must be corrected before calibration can be completed.

Table 1a. Dimensional requirements for metric volumetric field standards

Size (L)	Minimum Metal Thickness * (in)	Maximum Upper Neck ID ** (in)	Gauge Tube ID (in)	Minimum Top Cone Pitch	Minimum Bottom Cone Pitch	Drain Size Min / Max (in)
5	0.0312	2.25	0.5	35°	---	--- / ---
10	0.0312	3	0.5	35°	20°	1.5 / 2.25
20	0.0312	4	0.5	35°	20°	1.5 / 2.25
50	0.0312	5	0.5	35°	20°	1.5 / 2.25
100	0.109	5	0.625	25°	20°	1.5 / 2.25
200	0.109	7	0.625	25°	20°	2 / 3
500	0.109	10	0.625	25°	20°	2 / 3
1 000	0.109	17	0.625	25°	20°	2 / 3
2 000	0.141	17	0.625	25°	20°	3 / 4.5
3 000	0.172	20	0.625	25°	20°	4 / 6
3 800	0.172	20	0.625	25°	20°	4 / 6
5 000	0.172	20	0.625	25°	20°	4 / 6

* Thicknesses are intended to be nominal. Materials used in the United States are available in “gauge” and inches. Actual thickness of sheet metal stock will vary slightly. For example, 12 gauge (U.S. Standard Gauge, 1893) has a nominal thickness of 0.1094 in but ranges from 0.0981 in to 0.1140 in.

**Neck diameter may vary; the critical factors to be considered which affect neck diameter are the volume above and below nominal, the graduation sizes, the minimum space between graduations and the use of fill pipes and vapor recovery systems.

For a capacity intermediate between two capacities listed above, the sizes prescribed for the lower capacity shall be applied.

Other than cone pitch and drain sizes, these specifications also apply to hand-held test measures.

NOTE: ID = inside diameter.

Table 1b. Dimensional requirement for U.S. customary volumetric field standards

Size (gal)	Minimum Metal Thickness * (in)	Maximum Upper Neck ID ** (in)	Gauge Tube ID (in)	Minimum Top Cone Pitch	Minimum Bottom Cone Pitch	Drain Size Min / Max (inches)
1	0.0312	2.25	0.5	35°	--	--- / ---
5	0.0312	3	0.5	35°	20°	1.5 / 2.25
10	0.0312	4	0.5	35°	20°	1.5 / 2.25
25	0.109	5	0.625	25°	20°	1.5 / 2.25
50	0.109	5	0.625	25°	20°	1.5 / 2.25
100	0.109	7	0.625	25°	20°	2 / 3
200	0.109	10	0.625	25°	20°	2 / 3
500	0.141	17	0.625	25°	20°	3 / 4.5
750	0.172	17	0.625	25°	20°	3 / 4.5
1 000	0.172	20	0.625	25°	20°	4 / 6
1 500	0.172	20	0.625	25°	20°	4 / 6

* Thicknesses are intended to be nominal. Materials used in the United States are available in “gauge” and inches. Actual thickness of sheet metal stock will vary slightly. For example, 12 gauge (U.S. Standard Gauge, 1893) has a nominal thickness of 0.1094 in but ranges from 0.0981 in to 0.1140 in.

** Neck diameter may vary; the critical factors to be considered which affect neck diameter are the volume above and below zero, the graduation sizes, the minimum space between graduations and the use of fill pipes and vapor recovery systems.

For a capacity intermediate between two capacities listed above, the sizes prescribed for the lower capacity shall be applied.

Other than cone pitch and drain sizes, these specifications also apply to hand-held volumetric field standards (test measures).

NOTE: ID = inside diameter.

Table 2a. Tolerances and scale plate volumes for metric field standards and provers

Capacity (L)	Tolerance (mL) (± 0.05 %)	Scale Plate		
		Minimum Total Neck Volume on Scale* (mL)	Maximum Value of Major Division** (mL)	Maximum Value of Subdivisions (Neck Uniformity Tolerance) (mL)
5	2.5	75 mL	25	5
10	5	150 mL	25	5
20	10	300 mL	50	10
50	25	750 mL	100	25
100	50	1.5 L	100	25
200	100	3.0 L	200	50
500	250	7.5 L	500	100
1 000	500	15 L	1 000	250
2 000	1 000	30 L	1 000	500
3 000	1 500	45 L	2 000	500
3 800	1 900	38 L	2 000	500
5 000	2 500	50 L	2 000	500

* “Total neck volume” is defined as the volume contained in the neck between the bottom-most scale graduation and the top-most scale graduation.” If increased readability of range or increased sensitivity is desired, the length of the reading scale may be adjusted with proportional adjustment of neck diameter, provided vehicle/mounted height constraints are not exceeded. This note is for clarification and background on the criteria given and is not intended to be used for calculating volumes on an as-needed basis.

** The maximum value of a division is based on the maximum neck ID given in Table 1a. Smaller diameter necks allow for a smaller division size, which is encouraged as long as division resolution and readability specifications are met.

Table 2b. Tolerances and scale plate volumes for customary volumetric field standards

Capacity (gal)	Tolerance (gal) / (in ³) (± 0.05 %)	Scale Plate		
		Minimum Total Neck Volume on Scale* (gal) / (in ³)	Maximum Value of Major Division** (gal) / (in ³)	Maximum Value of Subdivisions (Neck Uniformity Tolerance) (gal) / (in ³)
1	0.0005 / 0.12	0.015 / 3.5	0.005 / 1	0.001 / 0.25
5	0.0025 / 0.58	0.075 / 17	0.005 / 1	0.002 / 0.5
10	0.0050 / 1.2	0.15 / 35	0.02 / 5	0.005 / 1
25	0.0125 / 2.9	0.38 / 88	0.05 / 10	0.01 / 2
50	0.025 / 5.8	0.75 / 173	0.05 / 10	0.01 / 2
100	0.050 / 12	1.5 / 347	0.1 / 25	0.02 / 5
200	0.10 / 23	3.0 / 693	0.2 / 50	0.05 / 10
500	0.25 / 58	7.5 / 1733	0.5 / 100	0.1 / 20
750	0.38 / 87	11 / 2610	0.5 / 100	0.1 / 20
1 000	0.50 / 116	10 / 2310	0.5 / 100	0.1 / 20
1 500	0.75 / 173	15 / 3465	0.5 / 100	0.1 / 20

* “Total neck volume” is defined as the volume contained in the neck between the bottom-most scale graduation and the top-most scale graduation.” If increased readability of range or increased sensitivity is desired, the length of the reading scale may be adjusted with proportional adjustment of neck diameter, provided height constraints are not exceeded. This note is for clarification and background on the criteria given and is not intended to be used for calculating volumes on an as-needed basis.

** The maximum value of a division is based on the maximum neck ID given in Table 1b. Smaller diameter necks allow for a smaller division size, which is encouraged as long as division resolution and readability specifications are met.

Appendix 1. Optional HB 105-3 Volumetric Field Standard Specifications Evaluation Form

Submitted by:	Date:	
	Test Number:	
	Metrologist:	
	Model Number:	
	Serial Number:	
	Seals intact:	Yes/No
Description:		

Instructions: Evaluate each item. Check either the approved or rejected box. If not applicable or allowed for a special application, draw a line through both boxes. Explain all rejections and special application exemptions in the comments section. File with calibration documentation.

	Requirement	HB 105-3 Ref.	Evaluation Tips	Appd	Rej
	Identification	4.3	Check individual requirements for overall approval		
1	Identification placement	4.3.1	Permanently marked, weather & liquid resistant, contrasting color to background?		
2	Nominal capacity	4.3.2.1	Nominal capacity as listed?		
3	Manufacturer information	4.3.2.2	Name and address?		
4	Model number	4.3.2.3			
5	Serial number and year	4.3.2.4	Year may be combined in serial number if clear.		
6	Material ID & cubical coefficient of expansion	4.3.2.5	Material identified? CCE marked on standard?		
7	Delivery and/or drain time	4.3.2.6	Marked?		
8	Reference temperature	PO or Cal Cert	Reference?		
9	Limitations on use	4.3.3	Note any limitations on use:		
10	Construction material	4.4	Stainless steel <input type="checkbox"/> or low-carbon steel <input type="checkbox"/>		
11	Body and shape	4.5.1, 4.5.2	Circular cross section in horizontal plane? No fillers, adjusting plugs or cavities? Shape ensures emptying, drainage; no air trapped?		
12	Top and bottom cones	4.5.3	Adequate pitch, anti-vortex fin, cone trough drain?		
13	Neck (top)	4.5.4	Uniform, reinforcement roll or band, attachment?		
	Neck (bottom)		Neck & fill pipe cross sectional area? Drain valve, accessibility?		
14	Sight glass	4.5.5	Glass, clear, unbroken, mounting, leak free?		
			Inside diameter and wall thickness?		
15	Scale plate construction	4.5.6	Location: secant, less than 6 mm from tube?		
			Mounting: secure, corrosion resistant, same metal?		
			Adjustment: stable, < 25 % smallest scale division?		
			Adequate provisions for sealing?		
16	Scale plate markings	4.5.7	Permanent and legible?		
			Nominal volume & proper unit abbreviations?		
			“To Contain” <input type="checkbox"/> or “To Deliver” <input type="checkbox"/> marked?		
			Nominal and zero lines?		
			Graduation spacing (≥ 1.6 mm) & width?		
	Bottom scale plate – zero line?				
17	Scale plate units	4.5.8	Primary _____ Secondary _____ Scale unit?		
			Lack of confusion?		

Requirement		HB 105-3 Ref.	Evaluation Tips	Appd	Rej
18	Scale plate graduations	4.5.9	Span? _____ % of nominal? _____ Acceptable for W&M use (nominal near center)?		
19	Support	4.5.10	Reinforced at leg attachment, reinforcing bands?		
20	Thermometer wells	4.5.11	Number of wells: Placement of wells, provision for probe calibration?		
21	Drain, piping, and valves	4.5.12	Discharge piping at least 5° slope? Fast acting full port valve (non-retroactive)?		
22	Sight flow indicator (non-retroactive)	4.5.13	Clear, no cracks, near drain valve?		
23	Minimization of vaporization or foaming	4.5.14	Description:		
24	Fill pipe	4.5.15	Required if larger than 20 L (5 gal) used for top fill. Appears to be within 10 cm – 15 cm (4 in – 6 in) of bottom cone?		
25	Bottom loading	4.5.16	Placement, leak free, diverter plate with vent?		
26	Air entrapment	4.5.17	Note any possible sources of air entrapment.		
27	Bleed line (non-retroactive)	4.5.18	Equipped with a bleed line? Leak free, unrestricted, protected?		
28	Bleed valves not allowed (non-retroactive)	4.5.19	Equipped with a bleed valve? (Should be replaced with bleed line if major repair is required.)		
29	Vapor recovery	4.5.20	Placement, pressure & vacuum relief valves?		
30	Hardware	4.5.21	Handles, trunnions, & plumbing?		
31	Leveling	4.5.22	Leveling jacks adequate, test measure hangs level?		
32	Levels	4.5.23	Adequate, protected, agree with plumb neck?		
	Workmanship, finish, and appearance	4.6	Check individual requirements for overall approval.		
33	Finished quality	4.6.1	Joints leak free and smooth, neck cover, pipe caps, pipe joints sealed?		
34	Coatings	4.6.2	No interior rust? Exterior paint in good condition?		
35	Ladders and platforms	4.6.3	Sturdy, safety rails, non-slip surfaces?		
	Other requirements	4.7	No Approval Implied – Note any gross problems.		
36	Electrical requirements	4.7.1-3	Adequate pump, ground lug, wiring intact.		
37	Electronic overflow system	4.7.4	Note if present.		
38	Braking system	4.7.5	Note if present.		
39	Labeling and placarding	4.7.6	Note if present.		
	Test methods	7	Examine in preparation for calibration.		
40	Cleanliness	7	No residue, clear sight glass(es), non-slippery.		

Requirement	HB 105-3 Ref.	Comments

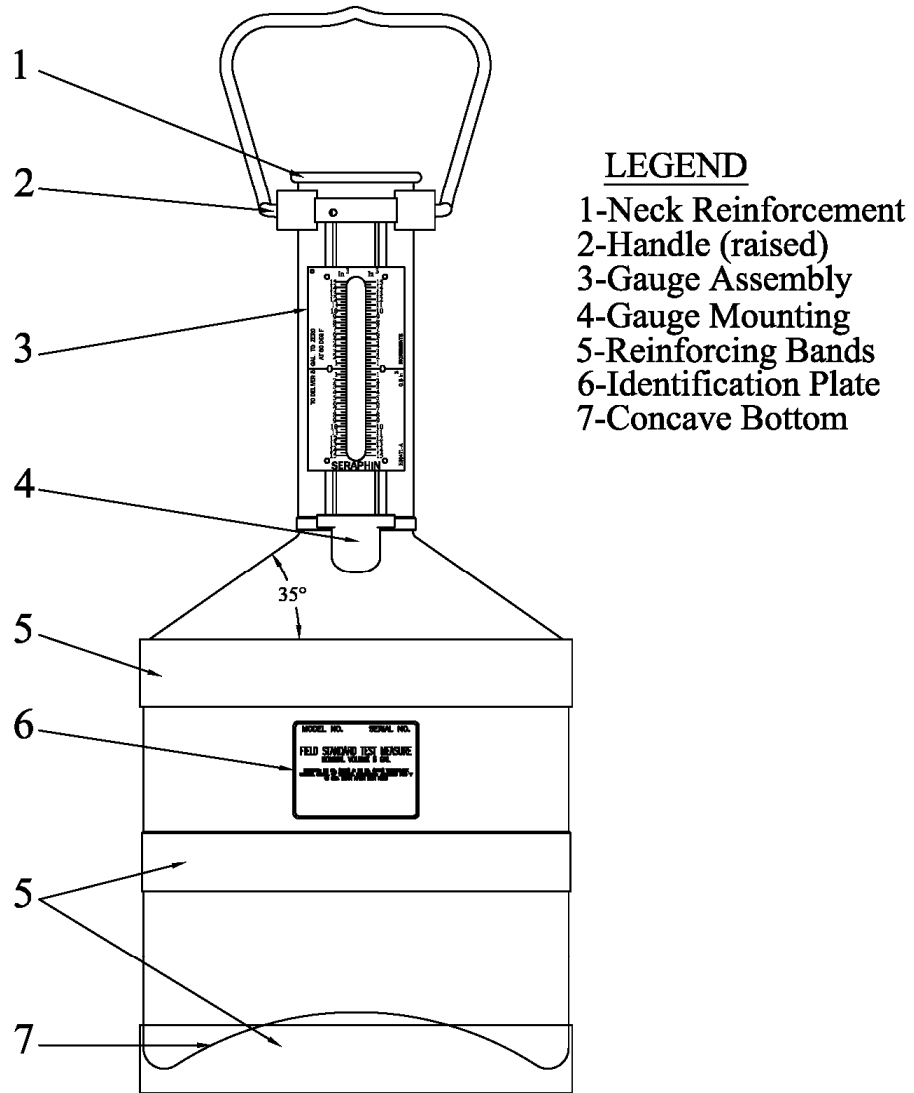

Figure 1. Hand-held volumetric field standard (test measure).

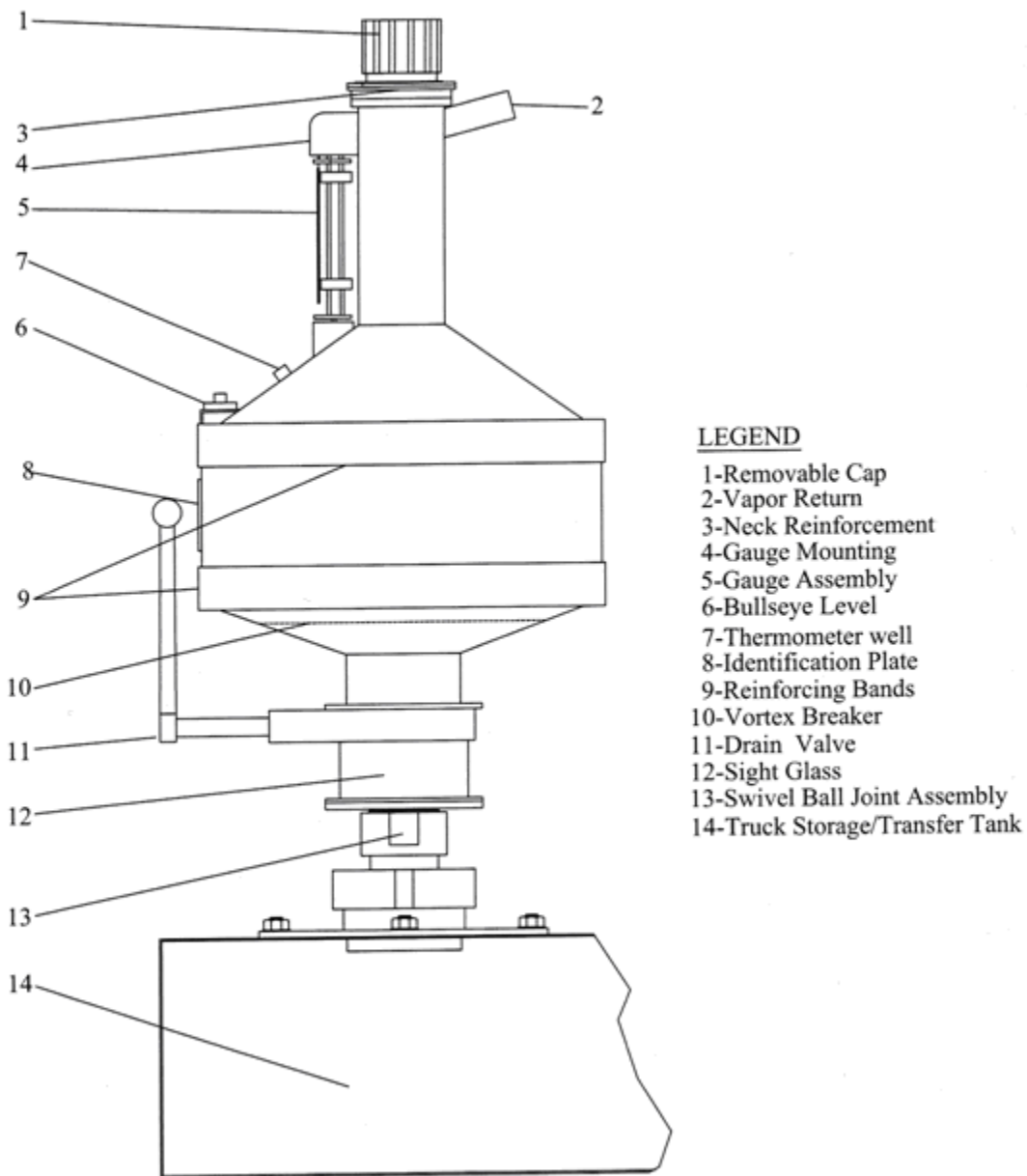

Figure 2. Small truck mounted volumetric field standard (prover).

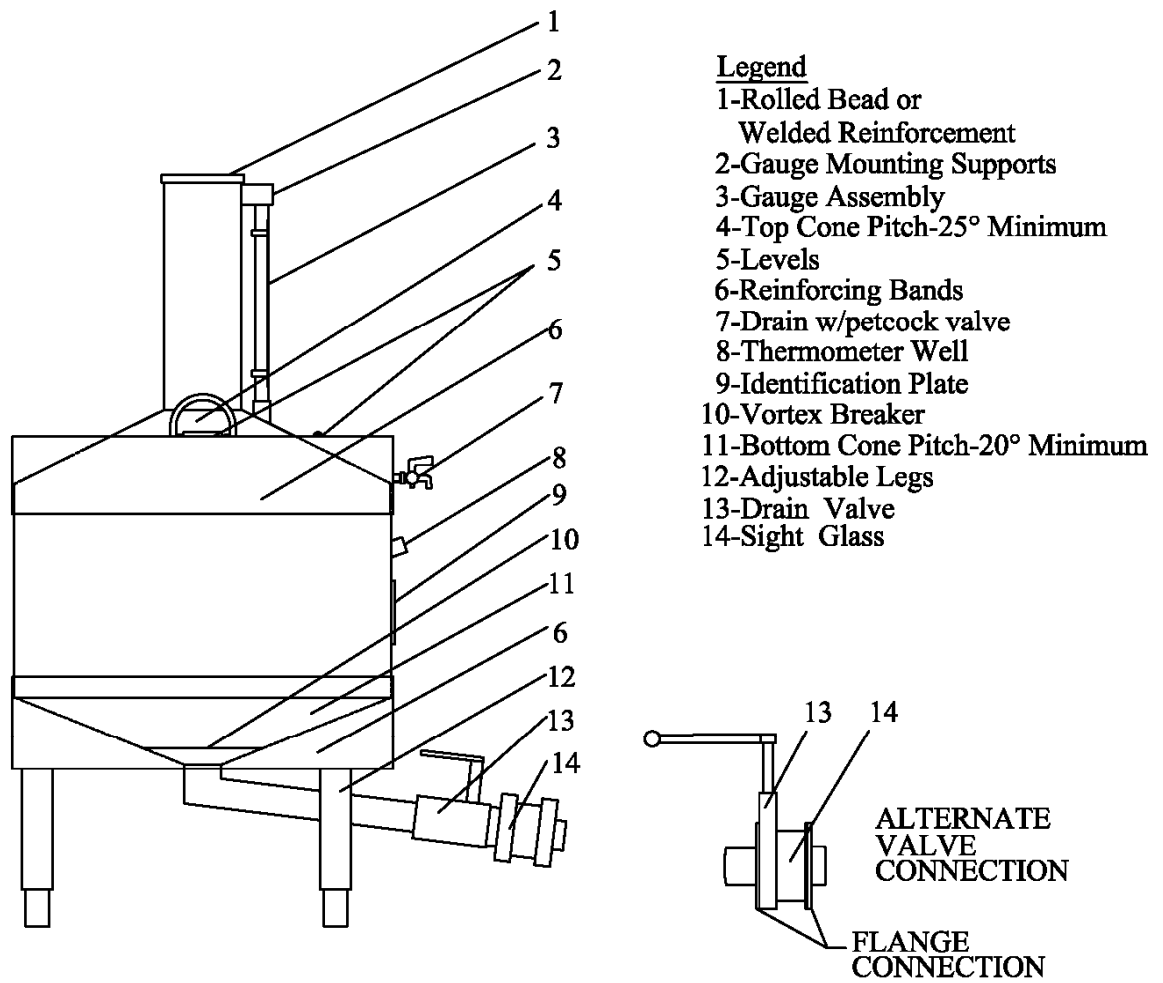

Figure 3. Mounted volumetric field standard (prover).

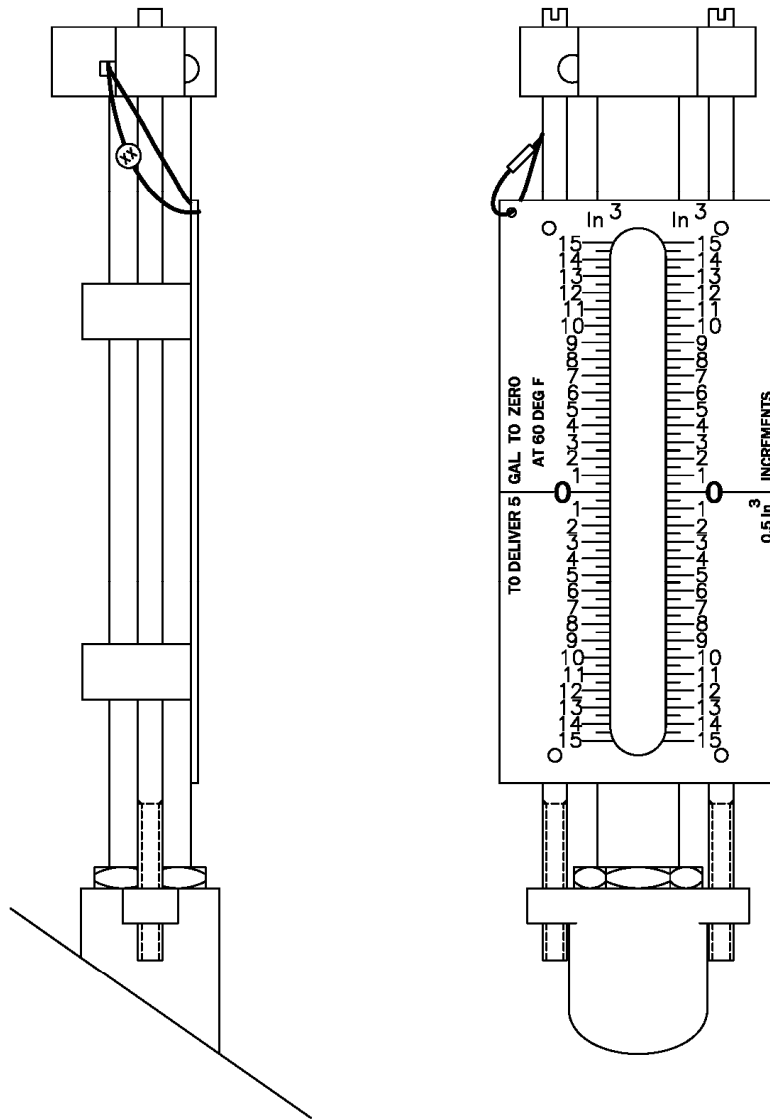

Figure 4. Sight gauge assembly.

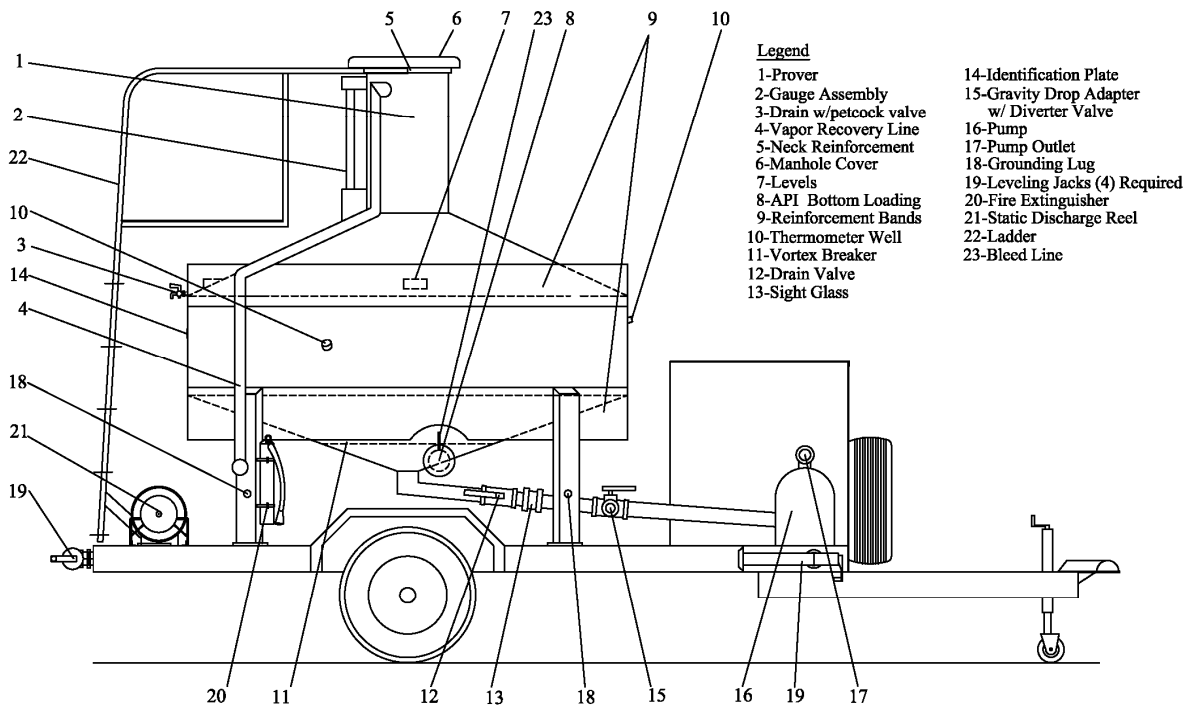

Figure 5. Trailer mounted volumetric field standard (prover).

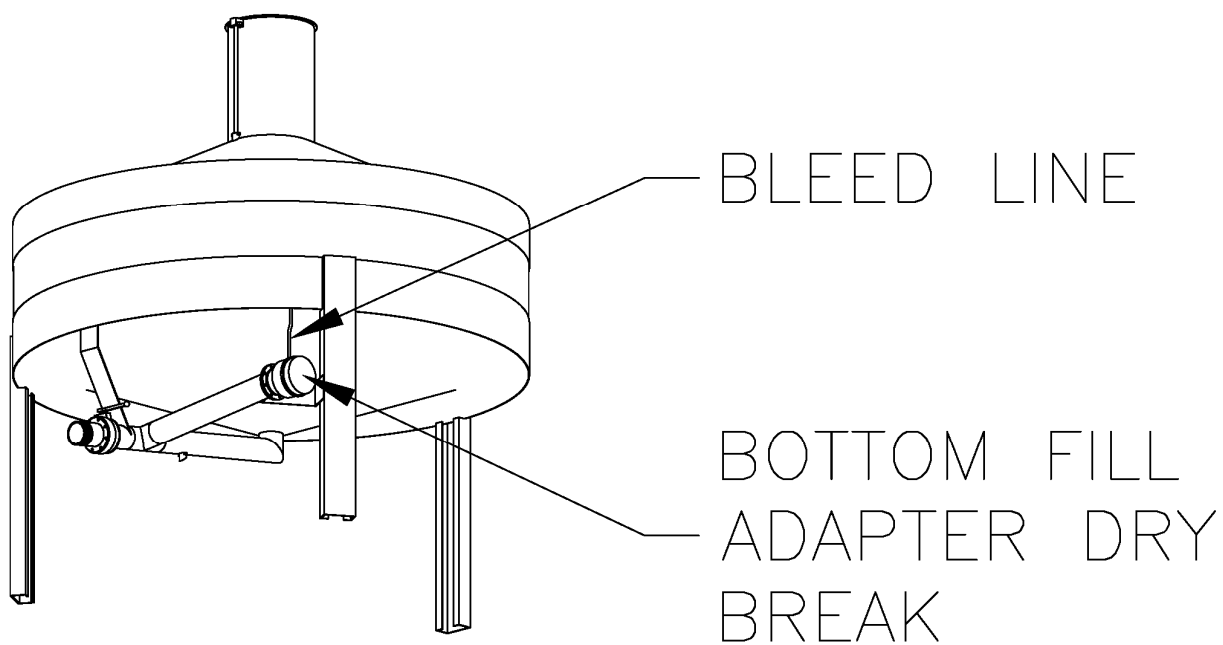

Figure 6a. Limiting vapor loss with fill attached to drain line.

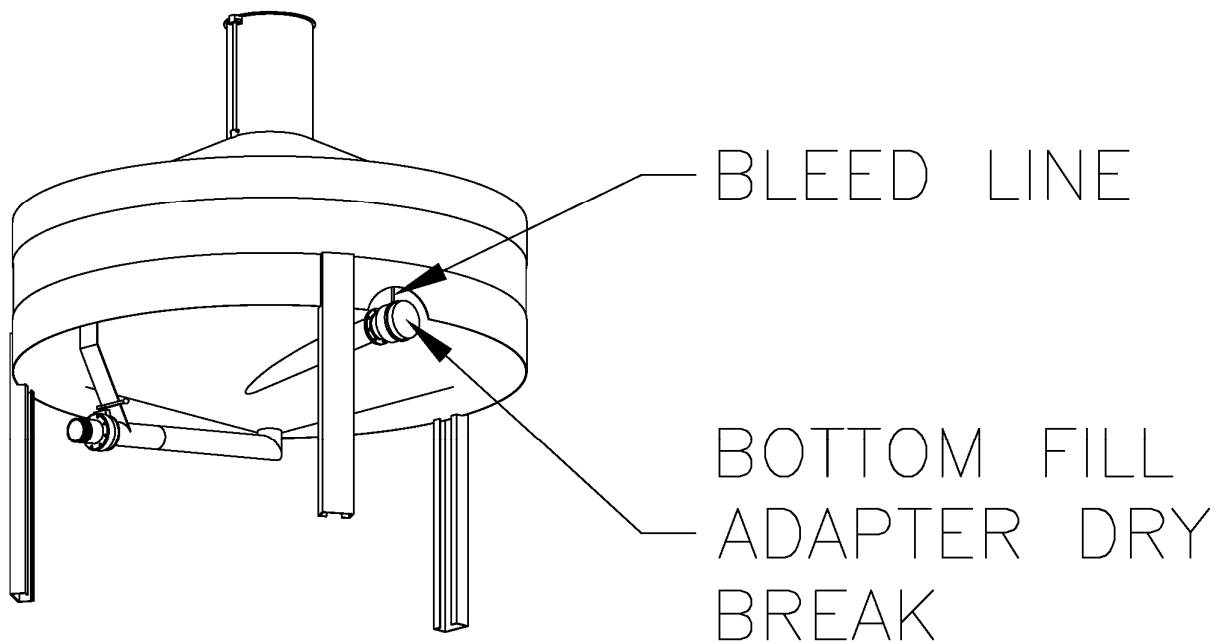

Figure 6b. Limiting vapor loss with fill entering bottom cone.

References

- ¹ American Petroleum Institute (API), 1220 L Street, NW, Washington, DC 20005-4070, USA. WEB Site: <http://www.api.org/>
- ² American Society for Testing and Materials (ASTM), 100 Barr Harbor Drive, West Conshohocken, Pennsylvania 19428-2951, USA. WEB Site: <http://www.astm.org/>
- ³ Factory Mutual Research (FM), 1301 Atwood Avenue, PO Box 7500, Johnston, RI 02919, USA. WEB Site: <http://www.fmglobal.com/default.aspx>
- ⁴ International Organization for Standardization (ISO), 1, ch. de la Voie-Creuse, Case postale 56, CH-1211 Geneva 20, Switzerland. WEB Site: <http://www.iso.org/>
- ⁵ National Fire Protection Association (NFPA), 1 Batterymarch Park, Quincy, Massachusetts 02169-7471, USA. WEB Site: <http://www.nfpa.org/>
- ⁶ National Institute of Standards and Technology (NIST), Weights and Measures Division (WMD), 100 Bureau Drive Stop 2600, Gaithersburg, MD 20899-2350, USA. WEB Site: <http://ts.nist.gov/WeightsAndMeasures/>
- ⁷ International Organization of Legal Metrology (Organisation Internationale de Métrologie Légale, OIML), 11, rue Turgot, F-75009 Paris, France. WEB Site: <http://www.oiml.org/>