

# The Dilemma of Surge Protection vs. Overvoltage Scenarios: Implications for Low-Voltage Surge-Protective Devices

**Arshad Mansoor**, Member, IEEE  
Power Electronics Applications Center  
Knoxville TN 37932 USA  
[Amansoor@epri-peac.com](mailto:Amansoor@epri-peac.com)

**François Martzloff**, Life Fellow, IEEE  
National Institute of Standards and Technology  
Gaithersburg MD 20899 USA  
[f.martzloff@ieee.org](mailto:f.martzloff@ieee.org)

© 1998 IEEE

Reprinted, with permission, from

*Proceedings, 8<sup>th</sup> Annual Conference on Harmonics and Quality of Power, Athens, October 1998*

Significance:

Part 2 Development of standards

Part 7 Mitigation techniques

The application of surge-protective devices (SPDs) in low-voltage AC power circuits, in particular metal-oxide varistors (MOVs) has been influenced by the perception that low-limiting voltage is a desirable characteristic. Unfortunately, this low limiting voltage – intended for surge protection – makes the devices more susceptible to fail under conditions of extended temporary overvoltage (TOV).

Like any electronic component, SPDs will fail if overstressed beyond reasonable limits, and this is not a cause for rejecting their application, but a cause for concern on ensuring that the failure mode – rare as it might be – will be acceptable.

This acceptability must also take into consideration the effect of the available fault current that the power system can deliver at the point of connection of the SPD. This point needs to be more clearly and specifically stated in emerging standards on SPD applications.

# The Dilemma of Surge Protection vs. Overvoltage Scenarios: Implications for Low-Voltage Surge-Protective Devices

Arshad Mansoor, Member, IEEE  
Power Electronics Applications Center  
Knoxville TN 37932 USA

François Martzloff, Fellow, IEEE  
National Institute of Standards and Technology\*  
Gaithersburg MD 20899 USA

**Abstract** - The application of surge-protective devices in low-voltage systems faces the dilemma of providing effective limiting against surges while not attempting to limit the temporary overvoltages that do occur in a power system. The paper illustrates this dilemma with specific scenarios and presents recommendations for reconciling these two conditions through adequate design and more explicit standards.

## I. INTRODUCTION

The concept of "Whole-House Surge Protection" has become a popular subject of discussion and has in fact been implemented by several utilities in North America. In this approach, the utility will install a surge-protective device (SPD) at the service entrance of the customer and provide additional plug-in SPDs. These additional SPDs are presumed to be well-coordinated with the service-entrance SPD, and are installed within the customer premises, presumably at the point of connection of so-called "sensitive appliances" such as home entertainment, computers, and sophisticated kitchen appliances.

The main purpose of these SPDs is to protect sensitive equipment against surges, a mission that they can accomplish quite well. However, the failure mode of these devices under temporary overvoltages (TOVs) that might be expected under abnormal but possible conditions of the power system has become cause of some concern for utilities and their customers.

An SPD should not be expected to protect downstream equipment in the case of a TOV and then return to normal operation, as it does by definition for surge protection. The dilemma for SPD designers is whether to select a maximum continuous operating voltage (MCOV) high enough to survive common TOVs — but at the price of diminished surge protection — or to select surge protection with a lower MCOV — and then accept failure of the SPD for infrequent but possible TOVs. In any case, one should expect that if a TOV at any level would cause the SPD to fail, that failure mode should be acceptable.

\* Electricity Division, Electronics and Electrical Engineering Laboratory, Technology Administration, U.S. Department of Commerce.

Contributions from the National Institute of Standards and Technology are not subject to U.S. copyright.

*Paper accepted for presentation at the 8<sup>th</sup> International Conference on Harmonics and Quality of Power ICHQP '98, jointly organized by IEEE/PES and NTUA, Athens, Greece, October 14-16, 1998*

0-7803-5105-3/98/\$ 10.00 © 1998 IEEE

This dilemma of surge protection versus overvoltage scenarios has been created by the industry's obsession with providing very low clamping voltages for surge mitigation (Martzloff & Leedy, 1989[1]). And now, the need to ensure coordination of the "cascade" of the service-entrance SPD and the plug-in SPDs has exacerbated this situation. The issue of cascade coordination has already been debated at length in the literature (Martzloff & Lai, 1991 [2]); (Stonely & Stringfellow, 1991 [3]); (Hostfet et al., 1992 [4]); (Rousseau & Perche, 1995 [5]). Further debate or exhaustive references to the many papers on that subject is not our purpose. It is mentioned here only as a contributing factor to the dilemma, but a factor that cannot be ignored in a complete assessment.

## II. SURGE PROTECTIVE DEVICES FOR LOW-VOLTAGE SYSTEMS

The introduction of metal-oxide varistors (MOVs) in the seventies was a timely innovation, concurrent with the increasing use of semiconductors in consumer products. While these semiconductors opened new opportunities, their relatively low tolerance for surges created a strong demand for better surge-protective devices. Unfortunately, market competition encouraged a downward "auction" that led to attributing high value to low clamping voltages, a situation unwittingly encouraged by the listing of "transient suppression levels" stipulated in UL Standard 1449 [6]. The list begins at 330 V for SPDs intended for 120 V circuits, although there is good evidence that most consumer loads do not need such a low level of protection (Anderson & Bowes, 1990 [7]); (Smith & Standler, 1992 [8]).

The generic structure of typical low-voltage residential power systems is shown in Figure 1 for the case of a detached home. Underground service has similar characteristics. This system extends from the outdoor line-side of the service drop all the way through the premises wiring, including plug-in type SPDs. Figure 1 also shows the various locations where an SPD can be installed.

Typically, there are six locations. The first three: ① at the outdoor weather-head, ② at the service entrance, and ③ on the line side of the main disconnect are within the scope of IEEE Std C62.34 [9]. The next three are within the scope of ongoing IEEE project P62.62 [10]: ④ at the load side of the panel disconnect, ⑤ at a permanently wired receptacle, and ⑥ as a plug-in device. Locations ③ through ⑥ are within the premises wiring and therefore under the control of the end-user, while locations ① and ② are under the control of the utility.

### III. FAILURE MODES UNDER SURGE CONDITIONS

For a correctly applied SPD, failure under surge conditions should be a very rare occurrence. Nevertheless, one can enumerate the following failure scenarios in a field application — including misapplications:

1. A single, large, and not anticipated impinging surge exceeds the capability of the SPD. An example of this situation can be the presence of switched capacitor banks;
2. A succession of surges, such as multiple lightning strokes, exceeds the capability of the SPD. This situation has been identified for distribution arresters (Darveniza, 1997 [13]) and might also occur for low-voltage SPDs;
3. A thermal runaway is launched in an SPD exposed to high ambient temperatures at the time when a surge (within specifications for normal ambient) occurs;
4. In the questionable scenario of an alleged “degraded” SPD (Stringfellow, 1992 [14]), a thermal runaway is launched by the heat generated during a within-specifications surge.

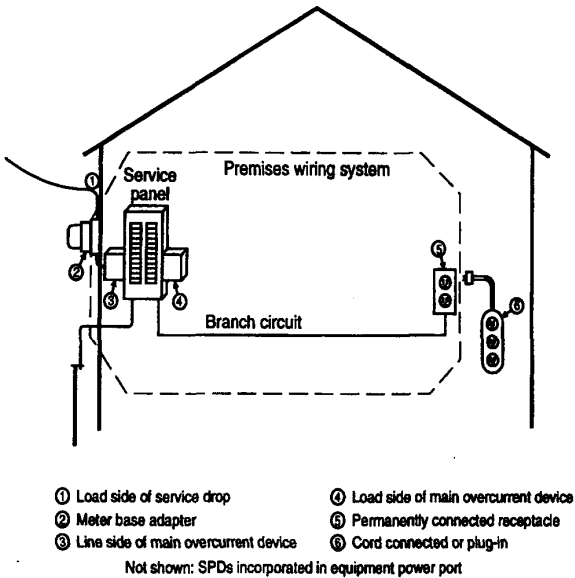

Figure 1 - Possible SPD locations for a residential building

An emerging requirement in standards for application of the low-voltage SPDs under development at the International Electrotechnical Commission (IEC 61643-1 [11]) as well as at the IEEE (P62.62 [10]) is the provision of a “disconnect” intended to disconnect a failing SPD. Failure under conditions exceeding the SPD capability is recognized as unavoidable, but the consequences of such failure are made acceptable thanks to the action of the disconnecter.

Unfortunately, some ambiguity has crept in the interpretation of this requirement. In some cases it has been interpreted as only disconnecting the failed SPD component from the power system, but leaving the load energized — and without further surge protection (Martzloff, 1998 [12]). If the disconnecter is of this latter type, the SPDs components of an SPD package will fail under TOV conditions, presumably in a safe manner, but then allow the TOV to be applied to the downstream load. This is undesirable for the typical user who values equipment protection above continuity of operation. Finally, there is the worst case, as reported in many anecdotal instances, where the failure mode of SPDs under TOV conditions has not been graceful, to say the least. These instances, while not very frequent, have led to new testing requirements for failure modes from the Underwriters Laboratories in the updated Second Edition of their UL 1449 [6] Standard for low-voltage surge-protective devices (“TVSS” in the industry jargon).

Given this unsettled situation, it will be useful to review the scenarios that can lead to failure of an SPD component in an SPD package, in particular under TOV conditions. For the sake of completeness, we will describe first some failure scenarios under surge conditions, as they have some bearing on the disconnecter design.

For all these scenarios, the ultimate failure mode depends on the fault current that the power system can deliver at the point of connection of the SPD. For moderate fault currents, such as on branch circuits, the disconnecter can generally provide protection. The fuse design can still be a challenge: carry the load current, carry the specified surge current, but melt in case of a power-frequency fault current resulting from failure of the SPD component. For very high available fault currents, such as that prevailing at some service entrances close to a large distribution transformer, successful clearing may be a greater challenge. Furthermore, coordination of overcurrent protection is more difficult, compared to branch circuits inside the building where the wiring impedance and the rating of circuit breakers in the panel can ensure proper coordination.

### IV. FAILURE MODES UNDER TOV CONDITIONS

Three major types of TOV-induced failures can be identified for low-voltage SPDs:

**Moderate TOVs** associated with power system faults, such as a line-to-earth fault in a three-phase system, creating a 1.73 times normal line voltage in the other phases. Ferroresonance can also produce moderate but significant overvoltages.

**Extreme TOVs** associated with the commingling scenario (accidental fall of conductors of a higher voltage upon conductors of a lesser voltage). No conventional, varistor-only SPD can be expected to survive such a scenario.

**Double voltage TOVs** associated with the loss of neutral in a single-phase, three-conductor, earthed center-tap system such as the 120/240 V service typical of North American systems.

Depending on the philosophy of the system designer, in particular the utility for the case of a service-entrance SPD, survival or expected but acceptable failure can be stipulated for the loss-of-neutral scenario.

**a) Moderate TOVs: System Faults**

Among abnormal conditions that can produce temporary overvoltages, we give two examples of incidents resulting in overvoltages not exceeding twice the normal voltage. Some SPDs based on the misconception that a very low clamping voltage is desirable might not survive such moderate TOVs.

**Single-phase faults to earth** on a three-phase system produce a shift in the unfaulted phases. The severity of the voltage rise depends on the fault location, the system impedance, and the earthing practices. For a TT power system in steady-state, the neutral will by symmetry be at the same potential as earth, as in Figure 2 (a). However, if an earth fault occurs on one phase, it will cause a shift of potential as the system attempts to maintain balance. The neutral will be elevated and a corresponding shift will be experienced by the other two phases. In the worst case of a completely isolated system with a bolted fault to earth on one of the phases, we could have the situation depicted in Figure 2 (b). This shows a neutral which has been elevated to one per unit, causing the unfaulted phases to drift up to 1.73 per unit with respect to earth.

For three-phase systems with an artificial neutral through an earthing transformer or a finite resistance, the earth impedance is high. This arrangement limits the fault current during a single-line-to-earth fault, but allows enough for fault detection using overcurrent relays. It also inserts some impedance between the system neutral and the actual earth so that the voltage on the unfaulted phases will shift toward somewhat less than line-line value as shown in Figure 2 (c).

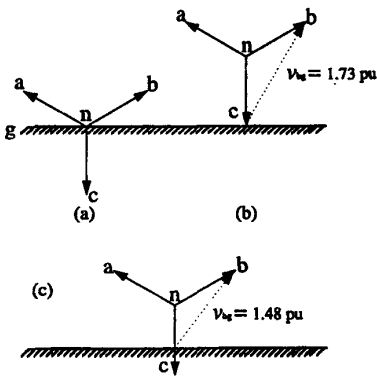
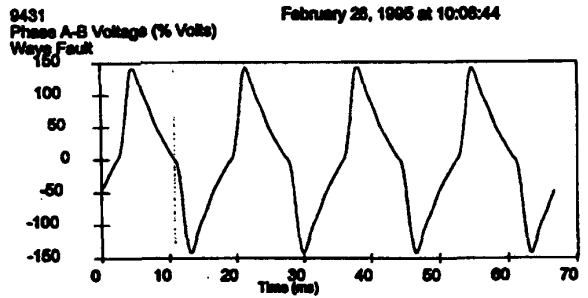

Figure 2 - Effect of a single phase-to-earth fault

**Series resonances** occur in a power system when a series circuit consisting of an inductance and a capacitance is excited at its natural frequency. As an example of this condition, Figure 3 shows a portion of a temporary overvoltage resulting from a power system switching incident (restoring power phase by phase after interruption [15]), which produced a sustained rms voltage exceeding 150% and lasting four seconds.



Source: EPRI Report [15]

Figure 3 - Temporary overvoltage caused by ferroresonance

**b) Extreme TOVs: Commingling**

In this real-life scenario, the low-voltage SPD connected on the secondary side of the distribution transformer, and normally energized at its rated voltage, is first brought to failure by the large overvoltage resulting from commingling conductors. In an overbuilt system, a collision of a vehicle with a pole, or breaks caused by icing, the conductors of the higher voltage distribution system or sub-transmission system can fall on the lower voltage distribution system. Such accidental contact injects an intruding voltage for a few cycles, until the higher voltage breaker clears the fault.

Figure 4 shows a simplified one-line diagram of the two medium-voltage systems (the intruding MV1 and the victim MV2) being accidentally commingled. In this figure, the bond between the two systems earth connections is shown in dotted line to present the generic case of commingling. In an overbuilt system with common neutrals, a solid bond exists where the dotted line is shown in the diagram. In the scenario of a simple crossing of two systems (not overbuilt along the right of way), or delta systems, a solid bond might not be present, and the fault current from MV1 will involve the earthing impedances shown in the diagram. In that case, the intruding voltage  $V_i$  might be less than the system voltage MV1 but still enough to precipitate failure of an SPD on the secondary.

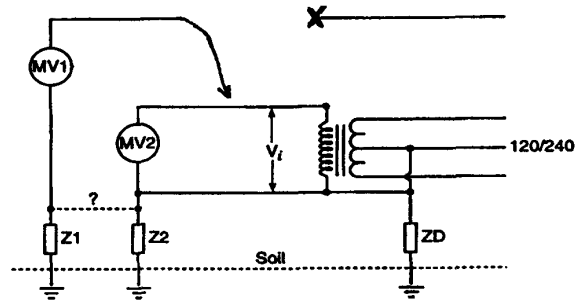

Figure 4 - Commingling overvoltage applied to the distribution transformer primary and reflected on the LV side

### c) Double-voltage TOV (Loss of neutral)

There are many situations where loss of neutral can occur. Some can be of a transient nature, such as a loose connection, while some might be permanent until repaired, such as a mechanical break or corrosion of the neutral conductor. While the latter might not linguistically fall under the label of 'temporary', the consequences are the same. In a three-wire, single-phase system typical of North American practice, this condition has been observed many times.

Figure 5 shows a system where one side of the supply (L1) is lightly loaded, while the other side (L2) is heavily loaded. Under normal conditions, the two sides remain at normal voltage. Should the neutral connection be lost, then the voltage at mid-point is determined by the ratio of impedances on the two sides: the L1 side experiences an overvoltage that can approach twice normal. Any SPD connected to this side will then be exposed to the twice-normal voltage, with an available current determined by the impedance Z2. This current, by the very design of the circuit, will not be interrupted by the overcurrent protection and is available to generate substantial heat in the SPD that has failed as the result of the overvoltage. A disconnecter designed to clear larger fault currents, such as those occurring if the SPD fails while the neutral is connected, might not be capable of clearing the limited current. Other schemes are then necessary to ensure an acceptable failure mode, such as a thermally-activated disconnect.

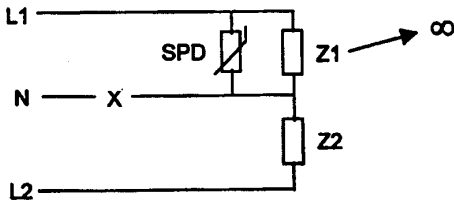

Figure 5 - Three-wire, single-phase system where a broken or intermittent neutral connection creates a voltage imbalance

## V. AVAILABLE FAULT CURRENT

As described in the preceding paragraphs, several scenarios can produce failure of the SPD, ultimately offering a very low (but not zero) impedance to the flow of the fault current that the power system can deliver. For each scenario, the available fault current at the point of connection of the SPD will have a very significant effect on the failure mode.

The significance of available fault current is recognized in standards, but the value that should be considered is generally left undefined. The following statements can be found in published standards.

*1996 National Electrical Code, 230-65, Available Short-Circuit Current*

*"Service equipment shall be suitable for the short-circuit current available at the supply terminals."*

*IEEE C62.34-1996, Standard for Performance of Low-Voltage Surge-Protective Devices (Secondary Arresters), Article 7.6*

*"If the manufacturer claims a fault current withstand rating, then that rating shall be verified."*

*IEC 61643-1 (FDIS November 1997) Surge protective devices connected to low-voltage power distribution systems - Part 1: Performance requirements and testing methods, Article 6.2.11*

*"The SPD shall be able to carry the power short-circuit current until it is interrupted either by the SPD itself, by an internal or external overcurrent disconnecter, or by the backup overcurrent protection."*

It is noteworthy that none of these documents specify a value for the available short circuit, but rather leave it to the discretion of the manufacturer, while imposing criteria of acceptability after the failure. The NEC tersely requires the device to be "suitable," without elaboration. The two standards applicable to a service-entrance SPD — where the available fault current can be quite high — acknowledge the possibility of failure and significance of the available fault current, but do not stipulate specific values.

In an attempt to obtain information on what levels of fault currents should be considered, an informal survey was conducted among a few utility engineers. It turns out that very few utilities limit the available fault current at the service point of residential customers but many people are under the misconception, as cited below, that all residential service load centers and breakers are limited to an available fault current of 10 kA and therefore they assume that actual available fault current must be less than 10 kA.

Interestingly, none of the individuals consulted on this issue could cite a standard or even a document with the status of a consensus guide that does stipulate a current value. Two perceptions seem to prevail among the individuals consulted, as quoted below:

- 1. Based on the observation that breakers for typical residential service panels (up to 200 A) generally have an interrupting capacity of 10 kA, it would be logical that the available fault current at the service entrance would be in the same order of magnitude.*
- 2. Based on the reality that a service entrance connected close to a large distribution transformer (such as a garden apartment or high-rise) will have available fault currents in excess of 10 kA, it would be prudent to review the specifics of the situation.*

Furthermore, these standards do not require that the SPD application data state a limit of acceptable fault current.

## VI. EMERGING STANDARDS

### a) SPDs installed downstream from the service entrance

In recognition of the issues raised by failure modes of the SPDs within the scope of UL Standard 1449 — downstream of the main disconnect — the second edition of this standard [6] now requires demonstration of an acceptable behavior in the failure mode of SPDs exposed to various overvoltage scenarios. Specifically, among the many tests required by UL, three tests address the issue:

**Temporary overvoltage with high available current** - This test is stipulated under article 37.2 of UL 1449, calling for extended exposure to 125% of normal line voltage with either an acceptable temperature equilibrium being attained or until an internal disconnect device operates. This test will demonstrate capability of sustaining moderate overvoltages, primarily providing a margin against high system voltage, but not the higher levels of temporary overvoltages covered in the next test. The available fault current specified for this test is defined as a function of the ampere rating of the service over a range of 200 A to 25 000 A.

**Full phase voltage with high available fault current** - This test is stipulated under article 37.3 of UL 1449, calling for exposure to the "full phase voltage" as shown on Figure 2(b) of this paper. The same criteria as above apply, namely acceptable temperature equilibrium or operation of an internal disconnect.

The available fault current specified for this test is defined as a function of the ampere rating of the service over a range of 200 A to 25 000 A.

**Overvoltage with limited current** - This test is stipulated under article 37.4 of UL 1449, with overvoltage values presumably corresponding to a loss of neutral scenario, and the associated low values of current supplied by the connected load, as in Figure 5.

It is noteworthy that in the stipulations of these three tests, the emotionally charged word "failure" is not used. Instead, a list of unacceptable conditions is given, including emission of flame, molten metal, flaming particles, charring of adjacent material, ignition of enclosure, or creation of openings leaving live parts accessible.

### b) SPDs installed upstream from the service entrance

For SPDs connected upstream from the service panel, the recently published IEEE Standard C62.34 does describes a loss-of-neutral scenario with limited current, similar to the UL 37.4 test. However, a demonstration test is not mandated, as the consensus development process settled for a weaker statement: "if the manufacturer claims a loss of neutral withstand capability ... then that capability shall be verified ..." Thus, the inference might be made that if no claim for loss-of-neutral withstand capability is made, no demonstration test is required. However, an additional paragraph in the standard does mention "...must fail in an acceptable manner."

From this brief overview of emerging standards, it appears that on the low side of available fault current, both the UL and the IEEE standards have recognized the issues of acceptable failure modes associated with temporary (or quasi-permanent) overvoltages. On the other hand, at the high side of available fault currents, it seems that insufficient recognition of the issue still prevails, as discussed in the preceding section on the significance of the level of available fault currents.

Nevertheless, Figure 6, offered as background information in a tutorial addressing considerations on the revenue meter environment (Ward, 1980 [16]), shows typical values of fault current as a function of distribution transformer size and length of service drop. That figure clearly shows values in excess of 10 kA, but somehow this information has not been fully recognized by the SPD community.

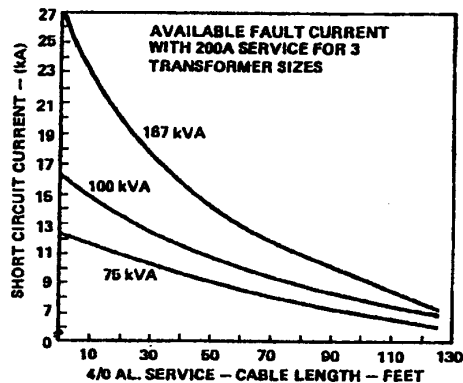

Source: (Ward, 1980 [16])

Figure 6 - Fault current amplitude as a function of transformer rating and length and size of service drop

## VII. POSSIBLE SOLUTIONS

Among possible solutions, two approaches may be considered: making the SPD less sensitive to TOVs, and, in any case, ensure that if failure is unavoidable under extreme stress, it will be in an acceptable mode.

The obvious way to desensitize SPDs to TOVs is to design them with a higher MCOV. However, as the higher MCOV in a varistor-only SPD means a higher surge-limiting voltage, there is a limit beyond which such an SPD becomes useless (op cit., [2-5]).

A possible solution may be in reviving the concept of a gapped arrester for the upstream SPD of a "whole house" scheme (Mansoor et al., 1998 [17]). There, the initial let-through associated with the gap volt-time response can easily be mitigated by the downstream SPD, while the gap prevents the SPD from becoming involved with moderate TOVs.

Of course, for the (rare) commingling scenario, little can be done but to ensure a graceful failure. This condition should be an implicit requirement, but, as discussed in the section on available fault current, the implications of such a requirement apparently have not been recognized by all interested parties. Even among the community of SPD engineers, there has been some reluctance to accept the concept that *temporary overvoltages* should be addressed in documents discussing the *surge* environment.

### VIII. CONCLUSIONS

1. The dilemma of providing a suitable surge protection of load equipment by means of surge-protective devices, while ensuring acceptable response of these surge-protective devices to unavoidable temporary overvoltages raises several application issues that demand attention.
2. "Acceptable response" can be interpreted either as survival of the SPD (a challenge to the coordination of cascades) or as accepting failure, but within well-defined conditions of the failure mode (a challenge for applications where high available fault currents prevail).
3. Coordinating a cascade of surge-protective devices can be solved by providing a gapped arrester at the service entrance, which will coordinate with the de facto situation of low limiting voltage SPDs inside the building.
4. The need for a service-entrance arrester to withstand the scenario of lost neutral can be satisfied by a gapped arrester having sufficient maximum continuous operating voltage capability.
5. Emerging standards for low-voltage SPDS have given new recognition to the importance of taking into consideration temporary overvoltages in the design of SPDs.
6. Notwithstanding conclusion (5), SPD application standards as well as performance and test standards should be more explicit in defining how to deal with the issues raised by available fault current in case of unavoidable SPD failure.

### IX. REFERENCES

1. Martzloff, F.D. and Leedy, T.F., "Selecting Varistor Clamping Voltage: Lower Is Not Better!" *Proceedings, 1989 Zurich International EMC Symposium*.
2. Martzloff, F.D. and Lai, J.S., "Cascading Surge-Protective Devices: Coordination versus the IEC 664 Staircase," *Proceedings, PQA 91 Conference*.
3. Stringfellow, M.F. and Stonely, B.T., "Coordination of Surge Suppressors in Low-Voltage AC Power Circuits," *Proceedings, Forum on Surge Protection Application, NISTIR-4657, August 1991*.
4. Hostfett, O.T., Hervland, T., Nansen, B. and Huse, J., "Coordination of surge-protective devices in power supply systems: Needs for secondary protection," *Proceedings, International Conference on Lightning Protection, Berlin, September 1992*.

5. Rousseau, A. and Perche, T., "Coordination of Surge Arresters in the Low-Voltage Field," *Proceedings, 7th International Telecommunications Conference (INTELEC), 95CH35824*.
6. UL 1449 *Standard for Safety for Transient Voltage Surge Suppressors*, Second Edition, August 1996.
7. Anderson, L.M. and Bowes, K.B., "The Effects of Power-Line Disturbances on Consumer Electronic Equipment," *IEEE Transactions PWRD-5, No.2, April 1990*.
8. Smith, S.B. and Standler, R.B., "The Effects of Surges on Electronic Appliances," *IEEE Transactions PWRD-7, No.3, July 1992*.
9. IEEE Std C62.34, *IEEE Standard for Performance of Low-Voltage Surge Protective Devices (Secondary Arresters)*, 1996.
10. IEEE Project P62.62 - *Application Guide - Low-Voltage Surge-Protective Devices* (ongoing).
11. IEC Document 37A/63/FDIS -Draft IEC 61643-1: Surge-protective devices connected to low-voltage distribution systems Part 1: Performance requirements and testing methods, November 1997.
12. Martzloff, F.D., "Interpretation and Misinterpretation of TVSS Disconnect Indications," Scheduled for publication in *Power Quality Magazine*, July/ August 1998.
13. Darveniza, M., Tumma, L.R., Richter, B., and Roby, D.A., "Multiple Lightning Currents and Metal-Oxide Arresters," *IEEE Transactions PWRD-12, No.3, July 1997*.
14. Stringfellow, M.F., "Fire Hazard of Surge Suppressors," *Proceedings, Fifth Annual Power Quality Conference*, Irvine CA, 1992.
15. EPRI Report *An Assessment of Distribution System Power Quality*, Electric Power Research Institute, Palo Alto CA, 1996.
16. Ward, D.J., "Secondary Fault Currents at the Service Entrance," *Proceedings, 55th Annual Electric Meter School and Conference*, University of Florida, Gainesville FL, 1980.
17. Mansoor, A., Martzloff, F.D., and Phipps, K.O., "Gapped Arresters Revisited: A Solution to Cascade Coordination" *Paper PE-114-PWRD-0-12-1997*, IEEE Winter Power Meeting, 1998.



**Arshad Mansoor (M' 1995)** is an Electrical Systems Engineer at the EPRI Power Electronics Applications Center (PEAC). He received his MS and Ph.D. in electrical engineering from the University of Texas, Austin in 1992 and 1994 respectively. His areas of interest include Power Quality, power systems transients analysis, harmonics, surge propagation and protection, and EMTP model development.



**François Martzloff (M'1956, F'1983)** Born and educated in France, with additional MS degrees from Georgia Tech and Union College, worked at General Electric for 29 years and now 13 years at the National Institute of Standards and Technology. He is contributing to several technical committees for the development of standards on EMC, surge protection and Power Quality in the IEEE and the IEC.