



Robocup Rescue Robot League Competition
Awardee Paper
Padova, Italy, July 2003

TEAM: IUTMicrobot
COUNTRY: Iran
AWARD: 3rd Place

Hamid Mirmohammad Sadeghi (sadegi_m@cc.iut.ac.ir)
 Hamed Bastani (hamed@ecerc.org)
 Ehsan Azarnasab (ehsan@ecerc.org)

Electrical & Computer Engineering Research Center,
 Isfahan University of Technology,
 84156, Isfahan, Iran.

Tel: +98-311 3912480
 Fax: +98-311 3912481

<http://www.ecerc.org/iutmicrobot>

Abstract— IUTMicrobot has focused its researches on Rescue Robots chiefly for 2 years. The goal was implementing robots, to make search and rescue action easier and safer in real condition. The idea was implementing two robots, one fast and small; to catch a global view of disaster and prepare a path sketch, another one slow but with complete set of equipments; to get victims and environment details.

NIST test bed provided in RobocupRescue 2003 was a good opportunity to test robots in semi-realistic settings, and learn more from other participants. Refer to our lab tests; we guessed we would have no problem with software, electronic design, algorithm, even mechanics. The ability of our Robots in remotely detecting victims, using none-touch accurate sensors, perfect & user friendly interface, and generating map outside the disaster arena, are main advantages for successful search and rescue actions. Different parts of Robots; sensors, hardware & software, are presented. Then the Robot control scheme, mapping method, and user interface is introduced. Also, this paper addresses the problem of mobile robot localization in urban environment.

Index Terms— Disaster building, IUTMicrobot, Localization & mapping, Rescue robot, Victim.

1 TEAM INTRODUCTION

There is nothing as beautiful as creating. A creature can see, hear, talk, write, move, think, and decide. A Robot!

IUTMicrobot team was formed 1999. The major activities are in Robotics field. It is more than 2 years affiliated by ECERC (Electrical & Computer Engineering Research Center) of IUT (Isfahan University of Technology).

It was the first experience that we participated in Robocup Rescue, and we got 3rd place in Rescue Robot League Competition. It was not the only award during our robotics activities; we got 1st place in RoboDeminer Contest 2002 which held by United Nations with the goal of "Looking for peace and safety", and 2nd place in Intelligent Mice 2001, Iran. We participated in RobocupRescue 2003, Padova, Italy, with two Robots work cooperatively. One is called ECERC1 (Fig.4) and is equipped with needed sensors to detect and locate victims using their vital signs, and chemical characteristics (described in part 4). The second Robot called ECERC2 (Fig.5), is smaller and faster than the other. It is used to catch a global view of disaster and prepare a path sketch .It is just equipped with a wireless color pan video camera.

Fig.2 shows the general block diagram of Robots and Operator Station.

ECERC1 has a Pan/Tilt (2 DoF) Set (PTS) on it, as Victims Identification Sensors Unit (VISU). It consists of a none-touch infrared thermometer, wireless color pin-hole video camera, ultra sonic range-finder, AGC microphone and speaker, and laser-pointer. There are some sensors to read situation of PTS (Angles for feedback). PTS can change it's situation in spherical coordination $((r,\theta,\varphi)$ while $r = cte$ related to Robot), and centralize on victim, remotely, with out touching . Based on coordination related to start-point of arena (x_0, y_0, z_0) in Cartesian system, operator station processor (PCU) can



Robocup Rescue Robot League Competition Awardee Paper Padova, Italy, July 2003

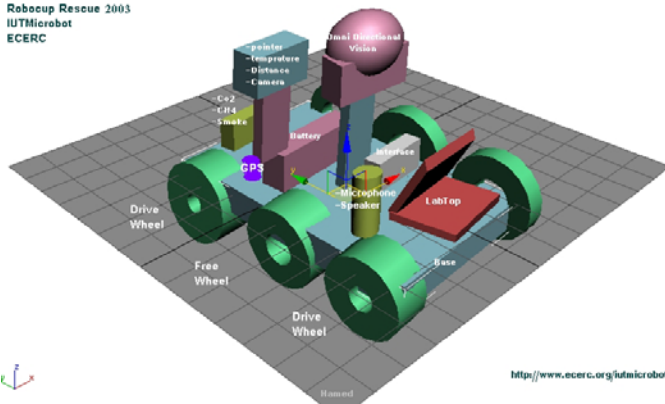

Fig. 1: ECERC1 Aspect Ratio.

calculate the remote-victim's situation. PCU in both Robot and operator side is a laptop.

Additionally, a smoke-Detector and a CH₄ sensor provided on robot to report the air conditions of the disaster (not used in NIST test bed Robocup Rescue 2003).

RNU of ECERC1 uses a front webcam for a straight vision, an analog wireless color video camera (on PTS), and also an Omni directional digital camera (for a global view of arena).

The ECERC1 communicates with operator station using a 2.4 GHz WLAN for data, and 1.2 GHz for video.

Fig.3 shows ECERC1's parts relationship.

ECERC2 uses a pan wireless color video camera as RNU, VISU and RLU. It communicates on 56 MHz for data and 1.2GHz for video.

Operator side's PCU uses on-line video and data received from Robot-Side, and prepares them for controlling, monitoring, saving and/or printing by operator's selection. Operator can remotely check either Robot's behavior or correct any mistake, to accomplish the search action. Finally he/she can edit the computer-generated map and send it to a printer.

In Rescue settings, issues such as operator fatigue, lack of situational awareness of the operator, cognitive load on the operator, and the number of individuals on operator can control in real time, all place limitations on human control [1]. To decrease these limitations in real disaster arena, not only an autonomous Robot with complicated AI core is needed, but also an operator is inevitable for critical decisions.

We plan to accomplish our systems autonomy for next year, especially on map generation.

2 ROBOT LOCOMOTION

ECERC1 is a 4WD system with 2 freely moving wheels totally 6 wheels (Fig.1) and ECERC2 moves by independently driven side caterpillars, like a Tank. So, both Robots have Differential-Drive architecture for motion. In this method both Linear-velocity and Rotational-velocity are under control [2].

PCU on robot, decodes and translates received commands through RCU, then gives it to LDU. ECERC1 employs 4x12W

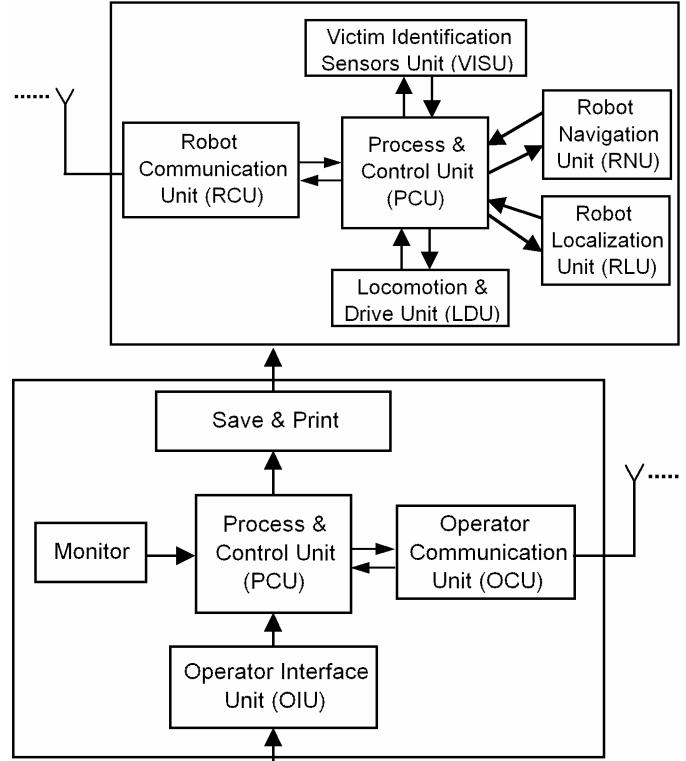

Fig. 2: Robot and Operator Station Block Diagrams.

DC motors for movement. The main part of motor drive circuit is L298 IC. Wheels are connected to motors through appropriate gear-boxes. For neutralizing spikes of motors, RC filters are used. This method protects communication instruments and processor unit against motor noise [8]. PTS also uses two low-power DC motors.

3 NAVIGATION & LOCALIZATION SENSORS

It is important to localize Robot related to a set point in arena, absolutely (while victim's position is read relatively to robot's coordination).

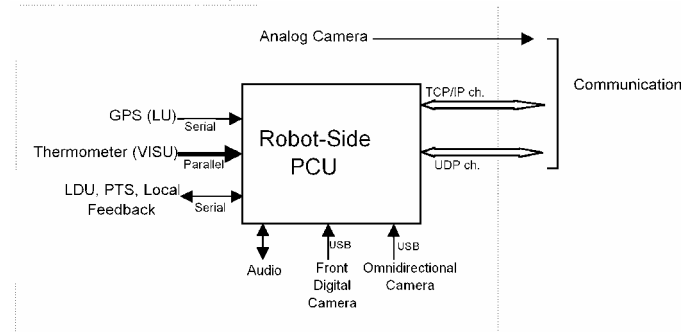

Fig. 3: Data Acquisition block diagram.



Fig. 4:ECERC1.

Operator navigates ECERC1 using an omni-directional digital camera, and ECERC2 by its rotary camera. A GPS is provided for automatic localization [9] of ECERC1. So that the software sets start point as a reference point for mapping and tracking. But we couldn't use GPS to localize and navigate the Robot, because of no satellite coverage in the test arenas in Robocup 2003. In real condition, there may not be enough signals for a GPS, to localize itself. So, GPS is not a good choice for real-rescue and it forces the operator to localize the Robot(s), visually, it reduces overall performance and waists rescue-time. However, we have to solve the localization problem using other odometry methods for future.

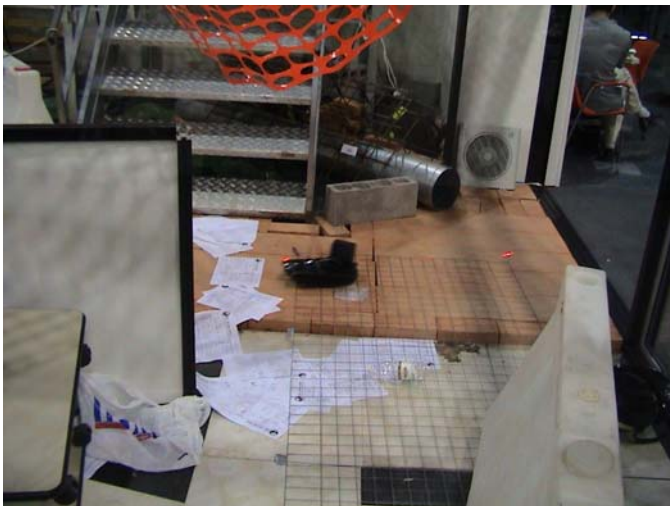

Fig. 5:ECERC2.

4 VICTIM IDENTIFICATION SENSORS

According to NIST standards for simulated victims [3], the Robot should detect victims from their vital signs. ECERC1 can measure victims' temperature using a Non-Touch Infra-

Red Thermometer. It also checks audible signals using an AGC microphone and sends them to operator station. Motion and body form of a victim is detected visually, while a laser points victim in video image. The distance between Robot and victim (r) is measured using an ultrasonic transceiver. All these sensors are provided in ECERC1 and placed on PTS. Robot can turns PTS and focuses on a far-victim (Fig.6 & 7) Sensors' outputs are normalized, coded, and packaged in a frame through interface circuits and microcontroller, on Robot. Then it prepares a packet to be sent to operator station, while classified headers & trailers are added to it for more security and safety. Packets are sent on-line, and cause online map generation (including victim's status & situation). So, if the robot goes out of work, operator knows Robot's current-position and victims scanned before.

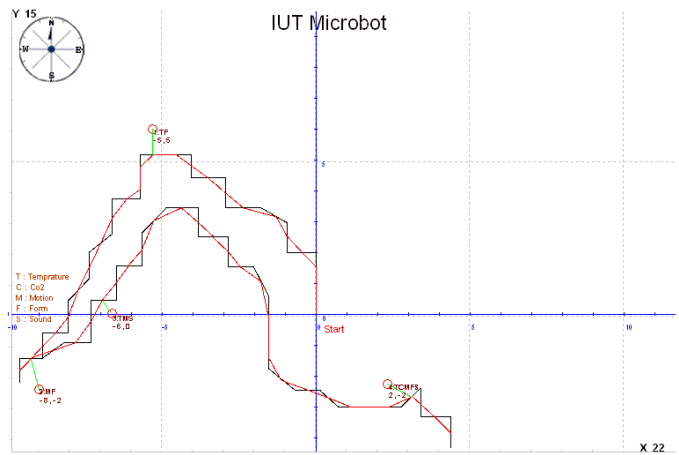

Fig. 6: Printable Map

5 MAPPING THE ENVIRONMENT

To have flexibility and reliability, mapping process is done in operator side and the map is saved automatically.

As Robot moves, GPS output changes. PCU compares current degree East and degree North with (E_0, N_0) as zero point, so, Robot location (R_x, R_y) is calculated. Robot motion path is achieved by connecting the calculated points (black lines in Fig.6). Smoothing the path (red lines in Fig.6) extracts a better approximation for Robot direction (N).

$$\begin{bmatrix} V_x \\ V_y \end{bmatrix} = \begin{bmatrix} R_x \\ R_y \end{bmatrix} + \begin{bmatrix} \cos \varphi & \sin \varphi \\ -\sin \varphi & \cos \varphi \end{bmatrix} \begin{bmatrix} N_x \\ N_y \end{bmatrix} \times r \cos \theta \tag{1}$$

$$N = \begin{bmatrix} N_x \\ N_y \end{bmatrix} = \text{Normalized Robot direction}$$

φ = PTS horizontal angle

θ = PTS vertical angle

r = distance between Robot & victim

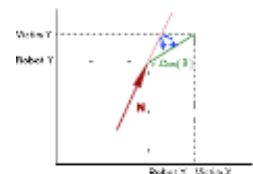

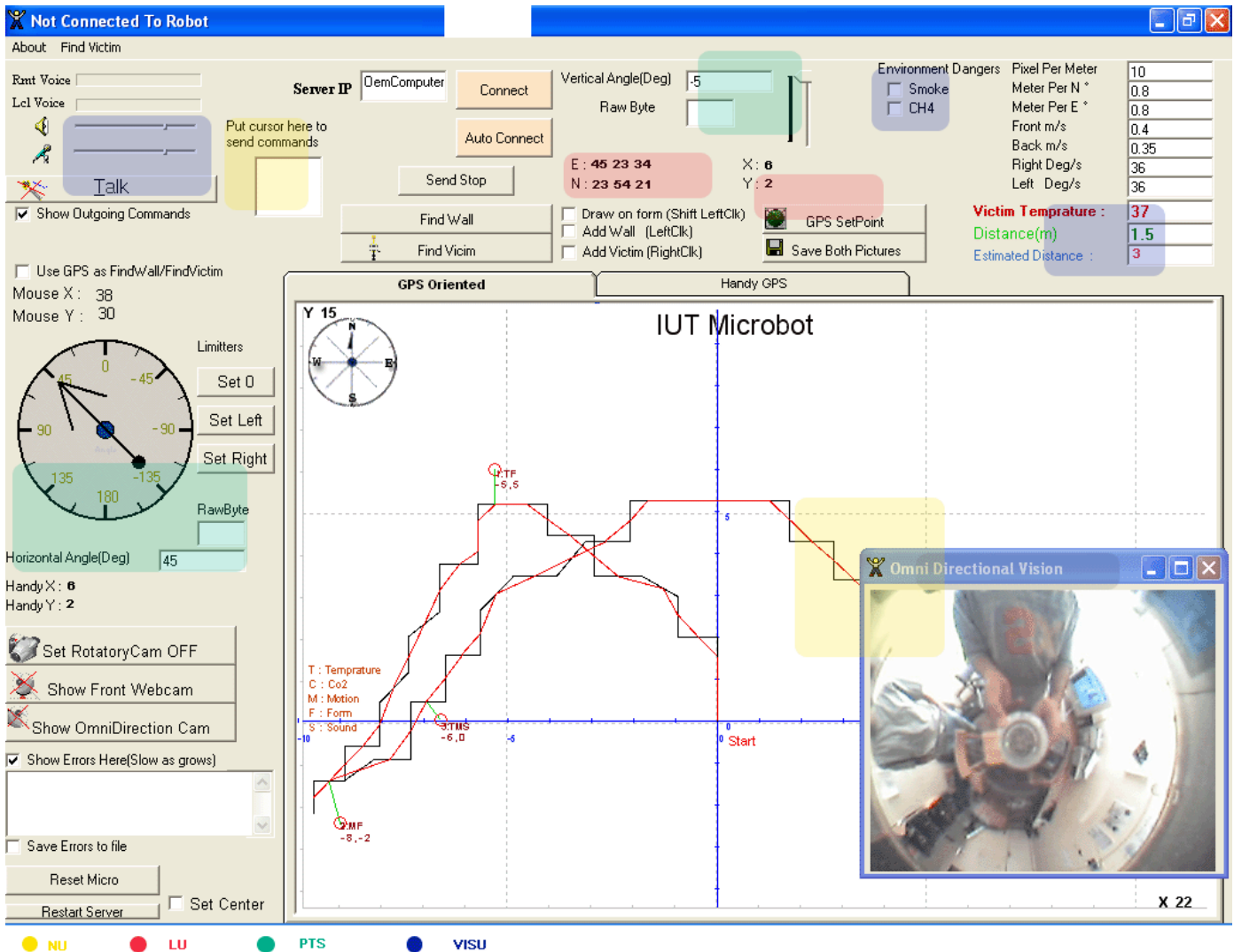

Fig. 8: GUI.

Using (R_x, R_y) and PTS report (r, θ, ϕ) , absolute position of victim is extracted (1). Victim specification abbreviations are also shown on map (red circles and green lines in Fig. 6). Geographical North is shown on the map by a compass.

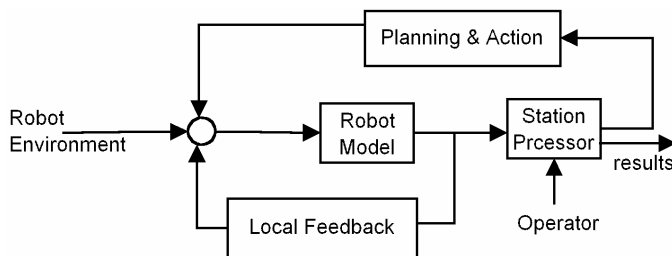

Fig. 9: Control Loop.

6 CONTROL SCHEME

Gathered data from arena and victims, are sent to operator side PCU. It checks them, localizes Robot, calculates victims' situation, tracks the Robot and draws the map. Operator can check the videos sent by Robot, and details shown by software interface. He/She can correct the path or map and even can drive Robot manually. So, ECERC1 is partially autonomous, while ECERC2 is tele-operated, i.e. a human being closes the general control loop.

ECERC1's actions (especially moving in disaster building), are generally based on received commands from operator station. If some problems disconnect Robot from station (e.g. radio interference), and/or hanging station's PCU, it opens control loop and makes Robot dangerous for arena and

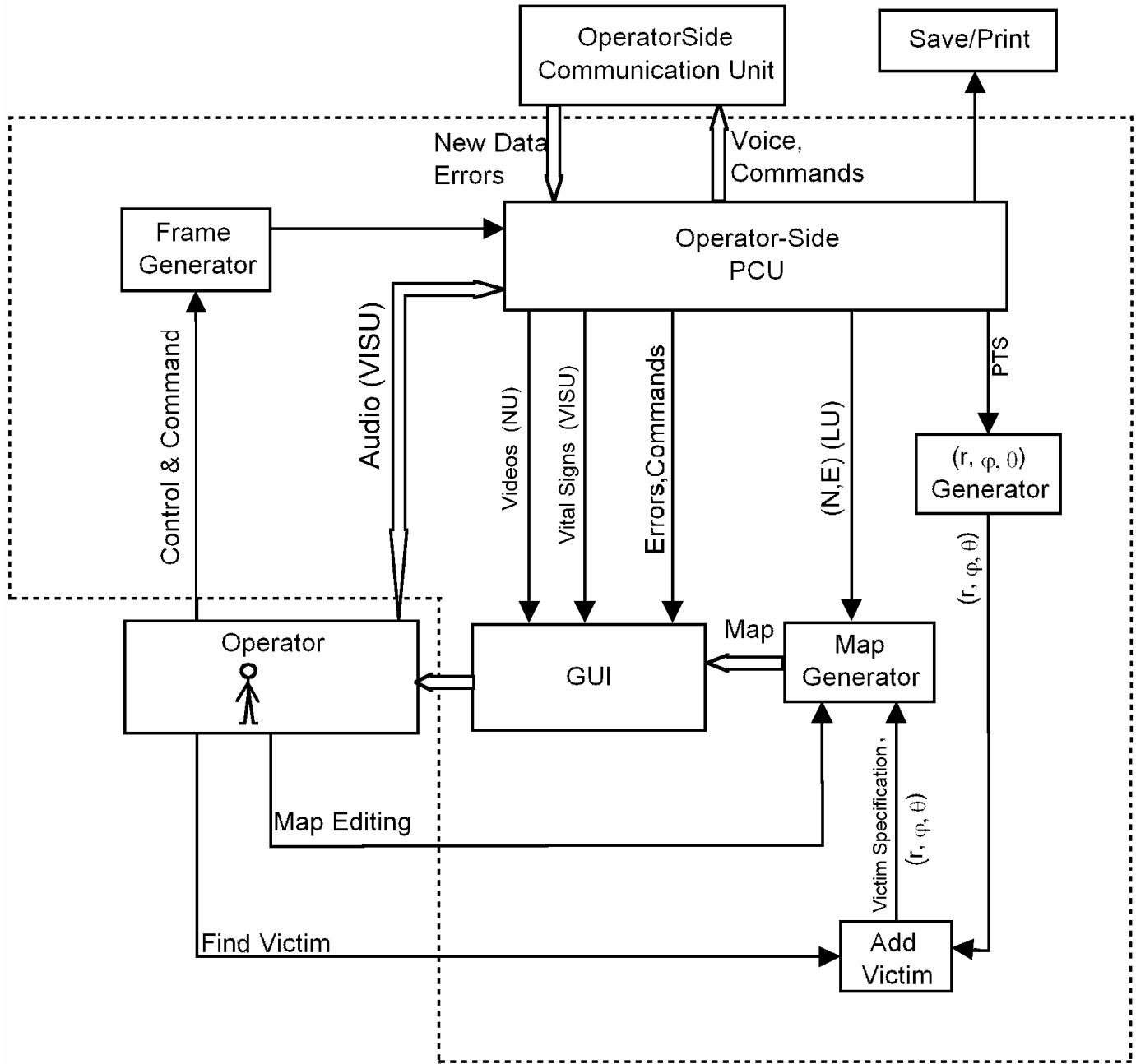

Fig. 10: Operator Station Flow Graph.

victims. Also, hanging Robots PCU may be hazard for environment, victims, even the Robot itself. So, a local controller is provided on Robot. It checks Robot's behavior, data flow, and local feedbacks (DC motors of Robot, Left & Right limits of PTS, etc.) . When Robot's RCU output or PCU is invalid, it disables all motion instruments on Robot. It is composed of 8255WD (with embedded watch dog), PAL, and some momentary elements. It is considered in Robot-

model and prepares a gently action. Fig.9 shows the close loop control flow graph.

7 OPERATOR STATION

Laptop's mouse, keyboard, monitor, headset and an additional TV are ECERC1's operator station parts. Flow graph of operator station is shown in Fig. 10.



Robocup Rescue Robot League Competition Awardee Paper Padova, Italy, July 2003

Operator uses Graphical User Interface (GUI) for monitoring the Robot and disaster area to control the Robot, finding victims and their status.

Temperature and audio channel help operator to find hidden victims. GUI & PCU software is implemented using Microsoft visual basic 6.0 and available components, considering HMI standards [4].

RLU, VISU, RNU and PTS outputs build a user friendly virtual panel on GUI (Fig.8).

External control commands (motion and restart) are framed and sent to Robot by communication unit. To keep the communication channel alive, Frame Generator creates “keep alive” command, when the channel is free. Operator can restart Robot control board, remotely.

8 COMMUNICATIONS

ECERC1 should communicate with operator station, outside the test arena or real disaster area, to send information or receive commands. So, a PCMCIA WLAN card is provided. It is compatible with IEEE 802.11 standard [10]. Digital videos (webcams' outputs) and audible signals are sent over UDP, while TCP is used for data/commands [5]. Analog video is transmitted by a video sender on 1.2 GHz.

ECERC2 communicates on 56 MHz for data/commands, and sends video on 1.2 GHz.

9 PERFORMANCE OBSERVATIONS

We believe our user interface is perfect and includes enough parameters to control the Robot. Robot's sensors for finding victims played their role, well, and we believe that the PTS provided on ECERC1, makes it more flexible and helps the Robot to distinct victims, remotely. Also using PCU-independent local-controller, we have provided on our Robot, made it safer for real rescue action. Another positive parameter is just an operator can check/control/correct more than one Robot's action. ECERC1 and ECERC2 work cooperatively, i.e. they can help / guide each other. Generating map outside the rescue arena can help the human-rescuers when the Robot system is out of work. Our team setup and breakdown time was proper, because of packaging our equipments; and this is essential for real rescue.

10 FUTURE DIRECTIONS

For a realistic use of Robots in search and rescue, we plan to improve mechanical structure of our Robot(s); to be more powerful and stable, complete sensor-set and make the Robot(s) closer to a full autonomous system. Localizing and navigating methods will be accomplished and it is better to have multi agent Robots.

ACKNOWLEDGMENT

Thank those who provided specific support for our research efforts, in Isfahan university of Technology (IUT), especially Electrical & Computer engineering Research Center (ECERC).

References

- [1] J. Casper., and R. Murphy, 2002. *Workflow on human-robot interaction in USAR*, in proceedings of the IEEE international conference on Robotics and Automation, volume 2, 1997-2003. Washington, DC: IEEE.
- [2] M. Davarpanah-Jazi, H. Bastani, E. Azarnasab and A. Shariatmadari, *IUTMicrobot RoboDeminer2002 paper*, proceedings of the 2002 International RoboDeminer Contest Workshop, in association with United Nations, Tehran, Iran, August 2002.
- [3] A. Jacoff, E. Messina, and J. Evans, *Experience in Deploying Test Arenas for Autonomous Mobile Robots*, Intelligent Systems Division, National Institute of Standards and Technology, Mexico, 2001.
- [4] *Human Machine Interface Standards*, Department of Energy Multilaboratory Project, 2003.
- [5] M.G. Naugle, *Illustrated TCP/IP*, (Book Style). John Wiley & Sons, 1998.
- [6] E. Wilson and S.M. Rock, *Reconfigurable Control of a Free-Flying Space Robot Using Neural Network*, American Control Conference. June, 1995, Seattle, Washington.
- [7] H. Mirmohammad-Sadeghi, H. Bastani and E. Azarnasab , *IUTMicrobot Robocup 2003 TDP*, Proceedings of the 2003 International Robocup 2003, Padova, Italy, 2003.
- [8] H. Bastani, *Motor drivers architecture, circuits and filtering*, ECERC internal technical report, 2002.
- [9] H.hada, K. Uehara , H. Sunahara , J.Murai , I. Petrovski , H. Torimoto , S. Kawaguchi , *Differential and RTK corrections for the internet car using GPS*, Nara Institute of Science and Technology & DX Antenna Co. Ltd, Japan .
- [10] N. Chayat, *Frequency hopping spread spectrum PHY of the IEEE 802.11 wireless LAN standard*, doc.: IEEE802.11-96/49D, BreezeCom, 1996.