

REVISIONS

No.	ZONE	ECN	CHANGE	DATE
-				

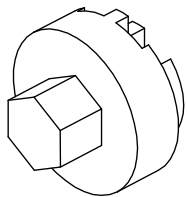
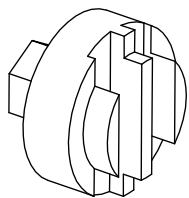
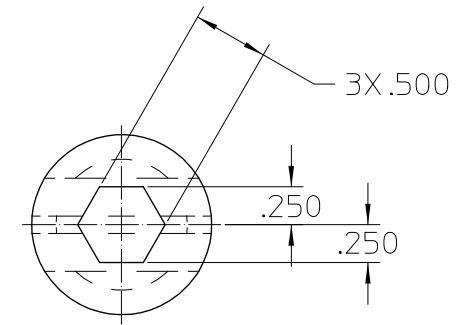
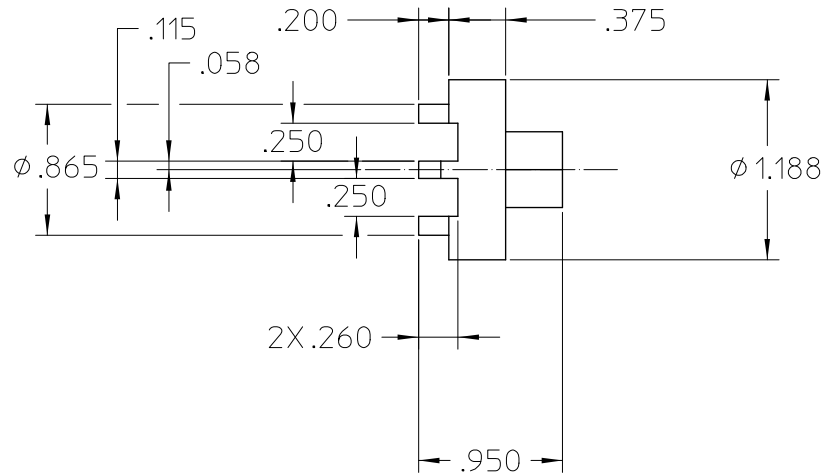
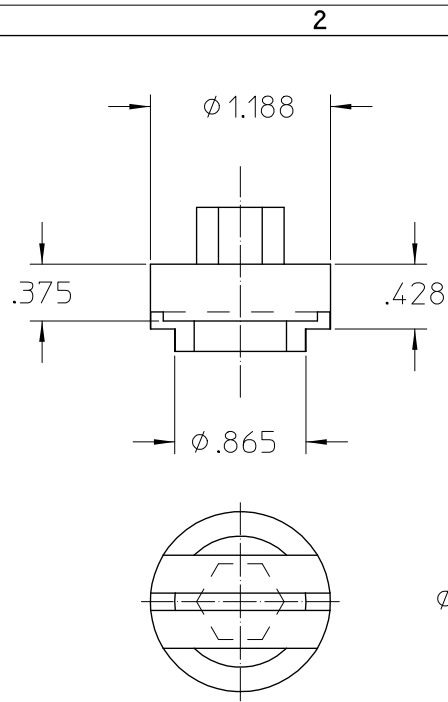

NOTES:

MATERIAL SPECIFICATION		APPROVALS		UNLESS OTHERWISE SPECIFIED DIMENSIONS ARE IN INCHES TOLERANCES ARE : DECIMALS FRACTIONS .XXX ±.005 ±.015 .XX ±.01 ANGLES ±.5	 National Institute of Standards and Technology Technology Administration, U.S. Department of Commerce	CENTER FOR NEUTRON RESEARCH	
MATERIAL STAINLESS STEEL, TYPE 303	ENGR	DATE				100 BUREAU DRIVE GAITHERSBURG, MD. 20899	
SIZE MATERIAL FORM BAR	ENGR MNGR	DATE			CG CELL WRENCH		
CAD DATA		ANNOTATION DRAWING DATA		DO NOT SCALE DRAWING	FOR		
PART NAME	STATE work	DATE 8/12/03 4:07 PM		THIRD ANGLE PROJECTION	SIZE B	DWG No. 003-1303	REV -
CREATOR Jim Larock	DATE 08/12/03	VERSION -	SHEETS		SCALE 1:1	RELEASE DATE	NEXT ASSY.
STATE work	DATE 8/12/03 4:07 PM	DRAFTER Jim Larock	DATE 08/12/03	ENGINEER Jim Larock	CALC. WT.	ACT. WT.	SHEET 1 of
LAST UPDATE BY jim	DATE 8/13/03 9:08 AM	LAST UPDATE BY jim	DATE 8/13/03 9:08 AM	PHONE # (301) 975-6239	DIM. & TOL. PER ANSI Y14.5M-1982		

2

1