

Appendix G

Multiple Dimension Measuring Devices Work Group Meeting Summary

October 28-29, 2014
Reynoldsburg, Ohio

	Page NTEP G/
PRELIMINARIES	2
<i>i. Introductions and Welcome of New Work Group Members (R. Kennington)</i>	2
<i>ii. Reiteration of NTEP Multiple Dimension Measuring Devices (MDMD) Work Group Mission. (J. Truex/D. Flocken)</i>	2
<i>iii. Goal of this Meeting. (J. Truex/D. Flocken)</i>	2
<i>iv. Report – 2014 NCWM Annual Meeting. (J. Truex)</i>	2
<i>v. Report – Activity of Measurement Canada. (Pascal Turgeon and Isabelle Tremblay [MC])</i>	2
<i>vi. Report – Recent NTEP MDMD Type Evaluation Activity. (J. Truex)</i>	3
CARRYOVER ITEMS	3
1. Review MDMD Meeting Minutes from 2010 meeting.	3
2. Review changes to NIST, Handbook 44, MDMD code since last meeting.....	4
3. Review changes to NCWM, Publication 14, MDMD Checklist.	4
4. Review changes to Measurement Canada MDMD Terms and Conditions.....	4
5. MDMD and the Mutual Recognition Agreement with Canada.	4
NEW ITEMS	5
6. Review current position/list of action items.	5
7. Review meeting activities and conclusions.	6
8. Define next steps.....	6
9. Next meeting.	6
<hr/>	
Sub-Appendices	NTEP Page F /
Sub-Appendix A: Meeting Handout of MC Definitions that Apply to Terms and Conditions	A1
Sub-Appendix B: Comparison Document of MC and U.S. MDMD Requirements.....	B1
Sub-Appendix C: Illustration of Measurement Canada’s Dimensional Standards.....	C1

PRELIMINARIES

i. Introductions and Welcome of New Work Group Members (*R. Kennington*)

ii. Reiteration of NTEP Multiple Dimension Measuring Devices (MDMD) Work Group Mission.
(*J. Truex/D. Flocken*)

Discussion:

Mr. Jim Truex (NTEP Administrator) and Mr. Darrell Flocken (NTEP Specialist) discussed the mission of the MDMD Work Group (WG) for the benefit of all participants. It was stated there is not much detail included in the NTEP checklist with regard to the testing of MDMDs. The MDMD WG is not considered an NTEP Sector. The mission of the WG is to deal with specific issues concerning MDMDs (i.e., to consider the requirements in NIST Handbook 44 [HB 44], and make sure NTEP has a type evaluation checklist in place to verify compliance with NIST HB 44 and influence factor testing). NTEP has been asked for years to consider encompassing MDMDs under the Measurement Canada (MC)/U.S. Mutual Recognition Arrangement (MRA). At a July 2014 NCWM meeting, Mr. Gilles Vinet (MC) announced Canada wishes to consider including MDMDs under the MRA umbrella with the United States. MC has requested to be lead laboratory. The NCWM Board of Directors is seeking input from MDMD WG with respect to this issue. This would be an annex to the current agreement.

iii. Goal of this Meeting. (*J. Truex/D. Flocken*)

Discussion:

The challenge is that this group must agree on a common type evaluation checklist. Equipment manufacturers check with MC because they have the most thorough checklist. The NTEP checklist must closely resemble MCs. Getting the technical stuff to agree is the challenge. Requirements between the two countries are similar, but they will never match exactly. We can deal with this. Can we overcome the differences in the checklists? That is the challenge.

iv. Report – 2014 NCWM Annual Meeting. (*J. Truex*)

Discussion/Update:

The NCWM Annual Meeting was well attended and went well, although there was some controversy concerning alternative fuels. There were no MDMD issues on the agenda. One Specifications and Tolerances (S&T) Committee agenda item involves a company from New Zealand (LoadScan, Ltd.) that manufactures a device, which can measure product in the bed of a truck or trailer. The company is seeking to include new requirements in NIST HB 44 that would address this device.

v. Report – Activity of Measurement Canada. (*Pascal Turgeon and Isabelle Tremblay [MC]*)

Note: This agenda item and Carryover Item 4. were combined into a single agenda item.

Discussion/Update:

The discussion of the combined items was led by Mr. Pascal Turgeon (MC) with additional input provided by Ms. Isabelle Tremblay (MC). Mr. Turgeon distributed three handouts to the WG as follows:

1. A handout of definitions that apply to terms and conditions titled “INTERPRETATION” (Oct 2014). A copy of this document can be found in Appendix A of this report.
2. A spreadsheet showing MC and NTEP checklist references in a side by side format with requirement descriptions. It was stated that this document was last updated in 2012. A copy of this document can be found in Appendix B of this report.
3. A handout titled “Comparison of MDMD Specifications to OIML R 129 and U.S. NIST HB 44 Code 5.58. (January 16, 2012).”

MC's project manager announced in July that MC would like to move forward with the MRA to include MDMDs. The goal is to achieve MRA (i.e., come to agreement on various requirements). OIML R 129 was last revised in 2000. If the WG agrees to something at this meeting that deviates from R 129, it may need to propose changes to R 129 when that document is opened again for revision.

MC is seeing more and more MDMDs being installed in the field and as a result it is receiving more requests for test boxes. A common problem is the weight of the boxes. Max weight of a test box should be 22 lb. New material will be used in the construction of test boxes (Mr. Turgeon passed around a sample of the new material for WG members to see). Different shapes for test objects are also being considered by MC. These will be "known" shapes.

MC may also be adding some new tests. Temperature tests are problematic with regard to full size versus smaller size devices. Some boxes are being wrapped with a black film, which requires different lasers to measure accurately. MC is considering tests for verifying accuracy when shrink wrap is used. If there are differences in MC and U.S. tests, this would not preclude a manufacturer from seeking a certificate from one of the two countries, (e.g., the United States, and not the other). With respect to freight overhanging a pallet, palletized freight is not addressed in NIST Handbook44 or OIML R 129.

vi. Report – Recent NTEP MDMD Type Evaluation Activity. (J. Truex)

Discussion/Update:

It was reported that the Ohio NTEP laboratory has had nine assignments in 2014, three of which were new manufacturers (or applicants) that had never submitted equipment to the Ohio lab. MC has had approximately three new devices, one of which is from a new applicant (i.e., a manufacturer MC had never worked with prior to 2014).

CARRYOVER ITEMS

1. Review MDMD Meeting Minutes from 2010 meeting.

Discussion:

It was stated that there were two follow-up items from the 2010 meeting as follows:

- (1) Develop a comparison of U.S. and MC type evaluation criteria.
- (2) One discussion topic at the meeting was the test objects used by MC.

With regard to the first item, a comparison spreadsheet was completed by Mr. Justin Rae (MC), which is the second document that was handed out by Mr. Pascal Turgeon in Agenda Item v.; a copy of which can be found in Appendix B of this report. With regard to the second item, Mr. Scott Davidson (Mettler-Toledo, Inc.) had distributed a copy of the test objects specifications. A copy of this document is included in Appendix C of this report.

Mr. Robert Kennington (Quantronix, Inc.), Chairman of the MDMD WG led a review of the 2010 meeting agenda. Items still of importance included on that agenda were identified as follows:

The standards used to test irregular objects – Mr. Joe Morrison (Ohio) pointed out that the Ohio lab uses an "L" shaped object to conduct such tests. MC uses several different shaped objects – refer to Appendix C of the 2014 MDMD meeting agenda to view illustrations of the different shaped objects used by MC.

- a. The rotation of an object into the smallest cuboidal box. Mr. Scott Wigginton (UPS) commented that UPS views this as a very significant issue. He stated that if we cannot get close enough on test requirements, there's no point in having a mutual arrangement because to obtain approval, a device would still need to be submitted to the different laboratories. Mr. Darrell Flocken agreed.

- b. The measurement of palletized objects.

2. Review changes to NIST, Handbook 44, MDMD code since last meeting.

Discussion/Update:

It was reported that there have been two changes to the NIST HB 44 MDMD code since the last WG Meeting (i.e., in 2010) as follows:

1. The title “Other Devices Designed to Make Multiple Measurement Automatically to Determine Volume” was added to paragraph A.2.
2. Paragraph N.1.4.3. Test Objects with Protrusions (shown in the box below) was deleted by adoption of a 2012 proposal. That is, the paragraph did not appear in the MDMD code after 2012.

N.1.4.3. Test Objects with Protrusions. – If the device is marked with a minimum protrusion dimension to be measured, a test object with protrusion shall be used to verify the marked limitation during type evaluation.

3. Review changes to NCWM Publication 14, MDMD Checklist.

Discussion/Update:

It was reported that there have been two changes to the MDMD checklist in NCWM Publication 14 since the last WG Meeting (i.e., in 2010) as follows:

1. The title of Section 8 “Accuracy” was changed to “Performance Tests” as the result of a 2010 MDMD WG recommendation.
2. A statement was added to the “Purpose” in Section 10. Influence Factor clarifying procedures to use for influence factor testing.

4. Review changes to Measurement Canada MDMD Terms and Conditions.

Discussion/Update:

Mr. Pascal Turgeon (MC) reported that the handout titled “INTERPRETATION (October 2014),” which was distributed when discussing Agenda Item v., depicted changes to MCs MDMD terms and conditions that were going to be adopted. He noted that blue text in the document provides the rationale for the requirement and is not actually part of the document. Maroon text identifies different terms defined in the Interpretation Section of the document.

5. MDMD and the Mutual Recognition Agreement with Canada.

Source:

NTEP Administrator

Background/Discussion:

The NCWM Board of Directors has directed NTEP to explore the possibility of expanding the scope of the NCWM/Canada Mutual Recognition Agreement (MRA) to include Multiple Dimension Measuring Devices. Measurement Canada (MC) has agreed to engage in discussions towards expanding the scope of the MRA. Key elements of this consideration are to discuss, develop, and identify 1) the impact to each country; 2) the pros/cons; and 3) a list of the difference in requirements and procedures between the two countries. Once these tasks are completed expansion of the MRA must be evaluated and agreed upon by MC and the NCWM.

Recommendation:

The WG is asked to identify the different checklist requirements and test procedures, U.S./NTEP vs MC, for MDMDs.

Conclusion:

Following the conclusion of the 2010 MDMD Work Group Meeting, Mr. Justin Rae (MC) developed a comparison summary of the requirements in NCWM Publication 14 verses those in the Measurement Canada Manual. The report was reviewed during the 2014 MDMD WG meeting to identify different checklist requirements and test procedures. This activity is ongoing as the WG is currently developing a joint U.S./MC type evaluation checklist.

NEW ITEMS

6. Review current position/list of action items.

Source:

NCWM Board of Directors / NTEP Committee

Background/Discussion:

The Work Group has been charged with the task of identifying and recommending changes to the current NTEP and Measurement Canada documents in order to permit the additional of MDMD Devices to be included in the Mutual Recommendation Agreement (MRA) on Type Evaluations. This charge is to include:

1. The comparison of specifications and tolerances between NIST HB 44 and the Measurement Canada Terms and Conditions and document all differences with the intent of addressing these differences in the evaluation checklist or recommend a change to the specification and/or tolerance one or both documents.
2. The comparison of the current NTEP and Measurement Canada Type Evaluation Checklist to identify differences that may be changed with the intent of harmonizing the two documents. An initial comparison has been made by Mr. Justin Rae of Measurement Canada, a copy of this comparison can be found in Appendix B of this agenda.
3. The NCWM Board of Directors and the NTEP Committee, at the suggestion of Measurement Canada, is asking the Work Group to consider recommending the Measurement Canada Evaluation Checklist be the primary document for the evaluation of MDMD Devices.
4. The NCWM Board of Directors and the NTEP Committee, at the suggestion of Measurement Canada, is also asking the Work Group to consider recommending that the Measurement Canada Evaluation Laboratory be identified as the primary laboratory for the evaluation of MDMD Devices.

Conclusion/Discussion:

With respect to Charges 1 and 2 of this item, the MDMD WG reviewed the comparison summary list of U.S. and MC requirements developed by MC and identified a number of differences in the type evaluation checklist criteria of the two countries. The WG agreed that changes would be needed to both the NCWM Publication 14 MDMD checklist and the MDMD Code of NIST HB 44 in order to better harmonize U.S./MC requirements. The WG developed a list of changes that would be needed and it is anticipated that this list will be used by the WG to develop future proposals to amend both NIST HB 44 and NCWM Publication 14.

With respect to Charge 3 of this item, the WG agreed to recommend that MC not be the primary document for the evaluation of MDMDs and that each country adopt its own checklist. The WG is currently developing a joint U.S./MC type evaluation checklist and intends to propose in the future, changes to both NIST HB 44 and the MDMD portion of NCWM Publication 14.

With respect to Charge 4 of this item, there was no consensus of the WG on this issue because: 1) it was reported that test data would not be mutually accepted if Canada were to be the primary laboratory; and 2) the time it takes for manufacturers to obtain a certificate through the MC lab due to a backlog of evaluations and custom issues. During the discussion of this charge, it was stated that the MRA is simply an acceptance of test data. Under the arrangement being considered, if MC is made primary lab, it would not accept U.S. type evaluation data but the United States would accept MC's type evaluation data. MC would perform tests that are included in the U.S. type

evaluation checklist even though some of the tests might be exclusive to the United States and not a part of MC's evaluation of a device.

7. Review meeting activities and conclusions.

Discussion:

The WG identified a total of six items that will require proposals to amend NIST HB 44. (*Technical Advisor's note*: A seventh item possibly requiring a proposal to amend NIST HB 44 is the gap in U.S. requirements needed to address multi-interval MDMDs. A small subgroup was formed to develop requirements that address multi-interval MDMDs for NIST HB 44 and NCWM Publication 14 MDMD. Members of the subgroup are as follows: Mr. Darrell Flocken, Mr. Rick Harshman, Mr. Scott Davidson, Mr. Justin Rae, and Mr. Scott Wigginton.

Ms. Isabelle Tremblay (MC) agreed to e-mail MC's current MDMD type evaluation checklist to Mr. Flocken and Mr. Harshman (i.e., the portions of the checklist that are considered fully developed).

8. Define next steps.

Conclusion:

The following next steps were identified:

- Mr. Rick Harshman is to distribute meeting notes to members of the WG at his earliest convenience.
- Mr. Harshman is to prepare a Draft MDMD WG Meeting Report and submit it to Mr. Robert Kennington, WG Chairman, for final approval. Once accepted, the report in final form will be forwarded to Mr. Jim Truex not later than December 12, 2014; that is, in time for submission to the NCWM.
- The WG agreed that recommendations to amend NCWM Publication 14 could not possibly be completed in time to submit them to the NTEP Committee for consideration in the current NCWM cycle. Consequently, it was decided that Mr. Truex will report to the Committee that a joint MC/U.S. type evaluation checklist is being developed by the MDMD WG. Proposals to amend NCWM Publication 14 and NIST HB 44 most likely could be made ready for submission in time to be considered in the 2016 NCWM cycle.
- Mr. Darrell Flocken volunteered to develop a new comparison document (or spreadsheet) that shows comparable U.S./MC paragraph references and provides indication of the WG's decisions to recommend amending NIST HB 44 and NCWM Publication 14. There were a few incorrect paragraph references in the comparison document developed by MC. Mr. Pascal Turgeon agreed to complete the necessary corrections and make Mr. Flocken aware of the changes so that he could include them in the new document that he will be creating. Mr. Flocken hopes to have the comparison document completed and distributed to members of the WG for their review in the March/April 2014 timeframe.

9. Next meeting.

The WG tentatively agreed to meet again in May of 2015; that is, shortly after distribution of the new comparison document being prepared by Mr. Darrell Flocken. It was decided that the meeting location would, once again, be Columbus, Ohio.

Sub-Appendix A: Meeting Handout of MC Definitions that Apply to Terms and Conditions

NIST Technical Advisor's Note: Shaded portions of the following document are comments that provide the rationale for the requirement and are not part of the actual document. Terms that are italicized in the document are defined in the Interpretation Section (i.e., Section 1 of the document).

INTERPRETATION (Oct 2014)

1. The following definitions apply in these terms and conditions.

“multiple-dimension measuring device” means a measuring machine that measures the *dimensions* of an object and determines the *hexahedral dimensions* of that object. (*appareil de mesure multidimensionnelle*)

“dimensions” means length, width and height, measured in units of length. (*dimensions*)

“hexahedron” means a geometric solid or box consisting of six rectangular planes. (*hexaèdre*)

“hexahedral dimensions” in respect of an object, means the *dimensions* of the smallest *hexahedron* within which an object can be contained. (*dimensions hexaédriques*)

“hexahedral volume” in respect of an object, means the volume of the smallest *hexahedron* within which an object can be contained. (*volume hexaédriques*)

- This term is intended to emphasize to a reader that the declared volume is that of the smallest hexahedron and not necessarily that of the object.

“interval” or “d” means the difference between two consecutively indicated values on an axis of a *multiple-dimension measuring device*. (*échelon ou d*)

“multiple-interval measuring range” means a measuring range consisting of two or more partial measuring ranges, each with a different *interval*. (*étendue de mesure à échelons multiples*)

“indicator” means that part of a *multiple-dimension measuring device* that displays measurements and information related to the measurement process. (*indicateur*)

“measuring element” means that part of a *multiple-dimension measuring device* that does not include the *indicator*. (*élément mesureur*)

“registration” means a displayed, printed or recorded representation of any measurement or other information required under these Specifications. (*enregistrement*)

“ready condition,” in respect of a *multiple-dimension measuring device*, means the condition of its being ready to make a measurement. (*état prêt*)

“zero reference,” in respect of a *multiple-dimension measuring device*, means the point from which a measurement is made. (*référence à zéro*)

“dimensional weight” means a numerical value calculated by applying a conversion factor to the *hexahedral dimensions* or *hexahedral volume* of an object for the purpose of determining postage, freight or storage charges. (*poids dimensionnel*)

“tare” means a value that is used to reduce the *dimensions* of an object. (*tare*)

“tare function,” in respect of a *multiple-dimension measuring device*, means a process, mechanism or feature that allows it to utilize *tare*. (*fonction tare*)

“influence factor” means an identified phenomenon or event to which a *multiple-dimension measuring device* is exposed and whose characteristics fall within the operating parameters of the device. (*facteur d'influence*)

“disturbance” means an identified phenomenon or event to which a *multiple-dimension measuring device* is exposed and whose characteristics fall outside the operating parameters of the device. (*perturbation*)

APPLICATION

2. These terms and conditions apply to *multiple-dimension measuring devices* that provide *hexahedral dimensions* for use in the calculation of freight, storage or postal charges.

DESIGN, COMPOSITION AND CONSTRUCTION

3. A *multiple-dimension measuring device* must be of a design, composition and construction that under normal conditions of use enable the device to measure accurately and do not facilitate the perpetration of fraud.
 - This section is intended to ensure that devices are designed and constructed in such a way that they are able to produce accurate measurements.
 - It is also intended to provide a general means of dealing with problematic device features that may not be addressed elsewhere in these terms and conditions.
4. A *multiple-dimension measuring device* must be designed and constructed in a way that enables inspection procedures and test standards to be applied to the device.
 - the intent of this section is to ensure that MDMDs are physically testable and have the necessary features to facilitate proper inspection of them.
5. A *multiple-dimension measuring device* must be equipped with a feature to indicate the software and any version of the software that it is using.
 - This section is intended to allow quick determination by inspectors, owners, manufacturers, and technicians that a device is or isn't utilizing software that has been identified as problematic.
 - It also facilitates corrective actions when new problems are found with an MDMD's software.
6. The interval of a *multiple-dimension measuring device* must be presented in a decimal format and must be
 - (a) equal to 1×10^n , 2×10^n or 5×10^n , where the power “n” is a positive or negative whole number or zero; or
 - (b) a binary submultiple of a Canadian unit of measurement set out in Schedule II to the *Weights and Measures Act*.
7. A *multiple-dimension measuring device* that has a multiple-interval measuring range must be configured as follows:
 - (a) the value of the *interval* of every measuring range must be less than the value of the *interval* of the subsequent measuring range ($d_1 < d_2 < d_3 \dots < d_r$);

- (b) the maximum length of every measuring range must be equal to the minimum length of the subsequent measuring range (min = min 1, max = max r, max 1 = min 2, etc.);
 - (c) the minimum length of every axis must be equal to the minimum length of the lowest measuring range of the axis; and
 - (d) the maximum length of every axis must be equal to the maximum length of the highest measuring range of the axis.
8. When measuring an object, a *multiple-dimension measuring device* that has a *multiple-interval measuring range* must automatically use the partial measuring range appropriate to the *dimensions* being determined.
- Having the interval size selected automatically makes the user's task easier and contributes to the accurate measurement of packages.
9. A *multiple-dimension measuring device* must be equipped with the following items:
- (a) an indicator or printer that has indicating or recording elements with digits of a design, number and size that permit a clear indication of accurate measurement; and
 - (b) if it is installed with two or more measuring elements connected to a single primary indicator or printer that is separated from one or more of its measuring elements by a distance that does not allow easy inspection, a portable indicator that:
 - (i) is configured to provide the same information as the primary indicator or printer;
 - (ii) provides information that is in exact agreement with the information provided by the primary indicator or printer; and
 - (iii) is readily connectable to all of the measuring elements without affecting the performance of those elements.
- This is to facilitate inspections.
 - It allows inspection of the MDMD at the remote measuring element using the portable indicator.
10. A *multiple-dimension measuring device* that has a means of registration that is connected to two or more *measuring elements* must be equipped with features that:
- (a) automatically identify the *measuring element* that is providing the displayed information; and
 - (b) prevent the activation of any *measuring element* that is not in use.

paragraph a)

- The purpose is to let interested parties know which measuring element is doing the measuring and thus observe the process for any problems.
- It is also for use in complaint investigations or follow up actions by identifying the potential source of a problem.

paragraph b)

- The purpose of paragraph b) is to allow an operator to deactivate a measuring element for any reason deemed necessary.

11. A *multiple-dimension measuring device* that is equipped with an *indicator*, which consists of display elements or segments that may fail individually and produce incorrect information, must have a display test mode that shows all relevant elements and segments of the *indicator*.
 - This section is aimed at indicators that consist of individual display elements or segments which can fail or burn out.
 - The failure of individual segments results in an indicator that appears to be operating properly but which is producing erroneous information.
 - For example, an individual element might stay on when it should be off or might be off when it should be on.
 - This section is included to provide an operator or inspector with a quick way to determine if the display segments are operating correctly.
 - Other types of indicators, such as computer monitors, that do not fail in this way are exempt from this section.

12. A *multiple-dimension measuring device* must not provide a measurement registration until the operating temperature necessary for accurate measurement has been attained.
 - This section is to ensure accurate measurement.
 - A specific temperature does not have to be stated by the MDMD manufacturer.

13. (1) A *multiple-dimension measuring device* must be equipped with a feature by which the zero reference or ready condition can be established.
(2) The feature must be interlocked so that its use is prevented during measurement.
Subsection (1)
 - The purpose is to facilitate accurate measurement.Subsection (2)
 - The purpose is to prevent inadvertent or deliberate measurement errors.

14. (1) A *multiple-dimension measuring device* must automatically maintain a *zero reference* or *ready condition* when no object is in or on the *measuring element* or when a *zero reference* or a *ready condition* has not been established and maintained; must not provide any measurement *registrations*.
(2) When a *zero reference* or *ready condition* has been established, a *multiple-dimension measuring device* must indicate that fact.
 - For most applications and for most operators, it is desirable to have the zero maintained automatically.
 - However, when the zero or ready condition is lost, the MDMD must stop providing measurements.
 - The purpose of Subsection (2) is to allow an operator to clearly see that the equipment is ready for use.
 - This can be done in various ways and will normally be described in the NoA.

15. The measurement *registrations* of a *multiple-dimension measuring device* and any equipment or accessories connected to the device or used in conjunction with it must:
- (a) agree exactly;
 - (b) be clear, accurate and unambiguous; and
 - (c) when provided in printed form, be printed indelibly.
- The purpose of this section is to ensure that all forms of measurement registration provided by a device and all of the equipment used in conjunction with the device, including metrological information transferred or downloaded to a computer, meet the requirements of this section.
 - This requirement doesn't apply to information being used for non-trade or internal company purposes.
 - Dimensional weight is not a measurement registration.
16. The measurement *registration* of a *multiple-dimension measuring device* must:
- (a) be expressed in the same unit of measurement for each of the three axes;
 - (b) be expressed in a single unit of measurement; and
 - (c) include the name or symbol of the unit of measurement.

The objectives of this section are simplicity and clarity.

paragraph (a)

- Having each of the dimensions in the same unit is easier to read.

paragraph (b)

- Prevents the use of mixed units such as cm/mm, feet/inches when quantifying a measurement.
- Examples: 8.7 cm or 87 mm are acceptable whereas 8 cm, 7 mm is not.
30 inches or 2.5 feet are acceptable whereas 2 feet, 6 inches is not.

17. (1) A *multiple-dimension measuring device* that provides a measurement *registration* of the *hexahedronal volume* of an object must also provide the *hexahedronal dimensions* of the object.
- (2) A *multiple-dimension measuring device* must not express the dimensional weight of an object in any unit of measurement that is set out in Schedule I or II to the *Weights and Measures Act*.

Section 17 (1)

- The reason for this is that the volume is calculated, not measured, and when following up on a complaint or an enquiry, it's the measured dimensions that will be important to the investigation.
- A calculated volume can be the result of more than one set of dimensions.

For example:

$$20 \text{ cm} \times 30 \text{ cm} \times 15 \text{ cm} = 9\,000 \text{ cm}^3$$

$$20 \text{ cm} \times 25 \text{ cm} \times 18 \text{ cm} = 9\,000 \text{ cm}^3$$

Section 17 (2)

- Dimensional weight is a calculated value, not an actual weight and as such may not be accompanied by a unit of measurement on the MDMD indicator.
 - This subsection only applies to the MDMD and not to a printed dimensional weight.
 - The reason is that dimensional weight is not a measurement registration. (see Section 15)
18. A *multiple-dimension measuring device* must not provide a negative measurement *registration* except when it indicates a tare.
- The purpose of this section is to prevent any miscalculations or errors as a result of the inadvertent inclusion of a negative registration in a calculation.
 - Examples of what might be tared; handles on a case, strapping protrusions on a carton, the height of a pallet.
 - Neither this section nor any other section requires that an MDMD must have tare capabilities.
19. (1) The tare function of a *multiple-dimension measuring device* must operate only in a negative direction in relation to the *zero reference* or the *ready condition*.
- (2) A *multiple-dimension measuring device* must clearly indicate when the tare function is in use.
- (3) The value of the tare *interval* must be equal to the value of the *interval* of the respective axis and range in use by the *multiple-dimension measuring device*.
- (4) A *tare* may be less than the minimum length marked on a *multiple-dimension measuring device* for each axis to which the *tare* refers.
- (5) When a *tare* is used, it must be displayed.
- Subsection (1) is to ensure that a tare function can only be used to reduce a length measurement.
 - Subsection (2) is meant to a) allow an operator to see that the tare is active when it is called for as well as to prevent the inadvertent use of the tare function when it isn't called for and b) allow a customer to see that a tare is being used.
 - Subsection (3) is to ensure accurate measurement
 - Subsection (4) allows a tare value to be less than 12 d. (Section 32)
 - Subsection (5) shows the amount of the tare.
20. A *multiple-dimension measuring device* must not provide any measurement *registration*, or must indicate an error message with its measurement *registration*, if the object being measured:
- (a) is smaller than the minimum *dimensions* marked on the device;
 - (b) is larger than the maximum *dimensions* marked on the device plus 9 d; or
 - (c) has *dimensions* that exceed the measurement capability of the device.

- This section requires that an MDMD either not provide measurements or display an error message with the measurements, when the measurements of an object are beyond the marked capabilities of the MDMD.
- Paragraph a) also applies to net measurements that are less than 12 d as a result of the use of a tare.
- Paragraph b): an MDMD can blank at the marked maximum length or any number of additional “d” up to + 9 d. For example, an MDMD that blanks at maximum length + 4 d is acceptable.
- Paragraph c) is to address devices that can’t measure maximum height and maximum width at the same time but that can otherwise measure the maximum height of narrow objects or the maximum width of short objects.

21. (1) A *multiple-dimension measuring device*, its auxiliary equipment or its system must record and provide every customer, either by printed statement or electronic data transmission, the following information in respect of each object measured by the device:

- (a) the identification number or code of the object;
- (b) when it determines the weight of the object for postage, freight, or storage charges, the weight of the object; and
- (c) when it determines the *hexahedral dimensions* of the object for postage, freight, or storage charges:
 - (i) the *hexahedral dimensions* of the object;
 - (ii) the *dimensional weight* of the object if calculated; and
 - (iii) if more than one device or measuring element is installed in the same premises, the device identification.

Subsection 21 (1)

- The information is provided to the customer to assist the customer when he or she has a question or a concern about the measurements or the transaction.
- The information can be provided by either the MDMD itself or some other component in the system.
- This subsection applies in non-retail locations such as a couriers sorting facility.
- This subsection only applies when the packages are to be invoiced by dimensions or weight.
- The subsection does not specify when the information must be provided.
- The information is normally included on the customer’s invoice but could alternatively be sent to the customer in electronic form.

object identification [paragraph (a)]

- This is typically being done with a bar code on the package or object and a corresponding number/code provided on the invoice for the package.
- The object identifier must be accompanied by either the weight [paragraph (b)] or the dimensions of the object [paragraph (c)].

weight of the object [paragraph (b)]

- When the MDMD or its system includes a scale, this is the actual weight of the object as determined by the scale.
- This terms and conditions does not prohibit manually entered weights; however, when used, they must be used in a manner that ensures accurate measurement. [see paragraph 29(a)].
- When the weight of the object is used to determine the fee for the package, 21 (1) (c) does not apply.

hexahedral dimensions [paragraph (c)]

- they are usually presented as L x W x H with a unit of measurement. (Section 16)
- when the hexahedral dimensions of the object are used to determine the fee for the package, the weight of the package does not have to be provided.

dimensional weight [sub paragraph (c) (ii)]

- Dimensional weight is a calculated value; it is not a weight.
- It is typically calculated using a formula that divides the hexahedral dimensions or hexahedral volume of an object by a conversion factor.
- The conversion factor and formula are both determined by the courier.
- Dimensional weight is only required when it has been calculated which would probably be most transactions.
- The dimensional weight may have a unit when given on an invoice, but it must be clearly identified as a dimensional weight [sub Section 21(3)]. For example, the letters “dw” or “dim” between the value and the unit.

Device identification [sub paragraph (c) (iii)]

- This refers to the MDMD that measured the object.
 - The owner/operator of the MDMDs determines how to identify the MDMDs.
 - This sub-paragraph is to facilitate the investigation of complaints or other issues related to the measurements used in a transaction.
 - It only needs to be provided once on an invoice if all of the packages were measured by the same MDMD.
- (2) A *multiple-dimension measuring device*, its auxiliary equipment or its system must provide every customer who is present at the time of measurement with a printed statement setting out the following information in respect of each object measured by the device:
- (a) the identification number or code of the object; and
 - (b) when it determines the weight of the object for postage, freight or storage charges, the weight of the object;
 - (c) when it determines the *hexahedral dimensions* of the object for postage, freight, or

storage charges:

- (i) the *hexahedral dimensions* of the object;
- (ii) a statement indicating that the *dimensions* are those of the smallest *hexahedron* within which the object can be contained;
- (iii) the *dimensional weight* of the object, if calculated;
- (iv) the conversion factor used to calculate the *dimensional weight* of the object; and
- (v) a statement indicating that the *dimensional weight* of the object is a calculated value obtained by applying a conversion factor to those *dimensions* and is not the actual weight of the object, if the *dimensional weight* is calculated.

Subsection 21 (2)

- The information is provided to the customer to assist the customer when he or she has a question or a concern about the measurements or the transaction.
- The information can be provided by either the MDMD itself or some other component in the system.
- This Subsection applies in situations where the customer is present at the time of measurement such as a retail store.
- The information must be provided to the customer at the time of measurement.
- This subsection only applies when the packages are to be invoiced by hexahedral dimensions or weight.

smallest hexahedron statement [sub paragraph (c) (ii)]

- The statement is only required when the hexahedral dimensions are used in the determination of the fee.
- The text of the statement can be different than the text in the subparagraph as long as it conveys the same message.
- The statement can be pre-printed on the receipt or invoice.
- The purpose of the statement is to make clear to a customer that the declared dimensions are of the smallest hexahedron.

conversion factor [sub paragraph (c) (iv)]

- This is the factor (for example, 6 000 cm³ / kg) that is being used to convert the hexahedral dimensions or volume of the measured object into a dimensional weight.
- The factor is only required when the dimensional weight has been calculated.
- It's required for direct sales transactions to ensure that customers who do not have a contract with the courier will know what factor was used in the determination of the fee.

dimensional weight statement [sub paragraph (c) (v)]

- The statement is only required when a dimensional weight has been calculated.
 - The text of the statement can be different than the text in the subsection as long as it conveys the same message.
 - The statement can be pre-printed on the receipt or invoice.
 - The purpose of the statement is to make clear to a customer that the dimensional weight is not the actual weight of the object but rather a calculated value.
- (3) The *dimensional weight* of an object must be clearly identified as a *dimensional weight*.

Subsection 21 (3)

A dimensional weight can be confusing because it's often presented with a unit of measurement and sometimes mixed on invoices with actual weights. Because of this, a dimensional weight must be identified as such (i.e., a code, a message, a symbol, etc).

22. (1) If the information required to be provided under Section 21(1) is provided by electronic data transmission, a *multiple-dimension measuring device*, its auxiliary equipment or its system must retain the information for a minimum of 90 days following the date on which the information was initially transmitted by the device, its auxiliary equipment or its system.
- (2) The information required under Section 21(2) (c) (ii), (iv) and (v) may be preprinted on the printed statement.

Subsection 22 (1)

- This does not apply to information that is provided to customers via hard copy invoices or statements.
- This subsection does two things:
 - it ensures that a customer has enough time to review his invoicing information; and
 - provides a customer with access to the information should his or her files be lost or damaged after receipt of the original data transmission.

Subsection 22 (2)

- The statements only need to be provided once on the printed statement.
 - the conversion factor only needs to be provided once on the invoice unless more than one conversion factor is used.
23. The adjustable components of a *multiple-dimension measuring device* must maintain a setting after any adjustment is made.
- The purpose of this section is to ensure dependable and accurate devices.

24. (1) Access to the metrological functions and the adjustable components of a *multiple-dimension measuring device* must be protected by means of readily accessible and observable physical seals or electronic sealing, such as an audit trail, that make apparent any accessing of the metrological functions or adjustable components.
- (2) The information contained in an audit trail must be available and printable on site.
- (3) In this section, “audit trail” means an electronic feature that counts the number of changes made to the calibration or configuration parameters of the device or records the values related to these changes.

Subsection 24 (1)

- Seals are required to restrict access to metrological functions and adjustments that are necessary for the correct operation of an MDMD.
- The seals need to be readily visible so that missing or broken seals will be visible to MDMD users who may then take the necessary steps to deal with the situation.
- The NoA will provide sealing information.
- An audit trail method of security is an acceptable alternative to physical seals, but it must be readily accessible so as to allow easy determination of any changes made to the device.
- An audit trail is subject to the Terms and Conditions for the Approval of Metrological Audit Trails (March 01, 2006).
- Sealing may be a combination of physical seals and an audit trail.

Subsection 24 (2)

- Subsection (2) is to assist an inspector during an inspection.
- The print requirement is to eliminate the need for an inspector to copy information by hand.

25. A *multiple-dimension measuring device* that is equipped with interfaces that allow the connection of auxiliary equipment must be designed so that:

- (a) the metrological functions of the device are not adversely affected by either the operation of the auxiliary equipment or by disturbances or influence factors acting on the auxiliary equipment or interfaces; and
- (b) the interfaces do not allow access to the metrological functions and adjustable components of the device.

Section 25, paragraph (a)

- The cables, connectors and interface ports or ancillary equipment should not be an access route by which interference or disturbances can enter and detrimentally affect the operation and performance of the MDMD or the system as a whole.

Section 25, paragraph (b)

- The interface ports should not be a way to access the metrological functions and adjustments of the

MDMD.

- This requirement does not apply to ports designed for setting up and making adjustments to an MDMD and that would be sealed as per subsection 24 (1).

26. A *multiple-dimension measuring device* must be designed to operate over a temperature range of -10°C to $+40^{\circ}\text{C}$ unless a different temperature range is specified by its manufacturer, in which case it must operate over a temperature range of at least 30°C .

This section requires that MDMDs operate satisfactorily over the temperature range that MDMDs are usually used at.

- The 30°C reference in this section represents a temperature range and not a specific temperature.
- When expressing metric temperatures, there must be a space between the numeric value [40] and the symbol [$^{\circ}\text{C}$]. For example, 40°C not 40°C .

MARKING

27. (1) A *multiple-dimension measuring device* must be clearly and permanently marked with the following information:

- (a) the approval number;
- (b) the manufacturer's name;
- (c) the model designation;
- (d) a serial number;
- (e) the minimum and maximum length for each axis;
- (f) the *interval* for each axis and measuring range;
- (g) the minimum and maximum operating speeds; and
- (h) the temperature range, if other than -10°C to $+40^{\circ}\text{C}$.

- (2) The information must be marked on the *multiple-dimension measuring device* or on a descriptive plate affixed to it that is clearly visible at all times.

- The information is provided for identification purposes and to inform operators of the capabilities of the MDMD.
- The information marked must reflect the approved values and limits.
- The minimum length referred to in 27 (1) (e) is the minimum length that the MDMD can be used to measure (i.e., 12 d).
- Some of this information may not be applicable to some MDMDs. (i.e., multiple measuring ranges, operating speeds)

28. If there are any restrictions, limitations, or conditions on the use of a *multiple-dimension measuring device* or if there are any special applications or uses for it, that information must be clearly and permanently marked

on the device or be posted in close proximity to the device so as to be clearly visible to the operator and any customer who is present at the time of the measurement.

- The purpose of this section is to ensure that operators are aware of any applications and restrictions that apply to the MDMD they are using so that they may take whatever precautions are necessary.
- This section also alerts a customer to these factors and may assist in preventing inaccurate measurements.
- Restrictions, limitations, etc. for an MDMD are found on its NoA.

INSTALLATION AND USE

29. A *multiple-dimension measuring device* and any equipment or accessories connected to or used in conjunction with it must be installed, maintained and used in a manner that:

- (a) ensures accurate measurement;
- (b) respects the parameters, restrictions, limitations and conditions of use set out in the notice of approval issued for the device;
- (c) is in accordance with the manufacturer's or importer's instructions;
- (d) does not detrimentally affect the performance of the device; and
- (e) does not facilitate the perpetration of fraud.

- The purpose of this section is to establish conditions that will maximize the occurrence of accurate measurement results.

30. A *multiple-dimension measuring device* must be suitable for its intended use with respect to the elements of its design, composition and construction.

- This section places the responsibility to use a device that has features and capabilities, which are suitable for the measurement task at hand, on the operator of a device.
- Factors such as interval size, capacities, units of measurement, operating speeds, and shape restrictions are usually considered.

31. Every *multiple-dimension measuring device* must be positioned and maintained so that all measurement indications and related information may be easily read, and the measurement of the object observed, by a customer who is present at the time of the measurement.

- The purpose of this section is to ensure that an MDMD is installed so that a customer can see the actual measurement process and the information displayed during the process.
- This allows a customer to see that the measurement was done correctly, or if he has questions about the process, discuss the concern with the operator.
- Customer line of sight is not required for secondary indications or supplemental information displayed away from the normal position of the customer.

32. The minimum net length to be measured by a *multiple-dimension measuring device* is 12 d for the axis and measuring range in use.

- The purpose of this section is to prevent the device from being used to measure an object for which the

limit of error is inappropriately large in relation to a dimension of the object.

- Section 33 tells us that the limit of error is 1 d.
- IF we divide 1 d by a given length, also in terms of d, we can determine the limit of error as a percentage of the length. Some examples; $1 d \div 10 d = 10 \%$, $1 d \div 5 d = 20 \%$,
- The 12 d restriction represents a limit of error of 8.3 %: $1 d \div 12 d = 8.3 \%$
- The minimum length that can be measured can be different for each axis.
- The minimum length of each measuring range must be equal to or greater than 12 times its “d” value.

For example, range 1 has a d = 5 mm and range 2 has a d = 10 mm. Range 1 must extend to at least 120 mm or 24 d.

PERFORMANCE

33. Subject to Section 35, the acceptance and in-service limits of error for *registrations* and tests of a *multiple-dimension measuring device* are $\pm 1 d$ for the axis and measuring range in use.
- This limit of error applies regardless of the shape, material or position of the object being measured, the type of inspection being done (i.e., approval, initial, control, zone) or the design or type of the device.
 - This limit of error is the same as that of the United States (NIST HB 44) and OIML R 129.
34. A *multiple-dimension measuring device* must perform within the applicable limits of error when it is tested under controlled conditions for the following influence factors:
- (a) any voltage from $- 15 \%$ to $+ 10 \%$ of the nominal voltage for devices that use alternating current electricity as a power source;
 - (b) any voltage level at which the device is capable of displaying measurement *registrations* for devices powered by direct current electricity;
 - (c) any temperature within the temperature range marked on the device or, if no range is marked, at any temperature within the range of $- 10 \text{ }^\circ\text{C}$ to $+ 40 \text{ }^\circ\text{C}$;
 - (d) humidity variations at any level up to 85 % relative humidity, at any temperature within the temperature range specified for the device;
 - (e) ambient light level variations, at any light level intensity from 100 lx to 1500 lx for devices using optical principles of operation;
 - (f) any acoustic interference, at intensity levels of up to 100 db at the nominal centre frequency of the ultrasonic transducers used in the device, for devices using acoustic principles of operation; and
 - (g) any other influence factor that may affect the device's performance.
- The purpose of this section is to provide device manufacturers with a set of conditions under which a device must be able to perform properly.
 - Paragraph g) is included to allow the Approval Services Laboratories to test features that are not covered by the other sections.

- These test conditions are for approval purposes and are not used during routine field inspections.
35. The difference between a measurement *registration* subjected to a disturbance, such as electromagnetic or electrostatic fields, short-time power reduction, electrostatic discharges, electrical bursts or other disturbances, and an undisturbed measurement *registration*, must not exceed 1 d. If the difference exceeds 1 d, the *multiple-dimension measuring device* must:
- (a) blank the *registration* and prevent the transmission, printing and storage of measurement results;
 - (b) provide an error message and prevent the transmission, printing and storage of measurement results;
or
 - (c) provide a measurement *registration* that is so completely unstable that it cannot be interpreted or transmitted into memory or to a printer as a correct measurement result.
- The purpose of this section is to provide MDMD manufacturers with conditions under which an MDMD must be able to either perform properly or respond in a specified way.
 - These disturbances might be so strong that the MDMD won't be able to operate properly, so other responses are allowed (i.e., blanking, error messages).

CHANGES TO THE REGULATIONS

1. The portion of Section 21 of the Weights and Measures Regulations before paragraph (a) is replaced by the following:

21 Before being sold, leased or otherwise disposed of, a weighing machine (other than a weighing device to which the *Terms and conditions Relating to Non-automatic Weighing Devices (1998)* apply) or a measuring machine (other than a multiple-dimension measuring device to which the *Multiple-dimension Measuring Device Terms and conditions apply*) that is of a class, type or design approved under Section 3 of the Act, and any equipment or accessory attached to or used in conjunction with the machine that has or could have an effect on the accuracy of the machine and that was approved under Section 3 of the Act shall be marked with the following information:
2. Subsection 65(2) of the Regulations is replaced by the following:

65 (2) Weighing devices to which the *Terms and conditions Relating to Non-automatic Weighing Devices (1998)* apply and multiple-dimension measuring devices to which the *Multiple-dimension Measuring Device Terms and conditions* apply are exempt from this Part.

THIS PAGE LEFT INTENTIONALLY BLANK

Sub-Appendix B: Comparison Document of MC and U.S. MDMD Requirements

MC Requirements			NTEP Requirements		
Markings (Section 1)			Markings (Section 1)		
MC Manual	MC Spec	Description	Pub. 14	Handbook 44	Description
1.1.1	27.1b	name of manufacturer	1.1	G-S.1.	name of manufacturer
1.1.2	27.1c	model number	1.2	G-S.1.	model number
1.1.3	27.1d	serial number	1.3	G-S.1.	serial number
1.1.4	27.1a	approval number	1.5	G-S.1.	approval number
1.1.5	27.1e	min and max dimensions	1.8.1	G-S.1.	min and max dimensions
1.1.6	27.1f	interval or “d”	1.8.2	G-S.1.	interval or "d"
1.1.7	27.1g	min and max operating speeds	1.8.4	G-S.1.	min and max operating speeds
1.1.8		area for verification marks	none		
1.1.9	28	minimum spacing	1.8.6	G-S.1.	limitations
	27.1h	temperature range	1.8.3	G-S.1.	temperature range
LG-1.01	27.1	Lettering Permanence	1	G-S.1.	Lettering Permanence
LG-1.02	27.1	Label/Plate Permanence	1.7	G-S.1.	Label/Plate Permanence
1.3	5	Software markings	1.4	G-S.1.	Software markings
1.6	28	Special Application	1.8.5	G-S.1.	Special Application
1.6	28	Limitations	1.8.6	G-S.1.	Limitation of Use
	27.2	Location of Markings	1.6	G-S.1.	Location of Markings
	none		1.9	G-S.1.	Software Markings Location
1.7	29,30,31	Marking Control, Annunciators	none		
			Design of Indicating or Recording Elements (Section 2)		
MC Manual	MC Spec	Description	Pub. 14	Handbook 44	Description
3.1.1	9a	registrations in decimal format	2.2	S.1.2.	registrations must be in a digital format
3.1.2	6a	indications of 1, 2 or 5	2.5.1, 2.5.2	S.1.5.	registrations of 1, 2 or 5
3.1.3	6b	binary submultiple	2.5.3	S.1.5.	binary submultiples
3.2.1	9a, 15b	reading results is easy, unambiguous	none		
3.2.2	9a, 15b	digits of uniform size, shape and character	2.2	S.1.2.	registrations must be in a digital format
3.2.3	15b	no interference with interpretation of measurement	none		

NTEP Committee 2015 Final Report
Appendix G – 2014 NTEP MDMD Work Group Meeting Summary
Sub-Appendix B – Comparison Document of MC and U.S. MDMD Requirements

Table Continued:

Indication and Display Features (Section 3)			Design of Indicating or Recording Elements (Section 2)		
MC Manual	MC Spec	Description	Pub. 14	Handbook 44	Description
3.2.4	16a	same unit of measurement of all axes		none	
3.2.5	16b	only one unit of measurement may be used		none	
3.2.6	16c	L,W,H and units marked and are acceptable		none	
3.2.7	15b	separated by decimal point or comma		none	
3.2.8		no fixed zeros		none	
3.2.9	16b	tare and net in same units		none	
3.2.10		rounding followed		none	
3.2.11		"L, W, H" indicated		none	
3.3.1		Video display - dedicated area for measurement display		none	
3.4.1		Volume displayed correctly (units, significant figures, etc.)		none	
	17	If Volume displayed, dimensions must be provided on demand	2.4	S.1.4.	Only volume indicated - test mode for dimensions
		0.3, 0.4 inch division sizes not permitted	2.5.4, 2.5.5	S.1.5.	Indirect Sales: 0.3 and 0.4 inch "d"
		no spec for different "d"	2.5.6	S.1.5.2.	"d" in x and y different from z
Recorded Representations (Section 4)			Design of Indicating or Recording Elements (Section 2)		
MC Manual	MC Spec	Description	Pub. 14	Handbook 44	Description
4.1	15c	permanent, legible, same units	2.2	S.1.2.	registrations must be in a digital format
4.2	15b	clearly defined		none	
4.3	15a	same number of decimal places		none	
4.4	16b	unit conversion: proper values		none	
4.5	15b	G, N, T, Total Price, Unit Price in agreement		none	
Annunciators and Symbols (Section 5)			Design of Indicating or Recording Elements (Section 2)		
MC Manual	MC Spec	Description	Pub. 14	Handbook 44	Description
5.1	16c	Appropriate figures, words or symbols		none	
5.2	15b	Metrological annunciators properly defined		none	
5.3	15b	Names, symbols are suitably located		none	
5.4	16b	Unit key must automatically change indicated & printed G,N,T units		none	
5.5		DIM Weight Defined and Correct		none	
Agreement of Registrations (Section 6)			Design of Indicating or Recording Elements (Section 2)		
MC Manual	MC Spec	Description	Pub. 14	Handbook 44	Description
LG-6.01	15a	Digital values of like value - exact agreement		none	
LG-6.02	15b	Suitability of unit conversion		none	

NTEP Committee 2015 Final Report
Appendix G – 2014 NTEP MDMD Work Group Meeting Summary
Sub-Appendix B – Comparison Document of MC and U.S. MDMD Requirements

Indicating Zero, Negative and Ready (Section 7)			Design of Zero and Tare (Section 4)		
MC Manual	MC Spec	Description	Pub. 14	Handbook 44	Description
7.1	14(2)	means to indicate zero or ready	2.1, 4.1	S.1.1., S.2.	means to indicate zero or ready
7.2	13(1)	not-ready or off zero on both sides of zero			
7.3	14(1)	automatic maintain zero or ready, or inhibit	2.1, 4.1	S.1.1., S.2.	inhibit measurements if not ready/zero
7.4		no + or - at zero	none		
7.5	18	display negative when gross < tare	2.3	S.1.3.	negative values not displayed unless in tare mode
7.6	18	negative indication cannot be confused	none		
7.7	18	blanking display when under zero	none		
Limits of Indication (Section 8)			Design of Indicating or Recording Elements (Section 2, 11)		
MC Manual	MC Spec	Description	Pub. 14	Handbook 44	Description
LG-8.01	20a, 32	under minimum (12d)	2.7, 11	S.1.7.	under 12 d
LG-8.02	20b, 20c	over maximum (max + 9d)	2.8, 11	S.1.8.	over max + 9d
Zero Activate During Measurement (Section 9)			Design of Zero and Tares (Section 4)		
MC Manual	MC Spec	Description	Pub. 14	Handbook 44	Description
9	13(2)	zero/ready control interlock	4.2	S.2.	zero/ready control interlock
Return to Zero (Section 10)			(Section)		
MC Manual	MC Spec	Description	Pub. 14	Handbook 44	Description
10	13,14	Return to Zero Test	2.1, 4.1		zero/ready condition
Tare (Section 11)			Design of Zero and Tare (Section 4)		
MC Manual	MC Spec	Description	Pub. 14	Handbook 44	Description
11.1.1	19(1)	Tare operates in backward direction only	4.3	S.2.	Tare operates in backward direction onl
11.1.2	15b	Entry of zero tare	none		
11.1.3	19(3)	d tare = d	4.4	S.2.	d tare = d
11.1.4	20	Sum of Tare and Net weight < gross load capacity	none		
11.1.5		NET + Tare = GROSS weight	none		
11.1.6	16b	Tare - selecting units of measurement - accuracy and rounding.	none		
11.1.7		Automatic clearing of tares	none		
11.1.8		Tare non-additive	none		
11.1.9	19(2)	Visual confirmation of Tare entry	4.5	S.2.	clear indication Tare has been taken
LG-11.01		Tare Test	none		
11.2.1		tare entry only at gross load zero	none		
11.2.2		Tare may be retained between transactions	none		

NTEP Committee 2015 Final Report
Appendix G – 2014 NTEP MDMD Work Group Meeting Summary
Sub-Appendix B – Comparison Document of MC and U.S. MDMD Requirements

Table Continued

Tare (Section 11)			Design of Zero and Tare (Section 4)		
MC Manual	MC Spec	Description	Pub. 14	Handbook 44	Description
11.3.1		tare cancellation if there are means to indicate tare value		none	
11.3.2		Tare may be retained between transactions		none	
Segment Verification (Section 12)			(Section)		
MC Manual	MC Spec	Description	Pub. 14	Handbook 44	Description
12	11	Segment Verification Test		none	
Multiple Measuring Elements (Section 13)			Multiple Measuring Elements (Section)		
MC Manual	MC Spec	Description	Pub. 14	Handbook 44	Description
13.1.1	10b	Prohibit activation of measuring elements not in use	5.1	S.3.	Prohibit activation of measuring elements not in use
13.1.2.	10a	Indicating which measuring element is used	5.2	S.3.	Indicating which measuring element is used
13.1.3		Weighing elements are identified		none	
13.1.4	10a	Recording which weighing element is used		none	
13.1.5		Performing a function on a particular weighing element does not affect other elements		none	
13.1.6	14	Zero or ready must remain active		none	
	9b	Portable indicator			
Multiple Interval (Section 14)			(Section)		
MC Manual	MC Spec	Description	Pub. 14	Handbook 44	Description
14.1.1	7a	$d1 < d2 < d3$		none	
14.1.2		Gross = Net + Tare		none	
14.1.3		Gross = Net + Tare: exact agreement		none	
14.1.4		Tare: Rounding rules		none	
14.1.5	33	Tolerance function of range		none	
14.1.6	33	Keyboard or Platter Tare: meets tolerance for net loads		none	
	7b, c, d	Capacity of ranges		none	
Direct Sale (Section 15)			(Section)		
MC Manual	MC Spec	Description	Pub. 14	Handbook 44	Description
15	22, 31	Information as required by Spec 22		none	
Non-Metrological Functions (Section 16)			(Section)		
MC Manual	MC Spec	Description	Pub. 14	Handbook 44	Description
16	29	Non-metrological functions do not cause errors, perpetration of fraud		none	

NTEP Committee 2015 Final Report
Appendix G – 2014 NTEP MDMD Work Group Meeting Summary
Sub-Appendix B – Comparison Document of MC and U.S. MDMD Requirements

Software Version Test (Section 17)			Markings (Section 1)		
MC Manual	MC Spec	Description	Pub. 14	Handbook 44	Description
17	5	Software Identification test	1.4	G-S.1.	Software markings
Performance Tests (Part 3)			Performance (Sections 7, 8, 9, 10)		
MC Manual	MC Spec	Description	Pub. 14	Handbook 44	Description
3.01	36	Short Time Power Reduction (not performed)		none	
3.02	35a,b	Power Voltage	9	T.5.2.	Power Voltage
3.03	36	Electrical Burst Test (not performed)		none	
3.04	36	Electrostatic Discharge (not performed)		none	
3.05	36	EM Susceptibility (not performed)		none	
3.06	3, 33	Warm Up	7	S.1.9.	Warm Up
3.07	3, 33	Conveyor Belt Seam		none	
3.08	3, 33	Measurement Speed Test		none	
3.09	7,8	Interval of “d”			
3.10	26,33, 35c	Temperature range	10	T.5.1.	Influence Factor
3.11	35d	Damp Heat (not performed)		none	
3.12	3, 33	Eccentricity		none	
3.13	3, 33	Drag Test		none	
3.14	33	Repeatability	8		Accuracy
3.15	3, 33	Minimum Spacing		none	
3.15.5	3, 33	Touching		none	
3.16	3, 33	Variable Orientation		none	
3.17	3, 33	Variable Object Shape		none	
3.18	3, 33	Variable Surface (only for palletized)		none	
3.19	3, 33	Protrusions (not performed)		none	
3.20	3, 33	Sensor/Emitter Obstruction		none	
3.21	35e	Radiated Light (not performed)		none	
3.22	35f	Acoustic Interference (not performed)		none	

Notes:

1) Table S.1.6 (NIST Handbook 44) and Spec. 21, 22 (MC) contain marking requirements that are not always part of an approval evaluation, as this info is sometime instead to be provided by the billing system used in conjunction with the device.

2) Sealing requirements were not included in this comparison.

THIS PAGE INTENTIONALLY LEFT BLANK

Sub-Appendix C: Illustration of Measurement Canada’s Dimensional Standards

Dimensional Standards

Materials:
NYLATRON NSM

Dimensions:

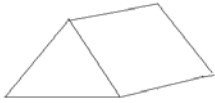

Triangular Prism 1 (L5m-A):
20 cm each side × 60 cm length

Triangular Prism 2 (L5m-B):
40 cm each side × 40 cm length

Cylinder 1 (L5m-C):
Ø 15 cm × 60 cm length

Cylinder 2 (L5m-D):
Ø 40 cm × 40 cm length

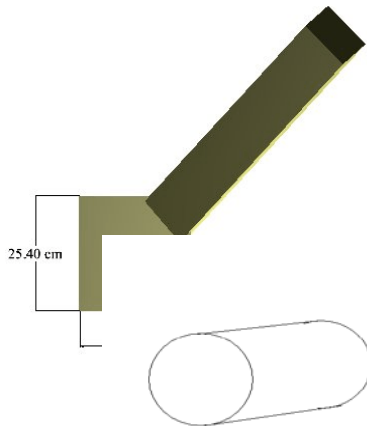

Irreg 1 (L5m-E):
Cube side = 25.4 cm
Extension = 90 cm total length from the corner
of the box to the extremity of the extension (part
of which will be inserted inside the cube) x 12
cm x 12 cm

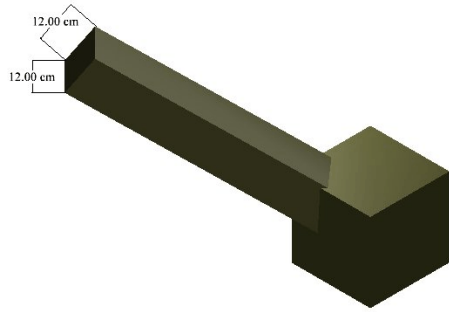

Irreg 2 (L5m-F):

Cube side = 40 cm

Extension = 130 cm total length from the corner of the box to the extremity of the extension (part of which will be inserted in the cube) x 18 cm x 18 cm

Construction:

Fabrication tolerances for each box are as follows:

linear tolerance: ± 0.5 mm (± 0.02 in)

angular tolerance: ± 0.5 mm (± 0.02 in)

Thickness of the material: 9.525 mm ($3/8$ in) to 12.7 mm ($1/2$ in), depending on the design for the construction, #6 and #8 stainless steel woods screws.

The surfaces shall be perfectly parallel and perpendicular to within the above stated tolerances.

Irreg 1 and Irreg 2 must be constructed such that they are completely stable when placed in the position indicated in the drawings above.

Maximum weight of each standard: 15 kg.

All standards to be engraved with their name.

All surfaces shall be smooth, identified with an engraved number and have their nominal dimensions engraved in millimetres.