

REVISION	DESCRIPTION	BY	DATE
0	ISSUE FOR CONSTRUCTION		09/06/13
1	PRE-BID CLARIFICATION		11/08/13

**GENERAL NOTES:**  
 1. SEE DETAILS FOR ADDITIONAL PIPING SPECIALTIES REQUIRED AT EQUIPMENT.

MECHANICAL AND ELECTRICAL ENGINEERING CONSULTANT:



MEP CONSULTANTS  
 20251 CENTURY BLVD #125  
 GERMANTOWN, MD 20874  
 P: 877-871-4229  
 F: 301-560-6366  
 JFORD@CFRENGINEERING.COM  
 PROJECT #12074

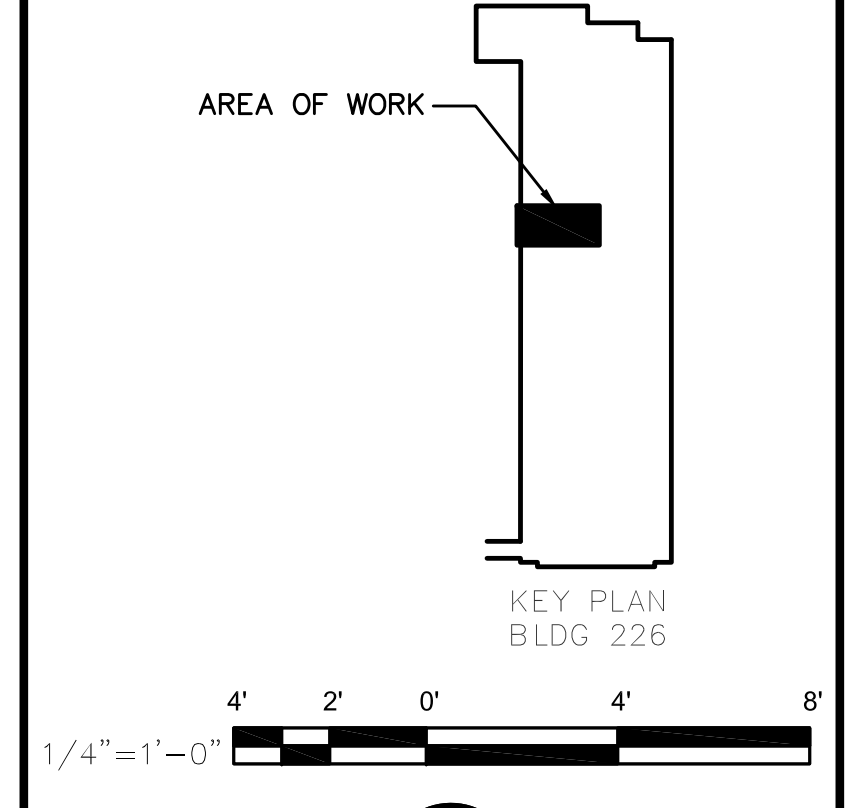
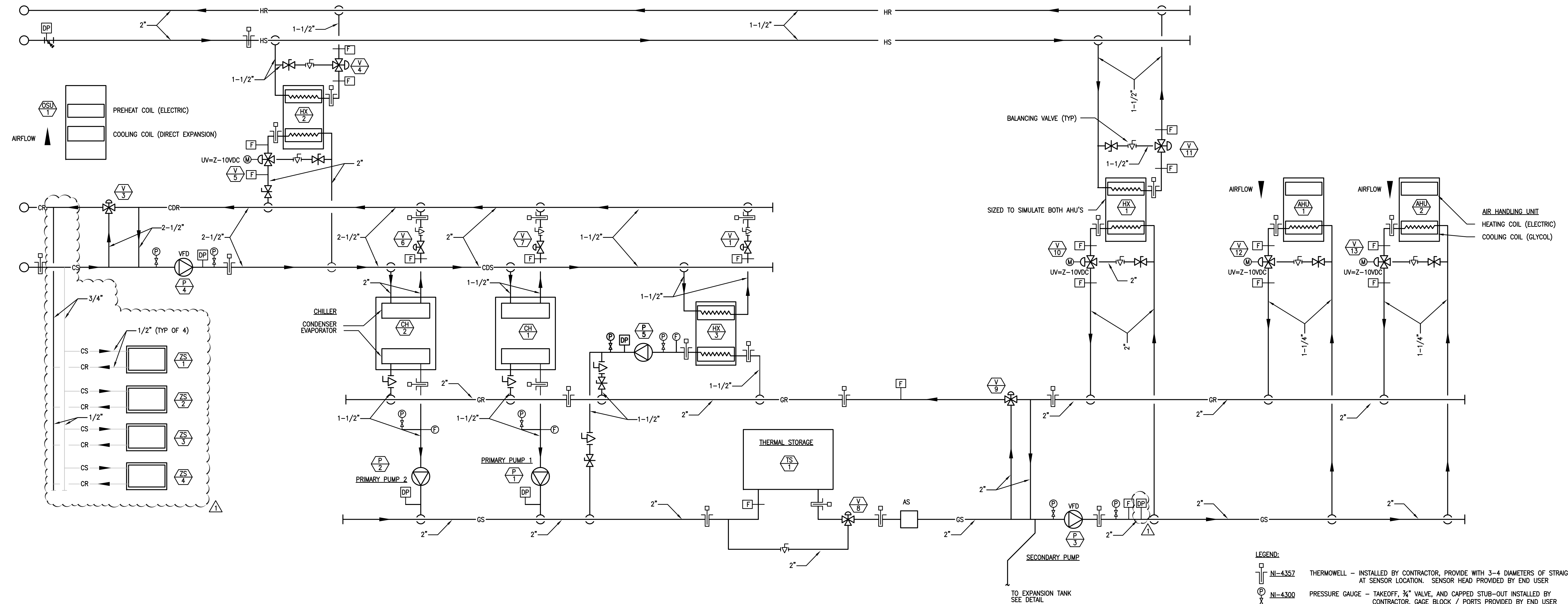
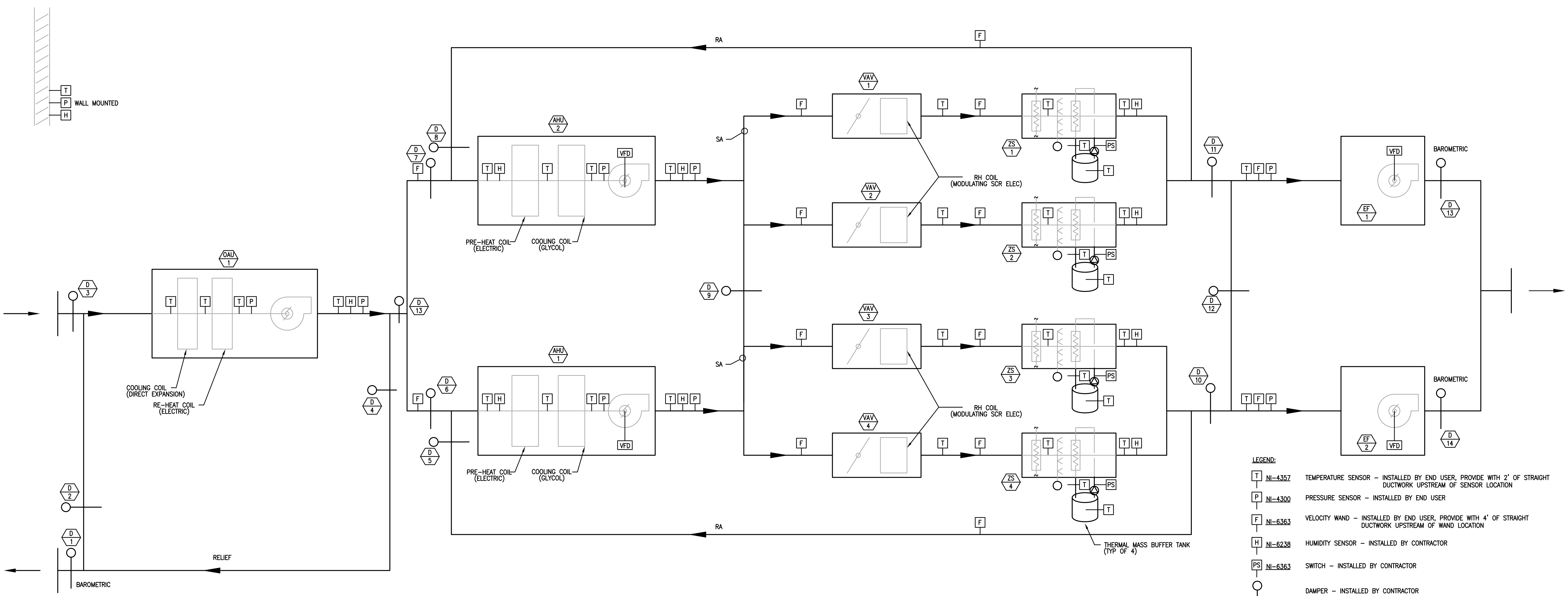

**NIST** NORTH M-12  
 U.S. DEPARTMENT OF COMMERCE  
 NATIONAL INSTITUTE OF STANDARDS AND TECHNOLOGY  
 PLANT DIVISION  
 BUILDING 226 - ROOM A122 HVAC TESTING LAB