



# Installation, Operation & Maintenance Instructions

1200°C Tube furnaces (3-zone)  
types TZF & GZF

This manual is for the guidance of operators of the above Carbolite products and should be read before the furnace is connected to the electricity supply.

---

## CONTENTS

Section		page
1.0	Introduction	2
2.0	Installation	3
3.0	Operation	5
4.0	Maintenance	8
4.0	Repairs & Replacements	9
5.0	Fault Analysis	12
6.0	Circuit Details	13
7.0	Fuses & Power Settings	16
8.0	Specifications	18

---

**Manuals are supplied separately for the furnace controllers  
(and overtemperature controller when fitted).**

Please read the controller manuals before operating the furnace.

## 1.0 INTRODUCTION

### 1.1 Products Covered

This manual contains installation and operating instructions for two types of furnace. Both types are “three-zone” furnaces designed principally to achieve a single heating zone of extended temperature uniformity.

The TZF range has heating elements comprising a ceramic work tube wound with resistance wire.

The GZF range has “modular” heating elements of resistance wire partially embedded in vacuum formed light-weight refractory fibre. The element modules are 182mm long. Usually the end elements (two only) are rated at 1500W maximum, and the centre elements (the remainder) at 1000W.

### 1.2 Switches and Lights



Supply Light: when the furnace is connected to the electrical supply the light in the adjacent switch glows



Heat Switch: the switch disconnects power to the heating elements; unless this switch is off there is a danger of electric shock when inserting objects into the furnace



Heat Light: the adjacent light glows or flashes to indicate that power is being supplied to the elements

### 1.3 Warning Symbols

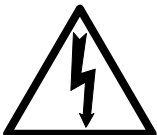

DANGER of electrical shock– read any warning printed by this symbol.



DANGER – hot surface. Read any warning printed by this symbol.  
WARNING: all surfaces of a furnace may be hot.



DANGER – read any warning printed by this symbol.

## 2.0 INSTALLATION

### 2.1 Unpacking & Handling

When unpacking or moving the furnace always lift it by its base or by both ends of the main body. Never lift it by its work tube or the surrounding insulation. For the larger models, or where the furnace and control box are not fixed together, use two people to carry the furnace.

Remove any packing material from inside the furnace before use.

NOTE: This product contains **Refractory Ceramic Fibre** (better described as **Alumino Silicate Wool**) for precautions and advice in handling this material see the 'Repairs and Replacements' section.

### 2.2 Siting

Place the furnace in a well ventilated room, away from other sources of heat, and on a surface which is resistant to accidental spillage of hot materials. Do not mount the furnace on an inflammable surface.

Ensure that there is free space around the furnace. Do not obstruct any of the vents in the control section: they are needed to keep the controls cool.

Ensure that the furnace is placed in such a way that it can be quickly switched off or disconnected from the electrical supply - see below.

### 2.3 Setting Up

A furnace ordered for vertical use has a small clip or plate at one end to prevent a wound tube element or a work tube from slipping downwards. Mount the furnace so that this clip is at the bottom. In models with one thermocouple the thermocouple should be near the top rather than the bottom.

If the furnace is supplied with a separate work tube or any accessories fit these into position.

For optimum temperature uniformity, insulating plugs should be placed in the tube ends as shown in fig.1. With a long work tube, the stem of the plug assembly should line up with the end of the tube as in fig.2. Alignment of radiation shields is similar to that of plugs.

If stainless steel seals with gas inlets are supplied they are to be fitted as shown in fig.3; the stem of any insulating plug should touch the seal. *Stainless steel seals for vertical use:* a hook and eye arrangement holds the upper insulating plug assembly; alternatively a gland nut.

*Horizontal models:* if heavy fittings are to be clamped to the end of an extended work tube they can increase the bending stress at the centre of the tube. Support such fittings in such a way that expansion of the tube is allowed.

If a metal work tube is being used in the furnace, ensure that it is earthed. In the case of wound-tube models (TZF) it should be mounted so as not to touch the furnace ceramic tube. See the safety warning in section 3.4.

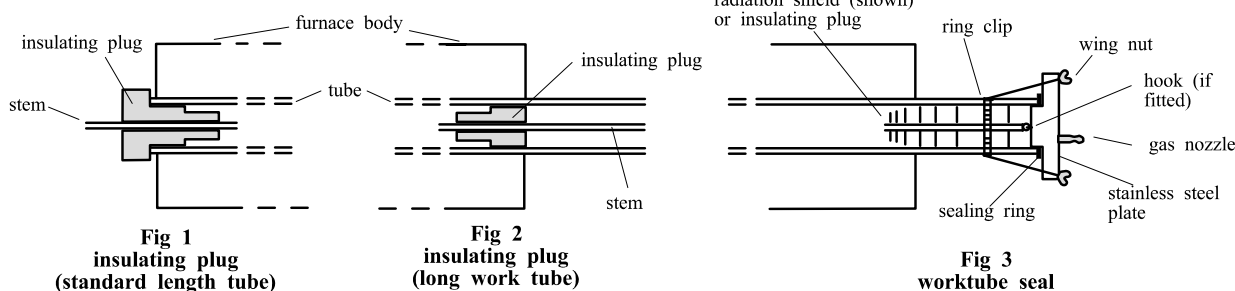

## 2.4 Electrical Connections

*Connection by a qualified electrician is recommended.*

The furnaces covered by this manual may be ordered for single phase A.C. supply, which may be Live to Neutral non-reversible, Live to Neutral reversible or Live to Live. Some models can be supplied for three phase use; some for use on two phases of a three phase with neutral supply (one phase unused).

Check the furnace rating label before connection. The supply voltage should agree with the voltage on the label, and the supply capacity should be sufficient for the amperage on the label.

The supply should be fused at the next size equal to or higher than the amperage on the label. A table of the most common fuse ratings is also given in section 7.1 of this manual. Where a supply cable is present there are internal supply fuses; customer fusing is preferred but not essential.

Furnace with supply cable: either wire directly to an isolator or fit with a line plug.

Furnace without supply cable: a permanent connection to a fused and isolated supply should be made to the internal terminals after temporary removal of the furnace back panel.

Connection by line plug: the plug should be within reach of the operator, and should be quickly removable.

Connection to isolating switch: this should operate on both conductors (single phase) or on all live conductors (three phase), and should be within reach of the operator.

The supply MUST incorporate an earth (ground).

### CONNECTION DETAILS

Supply	Terminal label	Cable colour	<i>supply type</i>	
			<i>Live-Neutral</i>	<i>Reversible or Live-Live</i>
<b>1-phase</b>	L	Brown	To live	to either power conductor
	N	Blue	To neutral	to the other power conductor
	PE	Green/Yellow	To earth (ground)	to earth (ground)
<b>supply</b>	<b>Terminal label</b>	<b>Cable colour</b>		
<b>2- or 3-phase</b>	L1	Black	to phase 1	
	L2	Black	to phase 2	
	L3	Black	to phase 3 <i>except 2-phase</i>	
	N	Light Blue	to neutral <i>except delta</i>	
	PE	Green/Yellow	to earth (ground)	

## 2.5 “Universal Wiring”

*From Year 2000, applicable to GZF models which are available as three-phase.*

These models, when ordered for 3-phase supply, are supplied in a form in which they can be easily rewired between 1-phase and 3-phase supplies. This applies to 3-phase+N and 3-phase delta in the ranges 380/220V–415/240V and 208-240V, but does not apply to 3-phase star without neutral (e.g 380V).

To alter the configuration, remove the back panel and alter the wiring connections between the supply terminal block and the EMC filters, using the appropriate diagram from section 6.7.

Models ordered for single phase only are not affected and cannot be converted to 3-phase.

If in doubt, please consult Carbolite.

### 3.0 OPERATION

The instructions for operating the temperature controller are given in a separate manual.

If the furnace is fitted with a time switch, see also the supplementary manual MS03.

If cascade control is fitted, see the supplementary manual MS07.

#### 3.1 3-zone Control Methods

The models in this manual are typically designed to achieve an extended uniform temperature zone by the use of three control zones. The control zones are typically linked so that they all follow the central controller in a master-slave approach; there are two ways of doing this. Alternatively independent control zones may be ordered. There are thus three control methods (A, B & C).

##### A. Back-to-Back Thermocouples

This is the most commonly supplied option.

The central zone of the work tube is controlled directly by the central temperature controller. Each end zone thermocouple is wired in opposition to a central reference thermocouple, and the small voltage resulting when the zones are at different temperatures is used by the end zone controller. The circuit diagram in section 6.1 shown the thermocouple arrangement.

Set the "setpoint" of the end zone controllers to zero. Alternatively, a small temperature difference (offset) can be created by setting a non-zero value, but the sum of the main controller set-point and the slave controller offset **MUST NOT** exceed the furnace maximum temperature. The "measured temperature" display shows the actual offset.

To alter the setpoint (with the display at "home"), press Down ▼ or Up ▲ once to display the setpoint; press again or hold down to adjust it. The display returns to the measured temperature offset when no key is pressed for 0.5 seconds.

Sometimes a furnace using this type of control does not cool down: the end controllers try to remain at the central temperature. Should this occur, contact Carbolite's technical department.

##### 2132 Slave Controller Navigation Diagram

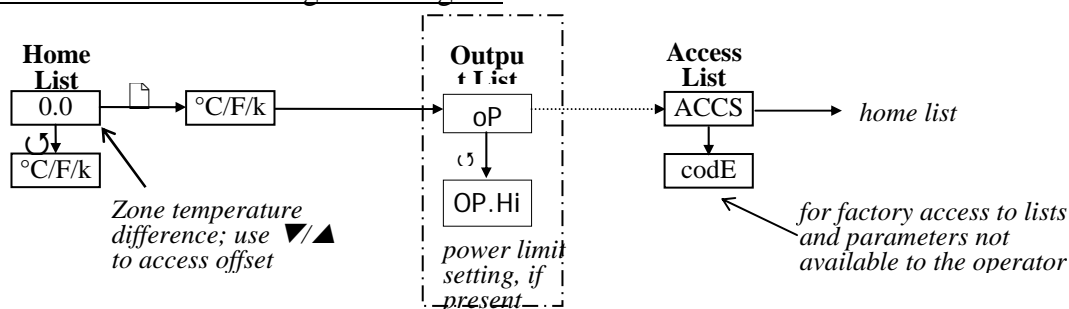

##### B. Retransmission of Setpoint using Broadcast comms

When this is ordered there are three independent thermocouples connected to the three controllers. The controllers are linked together, the central controller communicating the desired setpoint to the end controllers.

Additional communication modules are fitted in the controllers, rather than an additional thermocouple as in A. The communication between the controllers of the Eurotherm 3000 series is known as Broadcast comms.

It is possible to switch off the linked control and allow the controllers to work independently. In level 2 of the end zone controllers (see controller operating instruction), scroll to L-r. Where the end zone controller is a 3216 use the ▲ up ▼ down and select NO. Where the end zone controller is a 3508 use the ▲ up ▼ down to select SP1, (SP1 = Local, and SP2 = Remote). There is no need to alter the centre controller.

It is possible to use local trim in the end zone controllers to enter a positive or negative adjustment from the centre zone temperature. Once entered this trim will always be added or subtracted from the retransmitted set temperature. In level 2 of the end zone controller (see controller operating instruction), scroll to LOC.T (local trim) and use the ▲ up ▼ down enter the desired positive or negative difference to be added to the end zone set temperature. There is no need to alter the centre controller.

### C. Independent Control

In this case the three controllers are completely independent. Note that it is not possible to maintain very different zone temperatures because of heat transfer within the work tube.

## 3.2 Operating Cycle

The furnace is fitted with a combined Supply light and Instrument switch. The light is on whenever the furnace is connected to the supply. The switch cuts off power to the controller(s) and contactor (when fitted). There is also a Heater switch which can be used to disconnect power to the elements.

Connect the furnace to the electrical supply. The Supply light should glow.

Operate the instrument switch to activate the temperature controller. The controller becomes illuminated and goes through a short test cycle.

*Control methods A & B:* Set the slave (end zone) controllers to the desired offset temperature, usually zero. Set the main (central) temperature controller to the desired setpoint or program. See section 3.1 and/or the separate manual(s) for the controller(s).

*Control method C:* Set the three controllers to the desired temperatures. See the separate manual(s) for the controller(s).

*Overtemperature option only.* If the overtemperature controller has not yet been set as required, set it and activate it according to the instructions in the appropriate manual.

Switch on the Heater switch, located on the instrument panel. Unless a time switch is fitted and is off, the furnace starts to heat up. The Heat light(s) glow steadily at first and then flash as the furnace approaches the desired temperature or a program setpoint.

*Overtemperature option only.* If the overtemperature trip operates then an indicator in the overtemperature controller flashes, and the heating elements are isolated. Find and correct the cause before resetting the overtemperature controller according the instructions supplied.

To switch off power to the heating elements, use the Heater Switch. To switch the furnace off, use both the Heater switch and the Instrument switch. If the furnace is to be left off unattended, isolate it from the electrical supply.

## 3.3 General Operating Advice

Heating element life is shortened by use at temperatures close to maximum. Do not leave the furnace at high temperature when not required. The maximum temperature is shown on the furnace rating label and on the back page of this manual.

## 3.4 Operator Safety



The ceramic materials used in furnace manufacture become electrically conductive to some extent at high temperatures. In the GZF models there are partially exposed heating coils in the chamber. DO NOT use any conductive tools within the work tube without isolating it. If a metal work tube is used, it must be earthed (grounded).



Switch off the Heater switch whenever loading or unloading the furnace. The elements are isolated when the Heater switch is OFF. This switch cuts both sides of the circuit directly or via a contactor (a contactor is used in models where the rated current exceeds 16 Amps).

### 3.5 Tube Life

A ceramic work tube may be cracked if workpieces are inserted too quickly or at temperatures below 900°C (when the tube is more brittle). Large pieces should also be heated slowly to ensure that large temperature differences do not arise.

Poor thermal contact should be encouraged between the workpiece and the tube; crucibles or boats should be of low thermal mass and should have feet to reduce the contact with the tube (fig. 4).

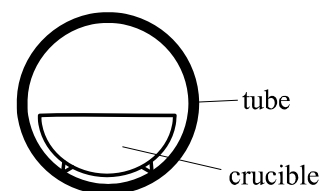

**Fig 4**  
**avoidance of thermal contact**

Do not set too high a heating rate. Large diameter tubes are more susceptible to thermal shock than smaller. Tubes which extend beyond the heated part of the furnace are more at risk. A general rule for maximum heating rate is 400/internal diameter (°C/min); for 75mm i/d tubes this comes to 5°C per minute. The controller can be set to limit the heating rate.

### 3.6 Pressure

Work tubes are not able to accept high internal pressure. When gas seals or similar fittings are in use, the gas pressure should be restricted to a maximum of 0.2 bar (3 psi). A pressure of about half of that should normally be sufficient to achieve the desired flow rate. The customer must ensure that the exhaust path from the tube is not blocked, so that excess pressure does not occur.

### 3.7 Power Adjustment

The furnace control system incorporates electronic power limiting. The power limit parameter OP.Hi is accessible to the operator, and can be used to adjust the furnace to the actual supply voltage.

*Note that any power limit applies to all three controllers.*







Some models covered by this manual are fitted with 208V elements and are designed for use over the range of voltages 200V-250; the power limit parameter is set accordingly. These models may be relocated to a different voltage within the range: the power limit should be reset to match the voltage. See section 7.2.

To check whether the furnace is a 208V model:

- look at the OP.Hi parameter – make a note of the value and compare with section 7.2;
- observe the rating label; if a range of voltages is stated, it is not a 208V multivoltage model;
- if in doubt, check with Carbolite – each product has its own record card.

To alter the power limit

Set the Heater Switch to Off to prevent heating while adjusting the power limit.

Press Page  until oP (output list) is displayed. Press Scroll  until OP.Hi (Output High) is displayed. Press Down  or Up  once to display the value of OP.Hi (it is good practice to write down the original value). To alter the parameter to the desired value use Down  or Up .

A power setting of zero prevents the furnace from heating: useful for demonstrating the controls without taking power.

Do not increase the power limit simply “to get more power”. The elements could burn out, or a fuse could blow.

### 3.8 Running at Low Temperatures

The power limit may be adjusted to a low level to achieve better control when running the furnace at a low temperature. No hard and fast rules can be given, but, as an example, to run at temperatures only up to 600°C try a power limit of 50%. Control stability may fall off again if a setting below about 40% is used.

Before changing the power limit, record its factory setting for possible future use.

## **MAINTENANCE**

### **3.9 General Maintenance**

No routine maintenance is required. The outer surfaces may be cleaned with a damp cloth. Do not allow water to enter the interior of the case, tube or control box. Do not clean with organic solvents.

### **3.10 Calibration**

After prolonged use the controller and/or thermocouple could require recalibration. This would be important for processes which require accurate temperature readings or which use the furnace close to its maximum temperature. A quick check using an independent thermocouple and temperature indicator should be made from time to time to determine whether full calibration is required. These items can be supplied by Carbolite.

Depending on the controller, the controller manual may contain calibration instructions.

### **3.11 After Sales Service**

Carbolite's service division (Thermal Engineering Services) has a team of Service Engineers capable of repair, calibration and preventive maintenance of furnace and oven products at our customers' premises throughout the world. We also sell spares by mail order. A telephone call or fax often enables a fault to be diagnosed and the necessary spare part despatched.

Each furnace has its own record card at Carbolite. In all correspondence please quote the serial number, model type and voltage given on the rating label of the furnace. The serial number and model type are also given on the front of this booklet when supplied with a furnace.

To contact Thermal Engineering Services or Carbolite see the back page of this manual.

### **3.12 Recommended Spares Kits**

Carbolite can supply individual spares, or a kit of the items most likely to be required. Ordering a kit in advance can save time in the event of a breakdown. Each kit comprises one of each type of thermocouple, one solid state relay, and one heating element (GZF: 2 elements, one of each wattage).

When ordering spares please quote the model details as requested above.



## 4.0 REPAIRS & REPLACEMENTS

### 4.1 Safety Warning – Disconnection from Supply

Always ensure that the furnace is disconnected from the supply before repair work is carried out.

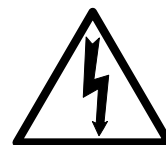

### 4.2 Safety Warning - Refractory Fibrous Insulation

**Insulation made from High Temperature Insulation Wool**

**Refractory Ceramic Fibre, (better described as Alumino Silicate Wool) (ASW)**

This product contains **alumino silicate wool products** in its thermal insulation. These materials may be in the form of blanket or felt, formed board or shapes, mineral wool slab or loose fill wool.

Whilst there is no evidence of any long term health hazards, we strongly recommend that safety precautions are taken whenever the materials are handled.

**Exposure to fibrous dust may cause respiratory disease.**

**When handling the material always use an approved respiratory protection equipment (RPE-i.e. FFP3), eye protection, gloves and long sleeved clothing.**

**Avoid breaking up waste material. Dispose of waste in sealed containers.**

**After handling rinse exposed skin with water before washing gently with soap (not detergent). Wash work clothing separately.**



Before commencing any major repairs we recommend reference to the European Association representing the High Temperature Insulation Wool industry ([www.ecfia.eu](http://www.ecfia.eu))

We can provide further information on request. Alternatively our service division can quote for any repairs to be carried out at your premises or ours.

### 4.3 Temperature Controller Replacement

201. This controller is fitted to the back of the control panel; in many models this can be separated from the base by removal of two screws.



Before handling the controller: **wear an anti-static wrist strap** or otherwise avoid any possibility of damage to the unit by static electricity.

Refer to the detailed instructions supplied with the replacement controller.

2000 & 3000 series. Ease apart the two lugs at the side; grip the instrument and withdraw it from its sleeve; push in the replacement.

### 4.4 Solid-state Relay Replacement

Disconnect the furnace from the supply and remove the back panel from the base or control box..

Make a note of how the wires are connected to the solid state relay, and disconnect them.

Remove the solid state relay from the base panel or aluminium plate.

Replace and reconnect the solid state relay ensuring that the heat-conducting thermal pad is sandwiched between the relay and the base panel or aluminium plate. Alternatively a thin layer of white, heat-conducting silicon paste may be applied between the new relay and the plate.

Replace the removed panel.

#### 4.5 Thermocouple Replacement

The coverings and guards which must be removed to gain access to the thermocouple depend on the model, its orientation (horizontal or vertical), and possibly other options and fittings. It is usually necessary to separate the furnace from its base or stand. On horizontal models (except TZF 12/38) one outer end-cap should be removed; on TZF 12/38 and vertical models the terminal cover.

Disconnect the furnace from the supply, and separate the furnace body and/or remove covers and guards as necessary.

Make a note of the thermocouple connections. Type N colour codings are:

current models	<i>negative</i> : white	<i>positive (type K)</i> : green	<i>positive (type N)</i> : pink
old models	<i>negative</i> : blue	<i>positive (type K)</i> : white	<i>positive (type N)</i> : orange

Disconnect the thermocouple from its terminal blocks.

Withdraw the thermocouple from its sheath and remove any broken bits of thermocouple.

Bend the new thermocouple carefully to match the shape of the original (working from the terminal end). Should the length differ from that of the original this is usually not important provided that the thermocouple tip is within a tube diameter's distance from the furnace centre.

Insert the new thermocouple into position, restoring any removed porcelain spacers, and ensuring correct polarity.

Re-assemble the furnace.

#### 4.6 Element Replacement



*Please see safety note 4.2 - please wear a face mask.*

The coverings and guards which must be removed to enable replacement of the wound tube element depend on the furnace model, its orientation (horizontal or vertical), and other options and fittings. The general procedure is:

Disconnect the furnace from the electrical supply.

Remove all outer guards, meshes and terminal covers from the furnace body. For a horizontally mounted furnace remove the furnace body from its base; to reach the bolts or screws which fix the body to the base, remove the back panel from the base.

Disconnect all electrical leads from the terminal blocks on the furnace case. Note the colours and positions of the connecting leads to enable correct reassembly. Take care not to crack porcelain terminal blocks - use two spanners where appropriate.

Remove the thermocouples.

Lay the furnace body horizontally with the split in the cylindrical case uppermost. Remove the two metal end-caps from the body. Except TZF 12/38, undo the self-tapping screws which hold the terminal strip to the case join. The case should spring open slightly. Remove the ceramic board disc from one end.

*TZF*: Use a sharp knife to cut right through the insulation down to the wire-wound tube element along the whole length of the body, but do not cut either of the ceramic board end discs. The knife cut must be in line with the element lead wires. Slide the element gently out through the end of the furnace body.

*GZF*: Cut through the outer wrap of blanket insulation. Note how the element tails are connected and disconnect all of them. Lift out the elements through the end of the cylindrical case.

##### Note on GZF Elements

The end and centre elements of GZF models look the same but have different wattages. The two end elements are 1500W, and all the centre elements are 1000W. Ensure that elements are correctly replaced.

Check the cylindrical case and clean out as appropriate.

Remove any insulation sleeving from the tails of the old element and fit to the replacement element.

Slide in the new element(s). Close up the furnace again, refitting the terminal strip (where applicable) and the end-caps. Any cut made in the insulation should close up completely: if the insulation appears loose or damaged in any way, please contact our service division.

Reverse the rest of the disassembly process. Take care to make all connections to the correct terminals. Do not overtighten the connectors in porcelain terminal blocks.

Let the furnace heat up at its maximum rate to 900°C without interruption, and then soak for 1 hour. Fumes may be emitted: this should be done in conditions of good ventilation.

Check that the furnace is controlling properly to rule out the possibility that the element failed because of a fault in the control system.

If you have any problems with this procedure, please contact our service division.

#### **4.7 Fuse Replacement**

Fuses are marked on the circuit diagram (section 6.1) with type codes, e.g. F1, F2. A list of the correct fuses is given in section 7.1. *Depending on model and voltage, the different fuse types may or may not be fitted.*

If any fuse has failed, it is advisable for an electrician to check the internal circuits.

Replace any failed fuses with the correct type. For safety reasons do not fit larger capacity fuses without first consulting Carbolite.

The fuses are near the cable entry point, and access is by removal of the back panel of the base or control box.

## 5.0 FAULT ANALYSIS

### A. Furnace Does Not Heat Up

- |    |                                     |  |   |
|----|-------------------------------------|--|---|
| 1. | The <b>HEAT</b> light is <b>ON</b>  | → The heating element has failed   | → Check also that the SSR is working correctly  |
| 2. | The <b>HEAT</b> light is <b>OFF</b> | The controller shows a <b>very high temperature</b> or a code such as S.br | → The thermocouple has broken or has a wiring fault   |
|    |                                     | The controller shows a <b>low temperature</b>                              | → The door switch(es) (if fitted) may be faulty or need adjustment<br>→ The contactor (if fitted) may be faulty<br>→ The SSR could be failing to switch on due to internal failure, faulty logic wiring from the controller, or faulty controller             |
|    |                                     | There are no lights glowing on the controller                              | → The <b>SUPPLY</b> light is <b>ON</b> → The controller may be faulty or not receiving a supply due to a faulty switch or a wiring fault<br>→ The <b>SUPPLY</b> light is <b>OFF</b> → Check the supply fuses and any fuses in the furnace control compartment |

### B. Furnace Overheats

- |    |   |   |   |
|----|---|---|---|
| 1. | The <b>HEAT</b> light goes <b>OFF</b> with the instrument switch        | → The controller shows a <b>very high</b> temperature | → The controller is faulty  |
|    |   | → The controller shows a <b>low</b> temperature       | → The thermocouple may have been shorted out or may have been moved out of the heating chamber<br>→ The thermocouple may be mounted the wrong way round<br>→ The controller may be faulty |
| 2. | The <b>HEAT</b> light <b>does not go off</b> with the instrument switch | → The SSR has failed "ON"                             | → Check for an accidental wiring fault which could have overloaded the SSR  |

## 6.0 CIRCUIT DETAILS

Safety Switches type A: a 2-pole Heater Switch is fitted directly in the element circuit in models up to 16A rating.

Safety Switch type B: a Heater Switch is fitted into the contactor coil circuit in models over 16A.

### 6.1 Single Phase (example for TZF, control method A)

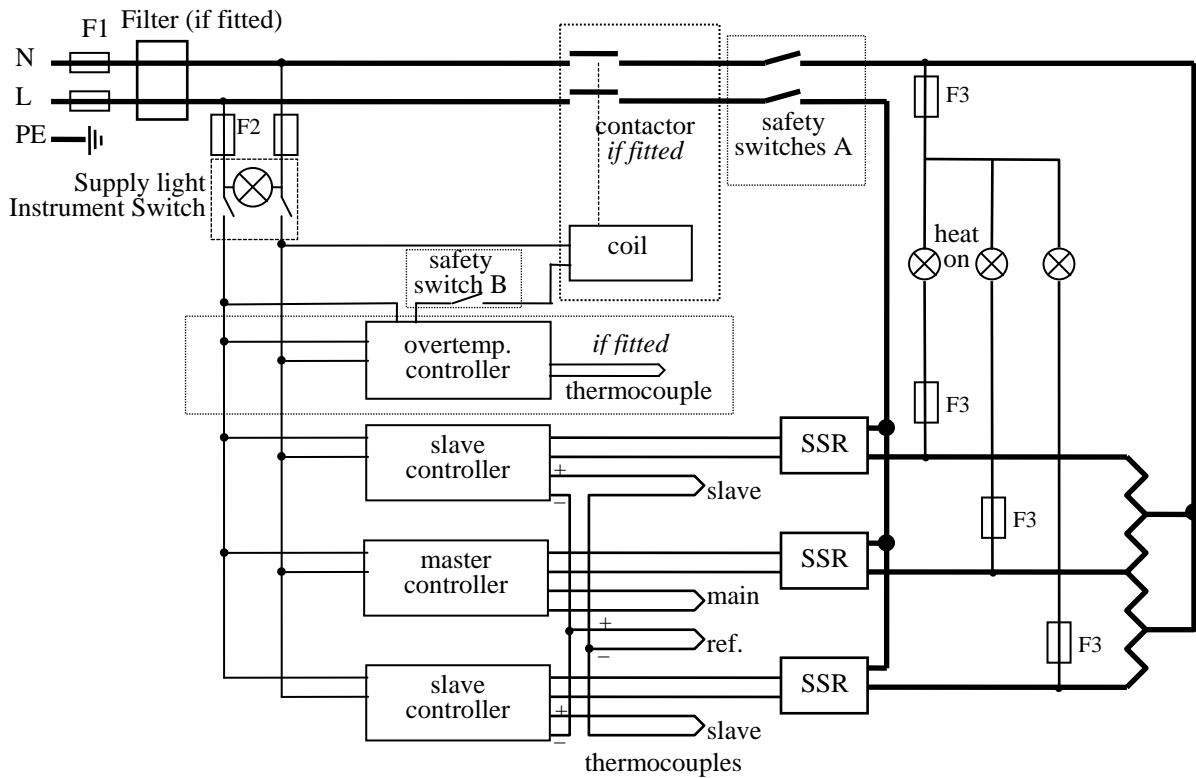

### 6.2 2- or 3-Phase

See also section 6.7. for certain models.

Each SSR is connected to a different phase. The control circuit is taken between L1 and N.

Safety switch A applies for 2-phase. Safety switch B applies for 3-phase.

If type F1 fuse is present, one per phase if fitted. If type F2 fuse is present, one is fitted; if type F3 fuse is present, one per phase is fitted.

Note that on 2- or 3-phase models there may be three separate neutrals taken to a common supply terminal, depending on EMC filter requirements.

### 6.3 Higher Voltages

For 254V or above (or 440V, 3-phase) an isolating transformer is fitted in the control circuit after the F2 fuses.

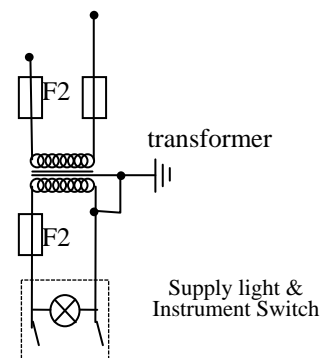

**6.4 Independent Zones (control method C)**

When this is ordered there are three independent thermocouples (instead of the four shown) connected to the three controllers; the words “master” and “slave” may be replaced by “centre” and “end”.

**6.5 Control by Broadcast comms (control method B)**

When this is ordered there are three independent thermocouples (instead of the four shown) connected to the three controllers; the controllers are linked together (not shown), and remain “master” and “slave”.

The communication between the controllers of the Eurotherm 3000 series is known as Broadcast comms. The wiring connections between the controllers are as follows:

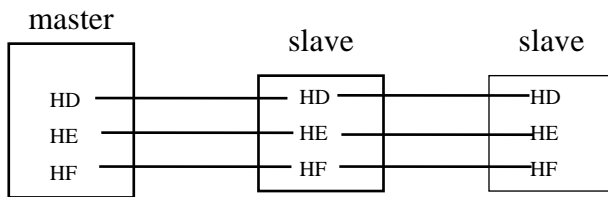

**6.6 GZF Models**

These models normally have end zones of one element each; the centre zone comprises the remaining elements wired in parallel.

For the “equal zone” models (suffix E) the zones are as equal as possible: in GZF 12/1092 the zones are each 2 element modules each.

Note that a 3-phase GZF 12/1092 may have 4 x SSR; in this case phase 1 is for the end zones (2 x SSR); phases 2 & 3 are for the centre zone (2 elements per SSR).

There are many possible electrical configurations for GZF models covering 1- 2- or 3-phase, including 3-phase delta. 3-phase GZFs are made with “universal” wiring as explained in sections 2.5 and 6.7.

6.7 **3-phase “universal” wiring**

Applicable to certain models only: see section 2.5

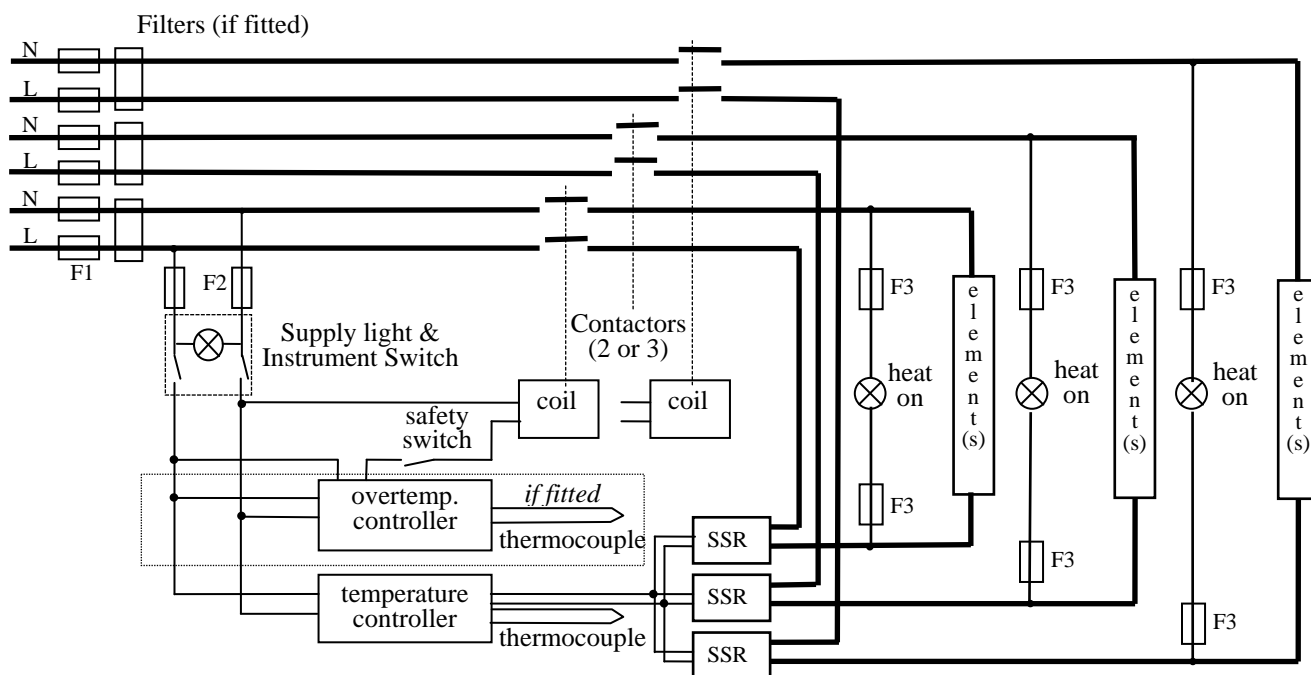

Fuses F1 are always present in this wiring design.  
 Fuses F2 could be absent in some circumstances, if the circuit does not exceed 10A.  
 Fuses F3 are present if the circuit exceeds 25A, but otherwise are usually absent.

**3-phase + neutral**

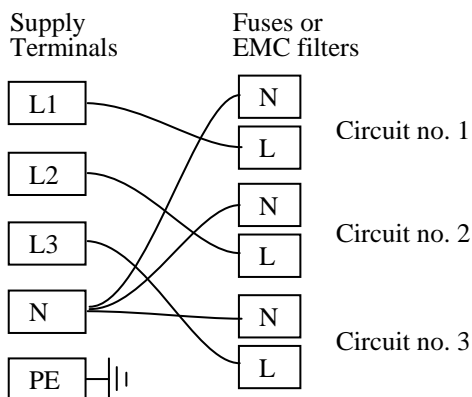

**3-phase delta**

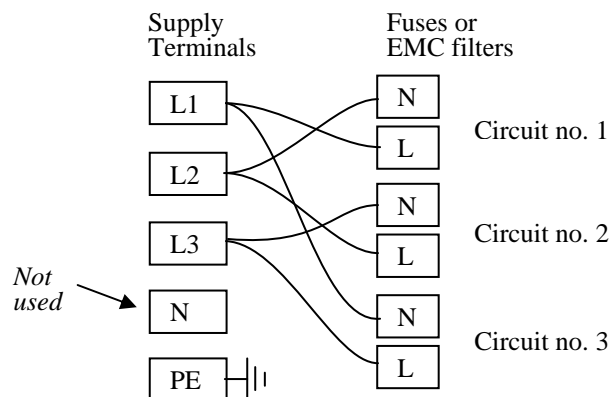

**1-phase**

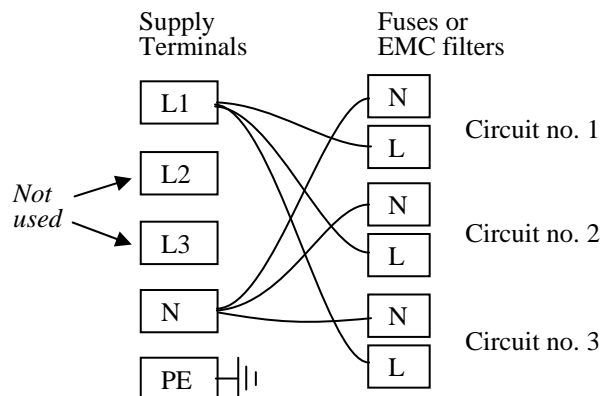

A model made to this diagram can be converted by the customer between the following supply voltages:

*between 3-phase + neutral in the range 380/220V – 415/240V*

*and 3-phase delta in the range 220V – 240V*

*and single phase in the range 220V – 240V*

*208V model: convertible from 208V delta to 208V 1-phase*

## 7.0 FUSES & POWER SETTINGS

### 7.1 Fuses

*F1-F3: refer to the example circuit diagram.*

<i>F1</i>	Internal supply fuses	Fitted if supply cable fitted. Fitted on board to some types of EMC filter.	on-board and up to 16 Amps: 32mm x 6mm type F other: GEC Safeclip
<i>F2</i>	Auxiliary circuit fuses	Fitted on board to some types of EMC filter. May be omitted up to 25Amp/phase supply rating.	2 Amps glass type F On board: 20mm x 5mm Other: 32mm x 6mm
<i>F3</i>	Heat Light fuses	May be omitted up to 25 Amp/phase supply rating.	2 Amps glass type F 32mm x 6mm
	<b>Customer fuses</b>	Required if no supply cable fitted. Recommended if cable fitted.	See rating label for amperage; see table below for fuse rating.

Access to internal fuses is by removal of the back panel of the furnace base or control box.

Model	phases	Volts	Supply Rating	Volts	Supply Rating
TZF 12/38/400	1-phase	200-240	7A	110-120	12.5A
TZF 12/65/550	1-phase	200-240	10A	110-120	20A
TZF 12/65/550	2- or 3-phase + N	380/220 - 415/240	5A		
TZF 12/75/700	1-phase	220-240	12.5A	110-120	25A
TZF 12/75/700	1-phase	208	15-16A	100	30-32A
TZF 12/75/700	2- or 3-phase + N	380/220 - 415/240	7A		
TZF 12/100/900	1-phase	200-240	20A	110-120	40A
TZF 12/100/900	2- or 3-phase + N	380/220 - 415/240	15-16A		
GZF 12/546	1-phase	200-240	20A		
GZF 12/546	3-phase + N	380/220 - 415/240	10A	220-240 delta	12.5A
GZF 12/728	1-phase	200-240	25A		
GZF 12/728	2-phase + N	380/220 - 415/240	12.5A		
GZF 12/728	3-phase + N	380/220 - 415/240	10A	220-240 delta	12.5A
GZF 12/910	1-phase	200-240	25A		
GZF 12/910	2-phase + N	380/220 - 415/240	12.5A		
GZF 12/910	3-phase	380/220 - 415/240	12.5A	220-240 delta	20A
GZF 12/1092	1-phase	200-240	30-32A		
GZF 12/1092	2-phase + N	380/220 - 415/240	15-16A		
GZF 12/1092	3-phase	380/220 - 415/240	12.5A	220-240 delta	20A

*other models or voltages: check the rating label for details of the supply.*



## 7.2 Power Settings

The models covered by this manual are designed to run on 100% power, with the exceptions below.

Model Volts:	200V	208V	220V	230V	240V	380V	400V	415V
Equal zone models: TZF 12/38/400E TZF 12/65/550E	100	100	89	82	75	-	-	-
Custom Models: TZF 12/25/550 TZF 12/38/550 TZF 12/75/550 TZF 12/75/900	100	100	89	82	75	-	-	-
Standard Model: TZF 12/100/900 (from April 2000)	100	100	89	82	75	89	82	75

### 208V Models

Models may be supplied to the USA market with 208V elements, and use power limit if connected to higher voltages, as follows:

Model Volts:	200V	208V	220V	230V	240V	380V	400V	415V
all GZF 208V models	100	100	89	82	75	89	82	75

### Other possible exceptions:

Further custom furnaces based on the standard models may be designed with power limits other than 100%.

Furnaces supplied for use on 254 Volt typically have a power setting of 89% of the limit for the corresponding 240V model.

## 8.0 SPECIFICATIONS

*Carbolite reserves the right to change specifications without notice.*

### 8.1 Models Covered by this Manual

MODEL	Max. Temp. (°C)	Max. Power (kW)	Work Tube Bore (mm)	Work Tube Length (mm)	Heated Length (mm)	Uniform Zone Length <sup>1</sup> (mm)	Net Weight <sup>2</sup> (kg)
<i>Tube furnaces with a ceramic work tube wound with resistance wire</i>							
TZF 12/38/400	1200°C	1.5	38	450	400	305	15
TZF 12/65/550	1200°C	2.0	65	600	550	392	25
TZF 12/75/700	1200°C	3.0	75	750	700	510	28
TZF 12/100/900	1200°C	4.5	100	950	900	745	35
<i>Tube furnaces with modular vacuum formed elements with embedded resistance wire</i>							
GZF 12/546	1200°C	4	170max	750/1200 <sup>(3)</sup>	546		45
GZF 12/728	1200°C	5	170max	900/1400 <sup>(3)</sup>	728		50
GZF 12/910	1200°C	6	170max	1100/1600 <sup>(3)</sup>	910		55
GZF 12/1092	1200°C	7	170max	1300/1800 <sup>(3)</sup>	1092		60
<i>also models based on the above, but of other diameters or lengths, supplied to special order</i>							

note 1: The figures for uniform zone length are for  $\pm 5^{\circ}\text{C}$  and are based on measurements with the furnace horizontal and fitted with insulating plugs in both tube ends. They assume the use of master-slave control.

note 2: Weights are approximate for horizontal models and do not include fittings or vertical stands.

note 3: GZF tubes: recommended lengths for type C / D tubes are shown (C = no fittings; D = long enough for gas fittings etc.).

### 8.2 Environment

The furnaces contain electrical parts and should be stored and used in indoor conditions as follows:

temperature:  $5^{\circ}\text{C} - 40^{\circ}\text{C}$

relative humidity: maximum 80% up to  $31^{\circ}\text{C}$  decreasing linearly to 50% at  $40^{\circ}\text{C}$



The products covered in this manual are only a small part of the wide range of ovens, chamber furnaces and tube furnaces manufactured by Carbolite for laboratory and industrial use. For further details of our standard or custom built products please contact us at the address below, or ask your nearest stockist.

*For preventive maintenance, repair and calibration of all Furnace and Oven products, please contact:*

**Thermal Engineering Services**

**Telephone:** UK: 0845 3308035      Int: +44 1433 623335  
**Fax:** UK: 0845 3308036      Int: +44 1433 623336  
**Email:** [service@thermalserve.com](mailto:service@thermalserve.com)



MF12-3.11

11/01/12

TZF/GZF

Carbolite, Parsons Lane, Hope,  
Hope Valley, S33 6RB, England.

**Telephone:** (01433) 620011  
Int: +44 1433 620011

**Facsimile:** (01433) 621198  
Int: +44 1433 621198

**E-mail:** [info@carbolite.com](mailto:info@carbolite.com)