

NBS MISC. PUBL. 260-7

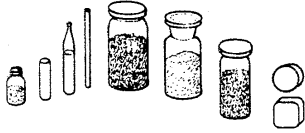

Standard Reference Materials:

**METHODS FOR THE CHEMICAL ANALYSIS OF
NBS COPPER-BASE SPECTROCHEMICAL
STANDARDS**

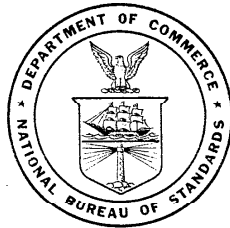

**U.S. Department of Commerce
National Bureau of Standards**

THE NATIONAL BUREAU OF STANDARDS

The National Bureau of Standards is a principal focal point in the Federal Government for assuring maximum application of the physical and engineering sciences to the advancement of technology in industry and commerce. Its responsibilities include development and maintenance of the national standards of measurement, and the provisions of means for making measurements consistent with those standards; determination of physical constants and properties of materials; development of methods for testing materials, mechanisms, and structures, and making such tests as may be necessary, particularly for government agencies; cooperation in the establishment of standard practices for incorporation in codes and specifications; advisory service to government agencies on scientific and technical problems; invention and development of devices to serve special needs of the Government; assistance to industry, business, and consumers in the development and acceptance of commercial standards and simplified trade practice recommendations; administration of programs in cooperation with United States business groups and standards organizations for the development of international standards of practice; and maintenance of a clearinghouse for the collection and dissemination of scientific, technical, and engineering information. The scope of the Bureau's activities is suggested in the following listing of its four Institutes and their organizational units.

Institute for Basic Standards. Applied Mathematics. Electricity. Metrology. Mechanics. Heat. Atomic Physics. Physical Chemistry. Laboratory Astrophysics.* Radiation Physics. Radio Standards Laboratory.* Radio Standards Physics; Radio Standards Engineering. Office of Standard Reference Data.

Institute for Materials Research. Analytical Chemistry. Polymers. Metallurgy. Inorganic Materials. Reactor Radiations. Cryogenics.* Materials Evaluation Laboratory. Office of Standard Reference Materials.

Institute for Applied Technology. Building Research. Information Technology. Performance Test Development. Electronic Instrumentation. Textile and Apparel Technology Center. Technical Analysis. Office of Weights and Measures. Office of Engineering Standards. Office of Invention and Innovation. Office of Technical Resources. Clearinghouse for Federal Scientific and Technical Information.**

Central Radio Propagation Laboratory.* Ionospheric Telecommunications. Tropospheric Telecommunications. Space Environment Forecasting. Aeronomy.

* Located at Boulder, Colorado 80301.

** Located at 5285 Port Royal Road, Springfield, Virginia 22171.

UNITED STATES DEPARTMENT OF COMMERCE • John T. Connor, *Secretary*
NATIONAL BUREAU OF STANDARDS • A. V. Astin, *Director*

Standard Reference Materials:

Methods for the Chemical Analysis of NBS Copper-Base Spectrochemical Standards

Rosemond K. Bell

**Institute for Material Research
National Bureau of Standards
Washington, D.C.**



National Bureau of Standards Miscellaneous Publication 260-7

Issued October 25, 1965

For sale by the Superintendent of Documents, U.S. Government Printing Office
Washington, D.C., 20402 - Price 60 cents

PREFACE

Within the framework of the NBS Institute for Materials Research the area of standard reference materials is a broad and important one, including the preparation, characterization and distribution of a wide variety of materials in such diverse fields as metallurgy, polymers and inorganic materials. In carrying out such a program there is much interaction with representatives of industry and science, beginning with discussions as to which primary standard materials will do most to advance technology, the furnishing of materials and fabrication of samples, and the characterization and certification of the materials by cooperative efforts. The many groups participating in a standards program are very interested in detailed information on specific aspects of the program -- but to date there has been no publication outlet for such written discussions.

To meet this need, NBS Miscellaneous Publication 260 has been reserved for a series of papers in the general area of "standard reference materials". This series will present the results of studies and investigations undertaken within the Institute for Materials Research with emphasis on the preparation and characterization of standard reference materials. This subject-oriented series will provide a means for rapid dissemination of this detailed information and we hope will stimulate the use of standard reference materials in science and industry.

W. Wayne Meinke, Chief
Office of Standard Reference Materials

TABLE OF CONTENTS

| | PAGE |
|---|------|
| 1. INTRODUCTION | 1 |
| 2. COPPER IN COPPER-BASE STANDARDS | 5 |
| Cartridge Brass (Electrolytic method) | 6 |
| Residual Copper in Cartridge Brass (Carbamate-Photometric method) | 11 |
| Free-Cutting Brass (Electrolytic method) | 15 |
| Residual Copper in Free-Cutting Brass (Carbamate-photometric method) | 17 |
| Naval Brass (Electrolytic method) | 18 |
| Red Brass, Gilding Metal and Commercial Bronze (Electrolytic method) | 19 |
| Aluminum Brass (Electrolytic method) | 20 |
| 3. LEAD IN COPPER-BASE STANDARDS | 23 |
| Cartridge Brass, Free-Cutting Brass, Naval Brass, Red Brass, Gilding Metal, Commercial Bronze and Aluminum Brass (Molybdate- gravimetric method) | 24 |
| Cartridge Brass, Naval Brass, Red Brass, Gilding Metal, Commercial Bronze and Aluminum Brass (Dithizone-Photometric method). | 26 |
| 4. IRON IN COPPER-BASE STANDARDS | 35 |
| Cartridge Brass, Free-Cutting Brass, Naval Brass, Red Brass, Gilding Metal, Commercial Bronze and Aluminum Brass (1,10-phenanthroline- photometric method) | 36 |
| 5. NICKEL IN COPPER-BASE STANDARDS | 41 |
| Cartridge Brass, Free-Cutting Brass, Naval Brass, Red Brass, Gilding Metal and Commercial Bronze (Dimethylglyoxime-photometric method) | 41 |
| 6. ZINC IN COPPER-BASE STANDARDS | 46 |

OTHER NBS PUBLICATIONS IN THIS SERIES

NBS Misc. Publ. 260, Standard Reference Materials: Catalog and Price List of Standard Materials Issued by the National Bureau of Standards, January 1965. In press.* (Supersedes NBS Misc. Publ. 241, March 1962.)

NBS Misc. Publ. 260-1, Standard Reference Materials: Preparation of NBS white Cast Iron Spectrochemical Standards, June 1964. 30 cents.*

NBS Misc. Publ. 260-2, Standard Reference Materials: Preparation of NBS Copper-Base Spectrochemical Standards, October 1964. 35 cents.*

NBS Misc. Publ. 260-3, Standard Reference Materials: Metallographic Characterization of an NBS Spectrometric Low-Alloy Steel Standard, October 1964. 20 cents.*

NBS Misc. Publ. 260-4, Standard Reference Materials: Sources of Information on Standard Reference Materials, February 1965. 20 cents.*

NBS Misc. Publ. 260-5, Standard Reference Materials: Accuracy of Solution X-Ray Spectrometric Analysis of Copper-Base Alloys, March 1965. 25 cents.*

NBS Misc. Publ. 260-6, Standard Reference Materials: Methods for the Chemical Analysis of White Cast Iron Standards, July 1965. 45 cents.*

* Send orders with remittance to: Superintendent of Documents, U.S. Government Printing Office, Washington, D.C. 20402. Remittance from foreign countries should include an additional one-fourth of the purchase price for postage.

LIST OF FIGURES

| FIGURE NO. | PAGE |
|---|------|
| 1. All-glass still used for the determination of antimony in standard copper-base materials | 90 |

LIST OF TABLES

| TABLE NO. | |
|--|---|
| 1. Planned compositions of NBS copper-base spectrochemical standards | 2 |
| 2. Results obtained by applying the recommended procedure in analyses of high-purity copper. | 5 |

TABLE OF CONTENTS (Con't)

| | PAGE |
|---|------|
| Cartridge Brass, Free-Cutting Brass, Naval Brass, Red Brass, Gilding Metal, Commercial Bronze and Aluminum Brass (Sulfide-oxide-gravimetric method) | 46 |
| 7. ALUMINUM IN COPPER-BASE STANDARDS | 51 |
| Cartridge Brass and Naval Brass (Aluminum-photometric method) | 51 |
| Aluminum Brass (Cyanide-8-hydroxyquinoline-gravimetric method) | 57 |
| 8. PHOSPHORUS IN COPPER-BASE STANDARDS | 61 |
| Cartridge Brass, Free-Cutting Brass, Naval Brass, Red Brass, Gilding Metal, Commercial Bronze and Aluminum Brass (Molybdenum Blue-photometric method) | 61 |
| 9. TIN IN COPPER-BASE STANDARDS | 66 |
| Cartridge Brass, Free-Cutting Brass, Naval Brass, Red Brass, Gilding Metal and Commercial Bronze (Iodimetric-titration method) | 67 |
| 10. MANGANESE IN COPPER-BASE STANDARDS | 71 |
| Cartridge Brass and Naval Brass (Potassium periodate-photometric method) | 71 |
| 11. ARSENIC IN COPPER-BASE STANDARDS | 76 |
| Cartridge Brass and Aluminum Brass (Molybdenum Blue-photometric method) | 76 |
| 12. SILICON IN COPPER-BASE STANDARDS | 82 |
| Cartridge Brass and Aluminum Brass (Molybdenum Blue-photometric method) | 82 |
| 13. ANTIMONY IN COPPER-BASE STANDARDS | 89 |
| Cartridge Brass and Aluminum Brass (Distillation-bromate method) | 89 |
| 14. REFERENCES | 96 |

STANDARD REFERENCE MATERIALS:
METHODS FOR THE CHEMICAL ANALYSIS OF
NBS COPPER-BASE SPECTROCHEMICAL STANDARDS

Rosemond K. Bell

Institute for Materials Research
National Bureau of Standards

The methods for chemical analysis described in this publication are those used in the laboratories of the National Bureau of Standards for the determination of the various constituents of 21 NBS copper-base spectrochemical standards. The methods cover procedures for the analysis of 7 principal standard alloys known as cartridge brass, free-cutting brass, naval brass, red brass, gilding metal, commercial bronze, and aluminum brass of nominal, high, and low composition. The methods are selected or designed primarily for accuracy rather than for speed. References are listed for additional information on chemical analysis of copper-base alloys.

1. INTRODUCTION

In 1955 the National Bureau of Standards, in cooperation with the copper industry, planned the chemical compositions for three standards for each of seven copper-base alloys. The nominal compositions of the seven principal types of copper-base alloys are: gilding metal, 95 percent copper and 5 percent zinc; commercial bronze, 90 percent copper and 10 percent zinc; red brass, 85 percent copper and 15 percent zinc; cartridge brass, 70 percent copper and 30 percent zinc; free-cutting brass, 61.5 percent copper, 35.5 percent zinc, and 3 percent lead; naval brass, 60 percent copper, 39.25 percent zinc, and 0.75 percent tin; and aluminum brass, 76 percent copper, 22 percent zinc, and 2 percent aluminum. The final compositions adopted by NBS and accepted by industry are shown in table 1

Table 1. Planned Compositions of NBS Copper-Base Spectrochemical Standards.

| Designation | Code | Cu | Pb | Fe | Zn | Other and Remarks | | | |
|---------------------------|-------|------------------------|------------------------|------------------------|-----------|---------------------------|-----------------------|-----------|------|
| Cartridge Brass | Spec. | 68.5-71.5 | 0.07 max. ^a | 0.05 max. ^b | Remainder | Total Others 0.15 max. | | | |
| 1100 | A1 | 67.0 | 0.10 | 0.10 | (22.90) | *(see below) | | | |
| 1101 | A2 | 70.0 | 0.05 | 0.04 | (29.84) | *(see below) | | | |
| 1102 | A3 | 73.0 | 0.02 | 0.01 | (26.94) | *(see below) | | | |
| Free-Cutting Brass | Spec. | 60.0-63.0 | 2.5-3.7 | 0.15 ^c | Remainder | Other 0.50 max. | | | |
| 1103 | B1 | 59.0 | 4.0 | 0.30 | (35.75) | Sn | Ni | | |
| 1104 | B2 | 61.5 | 3.0 | 0.10 | (34.93) | 0.80 | 0.15 | | |
| 1105 | B3 | 64.0 | 2.0 | 0.05 | (33.72) | 0.40 | 0.07 | | |
| | | | | | | 0.2 | 0.03 | | |
| Naval Brass | Spec. | 59.0-62.0 ^d | 0.20 max. | 0.10 max. | Remainder | Sn 0.5-1.0 | Total Other 0.10 max. | | |
| 1106 | C1 | 58.7 | 0.03 | 0.02 | (40.40) | | Ni | Al | Mn |
| 1107 | C2 | 61.0 | 0.15 | 0.07 | (37.40) | 0.75 | 0.06 | 0.02 | 0.02 |
| 1108 | C3 | 65.0 | 0.06 | 0.08 | (34.37) | 1.2 | 0.10 | 0.08 | -- |
| | | | | | | 0.42 | 0.03 | 0.03 | 0.01 |
| Red Brass (05-15) | Spec. | 84.0-86.0 | 0.06 max. | 0.05 max. | Remainder | Total Other 0.15 max. | | | |
| 1109 | D1 | 82.0 | 0.07 | 0.07 | (17.66) | Sn | Ni | | |
| 1110 | D2 | 84.5 | 0.03 | 0.03 | (15.34) | 0.10 | 0.10 | | |
| 1111 | D3 | 87.0 | 0.01 | 0.01 | (12.94) | 0.05 | 0.05 | | |
| | | | | | | 0.02 | 0.02 | | |
| Gilding Metal (95-5) | Spec. | 94.0-96.0 | 0.05 max. | 0.05 max. | Remainder | Total Other 0.15 max. | | | |
| 1112 | E1 | 93.5 | 0.07 | 0.07 | (6.16) | Sn | Ni | | |
| 1113 | E2 | 95.0 | 0.03 | 0.03 | (4.84) | 0.10 | 0.10 | | |
| 1114 | E3 | 96.5 | 0.01 | 0.01 | (3.44) | 0.05 | 0.05 | | |
| | | | | | | 0.02 | 0.02 | | |
| Commercial Bronze (90-10) | Spec. | 89.0-91.0 | 0.05 max. | 0.05 max. | Remainder | Total Other 0.15 max. | | | |
| 1115 | F1 | 88.0 | 0.01 | 0.07 | (11.72) | Sn | Ni | | |
| 1116 | F2 | 90.5 | 0.03 | 0.03 | (9.34) | 0.10 | 0.10 | | |
| 1117 | F3 | 93.0 | 0.07 | 0.01 | (6.88) | 0.05 | 0.05 | | |
| | | | | | | 0.02 | 0.02 | | |
| Aluminum Brass | Spec. | 76.0-79.0 | 0.07 max. | 0.06 max. | Remainder | Al 1.8-2.5 | As, Sb, or P | 0.02-0.10 | |
| 1118 | G1 | 75.0 | 0.02 | 0.07 | (21.97) | Al | As | Sb | P |
| 1119 | G2 | 77.5 | 0.05 | 0.03 | (20.14) | 2.8 | 0.01 | 0.01 | 0.12 |
| 1120 | G3 | 80.0 | 0.10 | 0.10 | (18.14) | 2.1 | 0.06 | 0.06 | 0.06 |
| | | | | | | 1.5 | 0.12 | 0.12 | 0.01 |

*Total Other Impurities 0.15 Max.

| Cartridge Brass (continued) | Spec. | Sn | Ni | Sb | As | Mn | Si | Bi | Te | Al | Be | P | Cd | Ag |
|-----------------------------|-------|-------|-------|-------|-------|--------|-------|--------|-------|--------|---------|-------|-------|-------|
| 1100 | A1 | 0.05 | 0.05 | 0.02 | 0.02 | 0.02 | 0.01 | 0.0008 | 0.005 | 0.008 | 0.002 | 0.008 | 0.015 | 0.020 |
| 1101 | A2 | 0.015 | 0.015 | 0.01 | 0.01 | 0.01 | 0.005 | 0.0001 | 0.002 | 0.003 | 0.001 | 0.003 | 0.003 | 0.009 |
| 1102 | A3 | 0.005 | 0.005 | 0.005 | 0.005 | 0.0035 | 0.002 | 0.0003 | 0.001 | 0.0003 | 0.00015 | 0.001 | 0.005 | 0.004 |

^a Pb may be 0.30 max. for some specifications.
^b Fe may be 0.10 max. for some specifications.
^c Fe allowed to 0.35 max. for one specification.
^d Cu allowed to 65% for some specifications.

for each alloy type. All of the elements required by chemical specifications were included for each type of alloy; also, all of the trace elements of interest were purposely included only in the cartridge brass series. Some typical uses of gilding metal are in coinage, munitions and jewelry. Commercial

bronze is used in architecture, hardware and primer caps. Red brass is used in industry for condenser and heat-exchange tubes, fire extinguishers, badges and tags. Cartridge brass is used in munitions for ammunition components, in the automotive field for radiator cores and tanks and in electrical hardware. Free-cutting brass is used in gears and pinions and in automatic high-speed screw-machine parts. Naval brass is used in condenser-plates, marine hardware and propeller shafts. Aluminum brass is used in condensers, evaporator and heat-exchanger tubes and distiller tubes [1]. These brass standards were made to comply with the requirements that a composition standard must be stable, homogeneous and in a form convenient for use. The preparation of these standards is described in NBS Miscellaneous Publication 260-2, Standard Reference Materials: Preparation of NBS Copper-Base Spectrochemical Standards [2].

One of the important requirements in the development of a composition brass standard is the method of analysis. These methods are a collection of procedures used over a period of several years.

The electrolytic method is used for the determination of copper for it is the most accurate procedure. Lead is stripped off the anode and is determined gravimetrically with ammonium molybdate or photometrically with dithizone.

Iron and nickel in the electrolyte from the electro-deposition of copper are determined photometrically on aliquot portions of the solution with 1, 10-phenanthroline and dimethyl-

glyoxime, respectively.

Zinc in the electrolyte is determined gravimetrically in an aliquot portion of the solution, after adjustment to pH 2, by precipitation with hydrogen sulfide and ignition to the oxide.

Aluminum less than 0.1 percent is determined photometrically with aluminon after separation of the other constituents by electrolysis in a mercury cathode cell. Aluminum of higher content is determined gravimetrically with 8-hydroxyquinoline after treating an aliquot portion of the electrolyte with citric acid, hydrogen peroxide, ammonium hydroxide and sodium cyanide.

Phosphorus in the electrolyte is determined photometrically in an aliquot portion by the molybdenum blue method, or photometrically after precipitation of phosphorus as ammonium phosphomolybdate in a separate sample.

Tin is determined in a separate sample by the iodimetric-titration method.

Silicon is determined in a separate sample by the butyl alcohol extraction-molybdenum blue-photometric method.

Manganese is determined in a separate sample photometrically by the periodate method.

Arsenic in a separate sample is precipitated with sodium hypophosphite, dissolved in an iodine solution, and determined photometrically by the molybdenum blue method.

Antimony in a separate sample is removed by distillation with hydrochloric acid and titrated with standard potassium bromate solution.

2. COPPER IN COPPER-BASE STANDARDS

The electrolytic method is the most accurate procedure for the determination of copper if interfering metals, such as antimony, arsenic, and tin, are removed and complete recovery of copper in the electrolyte is made [3]. Silver is completely deposited on the cathode and a correction for it must be made. As much as 5 g of copper can be handled by this method as against 0.2 g or less in other methods. Table 2 indicates the accuracy that can be obtained by electrolysis. The procedure is useful, in cases where sulfates are objectionable, for separating copper in large samples.

Table 2. Results obtained by applying the recommended procedure in analyses of high-purity copper.

| Copper | | |
|-----------------------|---------------------------------------|----------------------------|
| <u>Added</u> grams | <u>Recovered^a</u> grams | <u>Difference</u> grams |
| 0.0580 | 0.0580 | 0 |
| .0570 | .0571 | +0.0001 |
| .1568 | .1568 | 0 |
| .1505 | .1506 | + .0001 |
| 1.0056 | 1.0055 | - .0001 |
| 1.0056 | 1.0054 | - .0002 |
| 1.0075 | 1.0073 | - .0002 |
| 1.0052 | 1.0051 | - .0001 |
| 1.0006 | 1.0007 | + .0001 |
| 1.0005 | 1.0006 | + .0001 |
| 2.0007 | 2.0008 | + .0001 |
| 2.0001 | 2.0001 | 0 |

^a A little copper was usually left in the electrolyte, less than 0.1 mg in electrolyses of 50 to 150 mg of copper, from 0.05 to 0.2 mg in those involving 1 to 2 g of copper, and from 0.1 to 0.3 mg in those where 5 g of copper was used.

The iodimetric method is next in use and in accuracy and has the advantage of being less susceptible to interfering elements. The thiocyanate method with its gravimetric and volumetric variations is about equal to the iodimetric method [3].

The procedure for the electrolytic determination of copper was checked for its reliability by the repetitive analysis of synthetic samples approximating the composition of cartridge brass prepared with metals of high-purity.

The danger of retarded or incomplete deposition of copper in nitric acid solution alone is avoided by the addition of one or two drops of 0.1 N hydrochloric acid before electrolysis is started [4].

Cartridge Brass

Method: Electrolytic

This electrolytic method covers the procedure for the chemical analysis of cartridge brass having compositions within the limits specified: copper, 68.5 - 71.5; lead, 0.07 maximum; iron, 0.05 maximum; and zinc, the remainder. The total of all the other impurities is 0.15 maximum and includes tin, nickel, antimony, arsenic, manganese, silicon, bismuth, tellurium, aluminum, beryllium, phosphorus, cadmium and silver.

Scope

This method is recommended for the determination of copper in the range of 67 to 73 percent. The standard deviation at this range is 0.02 percent.

Principle of Method

The electrolysis is performed at constant current in a cool, clear nitric acid solution free of antimony, arsenic, and tin by slow deposition on sand-blasted platinum gauze cylinders without stirring. The cathode deposit is contaminated with silver and correction for it is made.

Interferences

Antimony, arsenic, tin, silver, bismuth, and quadrivalent tellurium contaminate the copper deposit. Antimony, arsenic, and tin are separated in a nitric acid solution; the concentration of bismuth is so low in the cartridge brass samples that it is practically negligible, and correction is made for silver in the cathode deposit. Tellurium, if present in the deposit, may be determined by nitric acid solution of the deposit, addition of ferric nitrate and precipitation with ammonium hydroxide to remove copper and nitric acid. The precipitate is dissolved in 3 N hydrochloric acid; then sulfurous acid and hydrazine hydrochloride are added to precipitate tellurium.

For the complete separation of antimony and arsenic along with tin by nitric acid digestion, there must be 10 times as much tin as the total amount of antimony and arsenic. If the proportion is less than this, high-purity tin may be added [5].

Apparatus

(a) Current. A source of direct current, conveniently a 110-volt line, or the use of rectifiers to convert 110-volt alternating current, or a commercial electrolysis apparatus.

(b) Suitable resistances to permit regulation of the amperage and voltage.

(c) Electrodes. Platinum electrodes may be made of wire gauze, 400 meshes per cm^2 (50 meshes per linear-inch) and cylindrical in shape. The gauze should be woven with wire about 0.0085 in. (0.21 mm) in diameter. The cathode cylinder should be 1.5 in. (38 mm) in diameter and 2 in. (50 mm) in height. The anode cylinder should be 2 in. in diameter and 2 in. in height. The stem should be made of a platinum alloy with a diameter of about 0.051 in. (1.3 mm) and the overall height of the stem and gauze should be about 5.5 in. (140 mm).

(d) Spectrophotometer with matched cells.

Reagents

(a) High-purity tin.

(b) Nitric acid (sp gr 1.42).

- (c) Perchloric acid (70%).
- (d) Hydrobromic acid (48%).
- (e) Hydrochloric acid (0.1 N).

Procedure

(a) Transfer 5 g (accurately weighed) of the sample and 20 mg of high-purity tin (NBS SS 42 F) to a 400-ml beaker and cover. Add 25 ml of water and cool in ice water in a hood. Add HNO_3 (sp gr 1.42) in small portions (2 or 3 ml) until a total of 20 ml has been added.

(b) After action ceases, heat on a steam bath and then boil gently until brown fumes have been expelled. Dilute to about 200 ml volume with hot water and add a small amount of paper pulp. Stir, digest on a steam bath several hours or preferably overnight. Filter the hot solution through a retentive filter paper containing paper pulp and wash several times with hot HNO_3 (1:99)*. Reserve the filtrate and washings (A).

(c) Transfer the paper and contents to the original beaker, add 20 ml of HNO_3 (sp gr 1.42) and 10 ml of HClO_4 (70%)**. Heat to copious white fumes to destroy organic matter and expel HNO_3 . Cool somewhat and wash

* This symbol denotes 1 volume of concentrated nitric acid (sp gr 1.42) diluted with 99 volumes of water. This system of specifying diluted acids is used throughout this paper.

** Hot concentrated HClO_4 in contact with reducing matter may produce violent explosions. Nitric acid should always be used with HClO_4 .

the wall of the beaker with a few ml of water. Add 20 ml of HBr (48%) and digest on a steam bath a few minutes. Heat just to white fumes to volatilize tin. Cool, add 15 ml of HBr (48%) and repeat the heating to fumes. If the solution is turbid repeat the addition of HBr and the heating until a clear solution is obtained. Evaporate the HClO_4 solution practically to dryness and cool. Add 3 ml of HNO_3 (1:1) and 5 ml of water and heat to dissolve the residue. Combine the solution with the reserved filtrate (A).

(d) Dilute the combined solutions to about 300 ml and electrolyze for 30 to 60 minutes with platinum gauze electrodes, by setting the current range with resistances at approximately 0.5 ampere. Add 2 drops of HCl (0.1 N), and electrolyze overnight. When the deposition of copper is complete wash the cathode quickly and thoroughly with a jet of water from a wash bottle. Wash the anode carefully and then immerse both electrodes in a 400-ml beaker of water. Reserve the electrolyte and washings (B). Rinse the cathode in alcohol and dry it for 3 to 5 min. at 100°C . Cool and weigh the cathode deposit as copper and silver. Transfer the anode (c) to a 250-ml beaker and reserve for the determination of lead. Dissolve the cathode deposit in HNO_3 and determine silver in the solution as AgCl [3].

Calculation

Calculate the percentage of copper as follows:

$$\text{Copper, percent} = \frac{A - B}{C} \times 100$$

where:

A = grams of cathode deposit

B = grams of silver in the cathode deposit, and

C = grams of sample used.

Note. The electrolyte and washings (solution B) are checked for residual copper by the diethyl-dithiocarbamate-photometric method.

Residual Copper in Cartridge Brass

Method: Photometric

The diethyldithiocarbamate-photometric method is recommended for the determination of the residual copper in the electrolyte and washings (solution B).

Scope

This method is recommended for the determination of the copper remaining in the electrolyte ranging from 0.001 to 0.05 percent (0.05 to 2.5 mg of copper). The standard deviation for copper in the range of 0.05 percent is 0.001 percent.

Principle of Method

Sodium diethyldithiocarbamate forms a copper complex in an ammoniacal solution that is extracted with butyl acetate. Photometric measurement is made at 440 mμ.

Concentration Range

The recommended concentration range is 0.01 to 0.05 mg of copper in 20 ml of butyl acetate, using a cell depth of 2 cm.

Stability of Color

The color is stable for at least 1 hour but readings are usually made within 15 minutes after extraction.

Interfering Elements

Nickel interferes but provision in the method has been made for alloys containing up to 80 mg of nickel.

Reagents

(a) Citric acid solution (250 g/liter). Dissolve 125 g of citric acid in about 250 ml of water, add 10 ml of H_2SO_4 (1:1), and dilute to 500 ml.

(b) Disodium ethylenediaminetetraacetate solution (40 g/liter). Dissolve 20 g of disodium ethylenediaminetetraacetate dihydrate $[(NaOOCCH_2)_2 NCH_2CH_2N (CH_2COOH)_2 \cdot 2H_2O]$ in 400 ml of water and dilute to 500 ml.

(c) Sodium diethyldithiocarbamate solution (1.0 g/liter). Dissolve 0.5 g of the carbamate trihydrate $[(C_2H_5)_2 NCS_2Na \cdot 3H_2O]$ in 500 ml of water.

(d) Butyl acetate.

(e) Standard copper solution (A) (1 ml = 0.10 mg of Cu). Dissolve 0.100 g of high-purity copper (NBS SS 45c) in 20 ml of HNO_3 (1:1) in a 400-ml beaker.

Boil gently until brown fumes have been expelled, cool, and transfer to a liter volumetric flask. Dilute to the mark with water and mix.

(f) Standard copper solution (B) (1 ml = 0.01 mg of Cu). Transfer 50 ml of standard copper solution (A) with a pipet to a 500-ml volumetric flask containing 10 ml of HNO_3 (1:1), dilute to the mark with water and mix. Prepare this solution freshly as needed.

Preparation of Calibration Curve

(a) Transfer 0.0, 1.0, 2.0, 3.0, 4.0, and 5.0 ml of standard copper solution (B) to six 125-ml separatory funnels. Dilute to 25 ml with water.

(b) Add 10 ml of citric acid solution. Neutralize to litmus with NH_4OH , cooling if necessary, and add 5 ml in excess.

(c) Add 15 ml of the ethylenediaminetetraacetate solution, mix, and cool to room temperature. Add 10 ml of the carbamate solution and shake 30 to 60 seconds. Add 20 ml of the butyl acetate with a pipet and shake for 60 seconds. Cool in running water for 2 to 3 minutes and repeat the shaking for 60 seconds. Cool and allow the layers to separate.

(d) Drain off completely the lower aqueous layer and discard it. Add 25 ml of H_2SO_4 (5:95) to the funnel, shake for 15 seconds, and cool in running water. Repeat the shaking, allow the layers to separate, then

drain off the aqueous layer and discard it. Transfer the butyl acetate extract to a test tube and stopper the tube.

(e) Transfer the butyl acetate extract to a 2-cm absorption cell and measure the absorbance on a spectrophotometer at approximately 440 m μ . Use butyl acetate to set the zero absorbance.

Plot the values obtained against milligrams of copper per 20 ml of solution.*

Procedure

(a) Dilute the reserved electrolyte (B) to 500 ml with water in a volumetric flask and mix. Transfer 25 ml of the solution with a pipet to a 125-ml separatory funnel and proceed as directed in sections (b) through (e) in preparation of the calibration curve.

(b) Using the value obtained, read from the calibration curve the number of milligrams of copper present in the aliquot portion.

(c) Carry a blank through all of the operations used for the analysis sample.

Calculation

Calculate the percentage of copper as follows:

$$\text{Copper, percent} = \frac{A - B}{C \times 10}$$

* Plot absorbance A, against the respective concentrations on ordinary graph paper; or concentration C, against percentage transmission on semi-logarithmic paper using the semi-log scale for the percentage T values.

where:

A = mg of copper in the final solution

B = mg of copper in the blank, and

C = g of sample in the final solution.

Add the percentage of copper to that obtained by electrolysis.

Free-Cutting Brass

Method: Electrolytic

This electrolytic method covers the procedure for the chemical analysis of free-cutting brass having compositions within the limits specified: copper, 60.0 - 63.0; lead, 2.5 - 3.7; iron, 0.15 maximum and zinc, the remainder. The maximum tin and nickel content is 0.50.

Scope

This method is recommended for the determination of copper in the range of 59 to 64 percent. The standard deviation at this range is 0.02 percent.

Principle of Method

The electrolysis is performed at constant current in a clear, cool nitric acid solution free of tin by slow deposition on platinum gauze cylinders without stirring.

Interferences

Tin contaminates the copper deposit and is separated in a nitric acid solution before electrolysis.

Apparatus

See method for cartridge brass.

Reagents

Use the same reagents described for cartridge brass with the exception of high-purity tin. The absence of antimony and arsenic obviates the necessity of adding tin.

Lead in the free-cutting brass is the highest of the seven spectrochemical standard samples and this makes it necessary to reduce the size of the sample for electrolysis.

Procedure

Transfer 2 g* (accurately weighed) of the sample to a 400-ml beaker and cover. Add 10 ml of water and cool in ice water in a hood. Add HNO_3 (sp gr 1.42) in 2-ml portions until a total of 10 ml has been added. Proceed as directed in sections (b), (c), and (d) in the procedure for cartridge brass with the exception to set the current range with resistances at approximately 0.3 ampere. Make no correction for silver in the cathode deposit and add the HCl before starting the electrolysis, as silver is not present in the alloy.

*The size of the sample used for the determination of copper in free-cutting brass by electrolysis is reduced because of the high percentage of lead in this brass.

Calculation

Calculate the percentage of copper as follows:

$$\text{Copper, percent} = \frac{A}{B} \times 100$$

where:

A = grams of cathode deposit, and

B = grams of sample used.

The electrolyte and washings (solution B) are checked for residual copper by the diethyldithiocarbamate-photometric method.

Residual Copper in Free-Cutting Brass

Evaporate the electrolyte and washings (B) to about 150 ml volume. Cool, dilute to 200 ml in a volumetric flask with water, and mix. Transfer a 10-ml aliquot portion of the solution to a 125-ml separatory funnel, dilute to 25 ml, and proceed as directed in sections (b) through (e) in preparation of calibration curve for the determination of residual copper by the diethyldithiocarbamate-photometric method in the cartridge brass electrolyte. Add the percentage of copper to that obtained by electrolysis.

Transfer the anode (C) to a 250-ml beaker and reserve for the determination of lead. If some of the lead dioxide deposit on the anode is not adherent, recover it at once by filtering the electrolyte through a rapid paper and adding the lead dioxide to the 250-ml beaker containing the anode.

Naval Brass

Method: Electrolytic

This electrolytic method covers the procedure for the chemical analysis of naval brass having compositions within the limits specified: copper, 59.0 - 62.0; lead, 0.20 maximum; iron 0.10 maximum and zinc, the remainder. The limits for tin is 0.5 - 1.0 while the total due to nickel, aluminum and manganese is 0.10 maximum.

Scope

This method is recommended for the determination of copper in the range of 58 to 65 percent. The standard deviation at this range is 0.02 percent.

Principle of Method

See free-cutting brass method.

Interferences

See free-cutting brass method.

Apparatus

See free-cutting brass method.

Reagents

See free-cutting brass method.

Procedure

Proceed as directed in the procedure for cartridge brass except omit the addition of tin and add the HCl before starting the electrolysis, as silver is not present.

Calculation

See free-cutting brass method.

Determine the residual copper in the electrolyte as directed in the cartridge brass method, using the diethyl-dithiocarbamate-photometric method.

Red Brass, Gilding Metal, and Commercial Bronze

Method: Electrolytic

This electrolytic method covers the procedure for the chemical analysis of red brass, gilding metal, and commercial bronze having compositions within the limits specified.

| | Red Brass | Gilding Metal | Commercial Bronze |
|----------------------------------|-----------|---------------|-------------------|
| Copper | 84.0-86.0 | 94.0-96.0 | 89.0-91.0 |
| Lead | 0.06 max. | 0.05 max. | 0.05 max. |
| Iron | 0.05 max. | 0.05 max. | 0.05 max. |
| Zinc | remainder | remainder | remainder |
| Total others (tin and nickel) | 0.15 max. | 0.15 max. | 0.13 max. |

Scope

This method is recommended for the determination of copper in the range of 82 to 96.5 percent. The standard deviation at this range is 0.02 percent.

Principle of Method

See free-cutting brass methods.

Interferences

See free-cutting brass methods.

Apparatus

See cartridge brass method.

Reagents

See free-cutting brass method.

Procedure

See naval brass method.

Calculation

See free-cutting brass method.

Determine the residual copper in the electrolyte as directed in the cartridge brass method, using the diethyl-dithiocarbamate-photometric method.

Aluminum Brass

Method: Electrolytic

This electrolytic method covers the procedures for the chemical analysis of aluminum brass having compositions within the limits specified: copper,

76.0 - 79.0; lead, 0.07 maximum; iron, 0.06 maximum; aluminum, 1.8 - 2.5; arsenic, antimony or phosphorus, 0.02 - .10 and zinc the remainder.

Scope

This method is recommended for the determination of copper in the range of 75 to 80 percent. The standard deviation at this range is 0.02 percent.

Principle of Method

The electrolysis is performed at constant current in a clear, cool nitric acid solution free of antimony and arsenic by slow deposition on platinum gauze cylinders without stirring.

Interferences

Antimony and arsenic contaminate the copper deposit and are separated by coprecipitation with tin in a nitric acid solution before electrolysis.

Apparatus

See cartridge brass method.

Reagents

See cartridge brass method.

Procedure

Proceed as directed in the procedure for cartridge brass, adding 10 mg of high-purity tin to 5 grams of sample 1118, or 50 mg of tin to 5 g of sample 1119, or 100 mg of tin to 5 g of sample 1120 to

separate antimony and arsenic by coprecipitation.

Add the HCl before starting the electrolysis.

Calculation

See free-cutting brass method.

Determine the residual copper in the electrolyte as directed in the cartridge brass method, using the diethyl-dithiocarbamate-photometric method.

3. LEAD IN COPPER-BASE STANDARDS

The precipitation of lead as the molybdate, PbMoO_4 , is a preferred procedure for the gravimetric determination of lead because lead molybdate is less soluble than either lead sulfate or lead chromate. The molybdate precipitate also undergoes no change on ignition and has the advantage of a more favorable gravimetric factor [6]. Since lead forms insoluble compounds with arsenate and phosphate, a separation of lead must be made before it is precipitated with molybdate. This may be done conveniently by electrodeposition.

Although the precipitation of lead as sulfate is recommended for the determination of lead, the solubility of lead sulfate is higher than what is desirable for quantitative separation and recoveries involving 1 or 2 mg of lead must be made [7]. Silica is dehydrated and separates with the lead sulfate. Silver and bismuth also contaminate lead sulfate if they are present.

Although lead chromate is more insoluble than lead sulfate and is preferred for precipitation of lead, it is difficult to obtain a precipitate that corresponds exactly with the formula PbCrO_4 . Lead can be determined as the chromate by precipitation from a homogeneous solution [6].

Differences of opinion exist over optimum conditions for electrolytic deposition of lead. The lead dioxide deposited on the anode does not correspond exactly to the

formula PbO_2 and is contaminated with manganese, silver, and bismuth if they are present [6].

Organic precipitants used for the gravimetric determination of lead are salicylaldehyde, thionalide, and mercaptobenzothiazole but they are not selective.

Titrimetric methods for lead are useful as rapid control methods.

The dithizone (diphenylthiocarbazone) method, while not specific, is used for the accurate, photometric determination of lead less than 0.1 percent by controlling the pH and by complexing the interfering ions.

Cartridge Brass, Free-Cutting Brass, Naval Brass,
Red Brass, Gilding Metal, Commercial
Bronze and Aluminum Brass

Method: Molybdate - Gravimetric

Scope

This method is recommended for the determination of lead in the range of 0.02 to 4 percent. The standard deviation at the high range is 0.01 percent and at the low range 0.002 percent.

Principle of Method

The anode deposit of lead and manganese (if present) from the electrodeposition of copper is dissolved in nitric acid and hydrogen peroxide. Citric acid, ammonium hydroxide and ammonium molybdate are added to precipitate lead as $PbMoO_4$. The precipitate is ignited at $625^\circ C$ and weighed.

Interferences

Bismuth, tin, silver, arsenates, and phosphates interfere but bismuth in the cartridge brass is practically negligible, tin and arsenic are separated before electrodeposition, and lead is separated from phosphates as PbO_2 on the anode and from silver, which deposits on the cathode.

Apparatus

Muffle furnace.

Reagents

(a) Ammonium molybdate solution (50 g/liter).

Dissolve 10 g of ammonium molybdate $(\text{NH}_4)_6\text{Mo}_7\text{O}_{24} \cdot 4\text{H}_2\text{O}$ in 200 ml of water by heating gently. If the solution is not clear, filter it. One ml precipitates about 55 mg of lead.

(b) Ammonium nitrate solution (50 g of NH_4NO_3 per liter plus a few drops of NH_4OH).

(c) Citric acid (reagent grade).

Procedure

(a) Add a mixture of 15 ml of HNO_3 (1:1), 10 ml of water, and 1 to 2 ml of H_2O_2 (30%) to the beaker containing the reserved anode (c) after the electrodeposition of copper. Strip the deposit of lead and manganese (if present) by rotating the electrode in the solution. Wash and remove the electrode. Evaporate the solution just to dryness. Add 10 ml of HNO_3 (1:1) and 50 ml of water.

Add 2 g of citric acid and neutralize the solution (litmus) with NH_4OH . Add 5 ml in excess and dilute to 100 ml. Heat to boiling, add 10 ml of ammonium molybdate solution, and boil a few minutes until the lead molybdate has coagulated. Heat on a steam bath for 10 minutes, filter through a retentive filter paper containing paper pulp, and wash thoroughly with the hot ammoniacal NH_4NO_3 solution.

(b) Transfer the paper and precipitate to a weighed porcelain crucible, and ignite to constant weight in a muffle furnace at 600 to 650 °C. Cool in a desiccator, and weigh as PbMoO_4 .

Calculation

Calculate the percentage of lead as follows:

$$\text{Lead, percent} = \frac{\text{g of PbMoO}_4 \times 0.564 \times 100}{\text{g of sample}}$$

Cartridge Brass, Naval Brass, Red Brass, Gilding Metal, Commercial Bronze and Aluminum Brass

The dithizone method is the best procedure for the colorimetric determination of lead because of its great sensitivity. The concentration range recommended for lead is 1 to 20 μg in about 10 to 25 ml. When a solution of dithizone in CHCl_3 or CCl_4 is mixed with an aqueous solution

of lead, a red-colored dithizonate is formed which is soluble in the organic solvent and is used for the photometric determination. The dithizone method may be used for the determination of lead in all the spectrochemical copper-base standards with the exception of free-cutting brass. Other colorimetric methods for lead are: the tetramethyldiaminodiphenylmethane procedure based on the formation of a blue color with lead in glacial acetic acid; the resorcinol procedure in which a water-soluble red complex is formed with lead at pH 10; the diethyldithiocarbamate procedure based on extraction of the lead complex into CCl_4 and formation of a brown solution with copper sulfate; and the lead chloride method, based on absorption in the ultraviolet region [6].

Method: Dithizone - Photometric

Scope

This method covers the determination of lead in the range of 0.01 to 0.1 percent. Higher concentrations are best determined by the electrolytic or molybdate method. The standard deviation at this range is 0.0002 percent.

Principle of Method

Lead dithizonate is extracted from a buffered cyanide solution at pH 8.5 to 9.0 with a CCl_4 solution of dithizone. The lead dithizonate is transferred to

a buffered solution of pH 3.4, extracted again at a higher pH with dithizone and excess dithizone in the CCl_4 is removed by extraction with an ammoniacal cyanide buffer solution. Photometric measurement of the lead dithizonate is made at approximately 510 m μ .

Interferences

Copper tends to oxidize dithizone but is separated by electrodeposition. In a basic solution containing cyanide, only stannous tin, thallium, bismuth, and lead are extracted with a dithizone solution. In the procedure, tin is removed with HBr and bismuth with the acid wash of a CCl_4 solution containing lead and bismuth dithizonates. Thallium, if present, will accompany the lead and thus interferes. Sulfide will cause low lead results. Phosphates may interfere and oxidizing agents should be absent.

Concentration Range

The recommended concentration range is 0.005 to 0.020 mg of lead in 25 ml of CCl_4 , using a cell depth of 2 cm.

Stability of Color

The color is quite stable, but due to the volatile nature of the solvent it is advisable to make the reading promptly.

Apparatus

- (a) pH meter.
- (b) Spectrophotometer with matched cells.
- (c) Glass distillation apparatus and condenser.
- (d) Electrolysis apparatus, electrodes.

Reagents

- (a) Carbon tetrachloride. Add 1400 ml of CCl_4 (c.p.), about 4 g of Ca(OH)_2 and several glass beads to an all-glass still. Collect 1 liter of CCl_4 , rejecting the first and last 200-ml portions.
- (b) Dithizone stock solution. Dissolve 0.025 g of diphenylthiocarbazonone in 250 ml of the distilled CCl_4 . Store in a cool place.
- (c) Dithizone solution (A). Dilute 25 ml of the stock dithizone solution to 250 ml with the distilled CCl_4 . Prepare this solution freshly as needed.
- (d) Dithizone solution (B). Dilute 25 ml of the stock dithizone solution to 125 ml with the distilled CCl_4 . Prepare this solution freshly as needed.
- (e) Citrate-acetate buffer solution (A). Dissolve 100 g of sodium citrate and 100 g of ammonium acetate in water and dilute to 500 ml.
- (f) pH 3.4 buffer solution (B). Dissolve 4.084 g of potassium hydrogen phthalate (SS 84f) in about 200 ml of water. Add 16 ml of H_2SO_4 (1:1) to about

1 liter of water in a 2-liter beaker. Using a pH meter, neutralize the dilute H_2SO_4 with purified NH_4OH (see (g)). Add the potassium hydrogen phthalate solution and dilute to 2 liters with water. Adjust the solution to pH 3.4 with HCl (1:1).

(g) Ammonium hydroxide solution. Bubble ammonia gas, using plastic tubing, into chilled distilled water in a polyethylene bottle until the solution is saturated.

(h) Potassium cyanide solution* (200 g per liter). Dissolve 200 g of KCN (low in lead and sulfide) in water and dilute to 1 liter. Allow to stand overnight, filter, and store the filtrate in a polyethylene bottle.

(i) Ammonium hydroxide-potassium cyanide solution. Dissolve 10 g of KCN in 100 ml of water, add 75 ml of purified NH_4OH , and dilute to 500 ml. Store in a glass-stoppered bottle in a cool place.

(j) Standard lead solution (A) (1 ml = 0.1 mg of Pb). Dissolve 0.100 g of lead (M.P. Pb 49 b) in 20 ml of HNO_3 (1:1) and boil gently to expel brown fumes. Cool, dilute to 1 liter in a volumetric flask, and mix.

(k) Standard lead solution (B) (1 ml = 0.005 mg of Pb). Transfer 10.0 ml of standard lead solution (A) with a pipet to a 200-ml volumetric flask containing

* Caution: Cyanide is extremely poisonous and care should be taken in its use and in its disposal.

5 ml of HNO_3 (1:1). Dilute to the mark and mix.
Prepare this solution immediately before using.

(l) Hydroxylamine hydrochloride.

(m) Dilute nitric acid (15:85). Dilute 75 ml of HNO_3 (sp. gr. 1.42) to 500 ml and cool.

(n) Dilute acetic acid (1:4). Dilute 100 ml of glacial acetic acid to 500 ml with water.

(o) Hydrobromic acid-bromine mixture. Pour 20 ml of bromine into 180 ml of HBr (48%).

Preparation of Calibration Curve

(a) Transfer 0, 1.0, 2.0, 3.0, and 4.0 ml of standard lead solution (B) to five 150-ml beakers. Add 20 ml of HNO_3 (15:85) to each beaker, heat to boiling, and cool.

(b) Add 5 ml of citrate-acetate buffer solution (A) and 10-15 mg of hydroxylamine hydrochloride. In a well-ventilated hood, neutralize the solution with purified NH_4OH until a pH meter reading of about 8 is obtained, stirring while cooling in water. Add 10 ml of the dilute acetic acid (1:4) and cool. Add 20 ml of KCN solution (200 g/l) and cool while stirring. Transfer the solution to a 250-ml separatory funnel, washing the beaker twice with a minimum amount of water.

(c) Add 25 ml of dilute dithizone solution (A), stopper, and shake vigorously for 1 minute. Release the stopper and allow the layers to separate. Transfer

the CCl_4 layer to a clean 125-ml separatory funnel and reserve. Extract the aqueous layer with 5 ml portions of the dilute dithizone solution until the green color of dithizone remains unchanged. Combine the CCl_4 layers in the reserved funnel. Discard the aqueous layer.*

(d) Add 50 ml of pH 3.4 buffer solution (B) and shake vigorously for 2.5 minutes. Allow the layers to separate and discard the CCl_4 layer. Add 7 ml of $\text{NH}_4\text{OH-KCN}$ solution to the aqueous layer and mix. Add 25.0 ml (pipet) of dithizone solution (B) and shake for 5 minutes. Allow the layers to separate completely and transfer the CCl_4 layer to a clean separatory funnel. Discard the aqueous layer.* Add 25 ml of a mixture (made by mixing 100 ml of pH 3.4 buffer solution (B) and 15 ml of $\text{NH}_4\text{OH-KCN}$ solution) and shake gently for 1 minute. Allow the layers to separate and transfer the CCl_4 layer to a dry test tube, stopper, and allow to stand a few minutes. Transfer a suitable portion to a dry 2-cm cell and take the photometric readings at 510 $\text{m}\mu$, using distilled CCl_4 for the initial setting of 100% transmission.

* Use care in the disposal of cyanide solution.

(e) Calibration curve. Plot the photometric readings of the calibration solutions against milligrams of lead per 25 ml of solution.*

Procedure

(a) Transfer 0.250 g of sample to a 150-ml beaker and add 10 ml of HBr-Br₂ mixture. Cover and warm to dissolution. Evaporate to dryness and cool. Add 5 ml of water, 5 ml of HBr (48%), 5 ml of HClO₄ (70%), and heat to copious white fumes. If the solution is cloudy, cool, add 10 ml of water, heat for a few minutes, add more HBr and heat to fumes again. Evaporate the solution just to dryness to expel HClO₄. Cool, add 10 ml of HNO₃ (1:1) to the residue, cover, and heat on a steam bath for 10 minutes. Cool, dilute to 125 ml, add 1 drop of 0.1 N HCl, and electrolyze to remove copper, using platinum gauze electrodes.

(b) Wash the electrodes and separate them from the electrolyte. Discard the cathode deposit of copper. Add 2 ml of HNO₃ (sp gr 1.42) and a few drops of H₂O₂ (30%) to the electrolyte. Immerse the anode in the solution to dissolve any PbO₂ deposit. Wash and remove the anode.

(c) Dilute the electrolyte and washings to 250 ml in a volumetric flask with water and mix. Transfer

* Plot absorbance A, against the respective concentrations on ordinary graph paper; or concentration C, against percentage transmission on semi-logarithmic paper using the semi-log scale for the percentage T values.

an aliquot portion containing 0.005 to 0.02 mg of lead with a pipet to a 150-ml beaker. Evaporate the solution to dryness. Add 20 ml of HNO₃ (15:85) to the residue, heat to boiling, and cool. Proceed as directed in Sections (b), (c) and (d) in preparation of the calibration curve. Carry through the entire procedure a reagent blank, using the same amount of all reagents.

Calculation

Convert the photometric readings of the sample solutions to milligrams of lead by means of the calibration curve. Calculate the percentage of lead as follows:

$$\text{Lead, percent} = \frac{A - B}{C \times 10}$$

where:

A = milligrams of lead found in the sample,

B = milligrams of lead found in the blank, and

C = grams of sample used.

4. IRON IN COPPER-BASE STANDARDS

The 1, 10-phenanthroline method is one of the best procedures for the colorimetric determination of bivalent iron because the soluble red-orange complex formed is stable and conforms to Beer's law. The permissible amount of iron in a volume of 100 ml ranges from 10 to 150 μg , high enough to cover the iron present in cartridge brass, free-cutting brass, and the other five spectrochemical copper-base standard alloys. Other colorimetric methods for iron include the widely used thiocyanate procedure which is simple, rapid, and applicable in strong acid solution but the red color fades on exposure to light; the mercaptoacetic acid procedure based on the formation of a reddish-purple color with bivalent iron in an alkaline solution; the 2, 2-bipyridyl procedure which produces a reddish-purple color with ferrous iron; the salicylic acid procedure based on the formation of an amethyst-colored complex with ferric ions; and disodium-1, 2-dihydroxybenzene-3,5-disulfonate reacts with ferric ion to form a blue complex over a pH range 3.5 to 4.5 and to form a red complex over a pH range 9 to 10.

The amount of iron in the seven spectrochemical standards is below the quantity desirable for determination by gravimetric or titrimetric methods.

Cartridge Brass, Free-Cutting Brass, Naval Brass,
Red Brass, Gilding Metal, Commercial
Bronze and Aluminum Brass

Method: 1,10-phenanthroline-photometric

Scope

This method is recommended for the determination of iron in the range of 0.01 to 0.3 percent. The standard deviation at the high range is 0.005 percent and at the low range 0.002 percent.

Principle of Method

Ferrous iron forms an orange-red soluble complex with 1,10-phenanthroline in slightly acid solution. Photometric measurement is made at approximately 515 m μ .

Interferences

Tin interferes in amounts greater than 5 mg. Zinc reduces the intensity of the iron color. Iron is separated from zinc by precipitation with NH₄OH, using aluminum as a gathering agent.

Concentration Range

The recommended concentration range is 0.01 to 0.15 mg of iron in 100 ml of solution, using a cell depth of about 2 cm.

Stability of Color

The color is stable for several hours.

Apparatus

pH meter, spectrophotometer and matched absorption cells.

Reagents

(a) Hydroxylamine hydrochloride solution (100 g of $\text{NH}_2\text{OH} \cdot \text{HCl}$ per liter). Dissolve 10 g of $\text{NH}_2\text{OH} \cdot \text{HCl}$ in 90 ml of water and filter without washing. Dilute the filtrate to 100 ml and mix.

(b) Sodium acetate solution (40%). Dissolve 400 g of $\text{NaC}_2\text{H}_3\text{O}_2 \cdot 3\text{H}_2\text{O}$ in 600 ml of water and filter without washing. Dilute the filtrate to 1 liter and mix.

(c) 1,10-phenanthroline solution. Add 0.5 g of the monohydrate to 100 ml of water and warm at 80°C to dissolution.

(d) Standard iron solution (A) (1 ml = 0.10 mg of iron). Dissolve 0.100 g of iron (NBS Standard 55d) in 20 ml of HCl (1:1). Cool, transfer the solution to a liter volumetric flask, dilute to the mark, and mix.

(e) Standard iron solution (B) (1 ml = 0.01 mg of Fe). Transfer 50 ml of standard iron solution (A) with a pipet to a 500-ml volumetric flask containing 10 ml of HCl (1:1), dilute to the mark with water, and mix.

(f) Aluminum chloride solution (1 ml = 1.0 mg of Al). Transfer 0.500 g of high-purity aluminum (SS44c) to a 500-ml volumetric flask and add 25 ml of HCl (1:1). Warm to dissolve the metal, cool to room temperature, dilute to the mark with water, and mix.

(g) Ammonium chloride solution (10 g of NH_4Cl per liter). Dissolve 10 g of NH_4Cl in a liter of water and add several drops of NH_4OH .

(h) Citric acid solution (25%). Dissolve 250 g of citric acid in water containing 20 ml of H_2SO_4 (1:1) and dilute to one liter.

Preparation of Calibration Curve

(a) Transfer 0, 1.0, 2.5, 5.0, 10.0, and 15.0-ml aliquot portions of standard iron solution (B) (1 ml = 0.01 mg of Fe) to six 150-ml beakers. Add 5 ml of the AlCl_3 solution and 5 ml of the citric acid solution.

(b) Dilute to about 50 ml. Add 2.0 ml of the 1,10-phenanthroline solution, 2 ml of the hydroxylamine solution, and 10 ml of the sodium acetate solution, mixing after each addition.

(c) Add NH_4OH dropwise and stir the solution until a pH meter indicates a reading between 5.9 and 6.1. Heat on a steam bath for 15 minutes and cool to room temperature. Transfer the solution to a 100-ml volumetric flask and wash the beaker with water. Dilute to the mark with water and mix.

(d) Transfer a suitable portion of the solution to a 2-cm absorption cell and measure the transmittance or absorbance at about 515 μ , using water as a reference solution for 100 percent transmittance or zero absorbance.

(e) Plot the values obtained against milligrams of iron per 100 ml of solution.*

Procedure

(a) Transfer an aliquot portion of the solution of the electrolyte (B) containing 0.01 to 0.15 mg of iron with a calibrated pipet to a 250-ml beaker. Transfer the same volume of aliquot portion of the blank as the volume of the aliquot of the electrolyte used for the determination of iron in the sample. Dilute to 125 ml with water. Add 10 ml of HCl and 5 ml of the AlCl_3 solution. Neutralize with NH_4OH and add 2 ml in excess. Heat to boiling and allow the precipitate to settle. Filter through a medium 9-cm paper and wash with the hot NH_4Cl wash solution and once with water.

(b) Place the paper and contents in the 250-ml beaker and add 15 ml of HNO_3 (sp gr 1.42). Macerate the paper with a stirring rod and add 5 ml of HClO_4 .** Heat to copious white fumes to destroy organic matter. Cool, wash the cover glass and side of the beaker, and evaporate to dryness or until white fumes disappear. Cool and add 2 ml of HCl. Cover, heat on a steam bath for a few

* Plot absorbance A, against the respective concentrations on ordinary graph paper; or concentration C, against percentage transmission on semi-logarithmic paper using the semi-log scale for the percentage T values.

** Hot, concentrated HClO_4 in contact with reducing matter may produce violent explosions. Nitric acid should always be used with HClO_4 .

minutes, and add 5 ml of water. Add 5 ml of the citric acid solution and 15 ml of water. Heat to boiling and digest on a steam bath for 10 minutes. If the iron content of the solution is 0.15 mg or less, filter into a 150-ml beaker and wash with HCl (1:99). Proceed as directed in Sections (b) through (d) in preparation of calibration curve. If the iron exceeds 0.15 mg, filter into a 100-ml volumetric flask and wash with HCl (1:99). Dilute to the mark with water, and mix. Take an aliquot that contains between 0.01 and 0.15 mg of iron and transfer to a 150-ml beaker. Proceed as directed in Sections (b) through (d) in preparation of the calibration curve.

(c) Using the value obtained, read from the calibration curve the number of milligrams of iron present in 100 ml of the solution.

(d) Carry a blank through all of the operations used for the analysis sample.

Calculations

Calculate the percentage of iron as follows:

$$\text{Iron, percent} = \frac{A - B}{C \times 10}$$

where:

A = mg of iron in 100 ml of the final solution,

B = mg of iron in 100 ml of the blank, and

C = g of sample in 100 ml of the final solution.

5. NICKEL IN COPPER-BASE STANDARDS

Small amounts of nickel are conveniently determined by colorimetric methods based on the soluble red complex formed by treating nickelic ion in ammoniacal solution with dimethylglyoxime. Dimethylglyoxime is the preferred reagent for the colorimetric determination of nickel because of its selective reaction. The nickel is oxidized with bromine before the addition of the oxime. The extraction of nickel oximate with an immiscible organic solvent like chloroform may be preferable to the dimethylglyoxime-oxidizing agent method in trace analysis.

Other methods, in order of the accuracy of determination of nickel, are (a) dimethylglyoxime-gravimetric for amounts ranging from 20 to 100 milligrams of nickel, (b) the electrolytic, with constant current, in ammoniacal solutions free of cobalt, silver, copper, arsenic, and zinc, and (c) cyanide titration in ammoniacal solutions free of copper, cobalt, and zinc.

Cartridge Brass, Free-Cutting Brass, Naval Brass,
Red Brass, Gilding Metal, and
Commercial Bronze

Method: Dimethylglyoxime-photometric

Scope

This method is recommended for the determination of nickel in the range of 0.005 to 0.2 percent. The standard deviation at the high range is 0.004 percent and the low range 0.001 percent.

Principle of Method

Nickel forms a red-colored soluble nickelic salt with dimethylglyoxime. Photometric measurement is made at approximately 540 m μ .

Interferences

Copper, lead, tin, and most of the manganese are removed and citric acid is added to prevent the precipitation of iron and aluminum which form insoluble hydroxides in an ammoniacal solution.

Concentration Range

The recommended concentration range is from 0.015 to 0.30 mg of nickel in 100 ml of solution, using a cell path of 2 cm.

Stability of Color

The intensity of color increases gradually for about 30 minutes and is stable for at least 1.5 hours.

Apparatus

pH meter, spectrophotometer and matched absorption cells.

Reagents

(a) Standard nickel solution (A) (1 ml = 0.50 mg of Ni). Dissolve 0.125 g of high-purity nickel in 20 ml of H₂SO₄ (1:3) by heating. Cool, transfer the solution to a 250-ml volumetric flask, dilute to the mark with water, and mix.

(b) Standard nickel solution (B) (1 ml = 0.05 mg of Ni). Transfer 10 ml of standard nickel solution (A) with a pipet to a 100-ml volumetric flask, dilute to the mark with water, and mix.

(c) Boric acid solution (0.85 Molar). Dissolve 26.3 g of H_3BO_3 in 400 ml of hot water, cool to room temperature, and dilute to 500 ml.

(d) Citric acid solution (100 g per liter). Dissolve 100 g of citric acid in 900 ml of water, add 10 ml of H_2SO_4 (1:1), and dilute to 1 liter.

(e) Bromine water (saturated).

(f) Alcohol solution of dimethylglyoxime (10 g per liter). Dissolve 2 g of dimethylglyoxime in 150 ml of ethanol in a 250-ml beaker and filter into a 200-ml volumetric flask. Dilute the filtrate to the mark with ethanol and mix.

Preparation of a Calibration Curve

(a) Transfer 0, 1.0, 2.0, 3.0, 4.0, 5.0 and 6.0-ml aliquot portions of standard nickel solution (B) to seven 150-ml beakers. Dilute to about 30 ml with water and add 10 ml of citric acid solution.

(b) Stir, and adjust the pH of the solution to 1.5 with NH_4OH , using a pH meter. Transfer the solution to a 100-ml volumetric flask, washing the beaker 3 times with 2-ml portions of water. Cool in an ice bath. Add 5 ml of bromine water, 5 ml of boric acid solution, enough

NH_4OH (1:1) to just bleach the bromine, and 10 ml of NH_4OH (1:1) in excess, swirling the flask between additions. Cool in an ice bath, remove the flask, add 3.0 ml of dimethylglyoxime solution, and mix. Dilute to the mark with water and mix.

(c) Transfer a suitable portion to a 2-cm absorption cell, and 30 minutes after adding the dimethylglyoxime, measure the transmittance or absorbance at about 540 $\text{m}\mu$, using water for 100 percent transmittance or zero absorbance. Plot the values obtained against milligrams of nickel in 100 ml.*

Procedure

(a) Transfer an aliquot portion (containing 0.015 to 0.30 mg of Ni) of the electrolyte (B) with a pipet to a 150-ml beaker and adjust the volume to about 30 ml by the addition of water or by evaporation, if necessary. Add 10 ml of the citric acid solution and proceed as directed in sections (b) and (c) in preparation of the calibration curve.

(b) Using the value obtained, read from the calibration curve the number of milligrams of nickel present in 100 ml of the solution.

(c) Carry a blank through the entire procedure used for the analysis sample.

* Plot absorbance A, against the respective concentrations on ordinary graph paper; or concentration C, against percentage transmission on semi-logarithmic paper using the semi-log scale for the percentage T values.

Calculation

Calculate the percentage of nickel as follows:

$$\text{Nickel, percent} = \frac{A - B}{C \times 10}$$

Where:

A = mg of Ni in 100 ml of the solution,

B = mg of Ni in 100 ml of the blank, and

C = g of sample in 100 ml of solution.

6. ZINC IN COPPER-BASE STANDARDS

The most desirable method for the accurate determination of zinc is its precipitation as sulfide in dilute sulfuric or formic acid solution, conversion to the oxide, and weighing. The precipitation of zinc with diammonium phosphate followed by ignition to the pyrophosphate is a good method but has the drawbacks that the solution must be free of elements that form insoluble phosphates and must not contain an appreciable amount of alkali salts. The precipitation of zinc as zinc mercuric thiocyanate is useful for determinations of 1 to 100 mg of zinc provided interferers like copper, ferrous iron, cobalt, nickel, manganese, bismuth, and cadmium are absent. Titrimetric procedures are not so accurate for zinc as the gravimetric. The ferrocyanide-titration method is empirical. Zinc may be titrated with the sodium salt of ethylenediaminetetraacetic acid (EDTA) at pH 10, using eriochrome Black T as an indicator, but copper and nickel interfere.

Cartridge Brass, Free-Cutting Brass, Naval Brass,
Red Brass, Gilding Metal, Commercial
Bronze and Aluminum Brass

Method: Sulfide-Oxide-Gravimetric

Scope

This method is recommended for the determination of zinc in the range of 3 to 41 percent. The standard deviation at the high range is 0.08 percent and at the low range 0.03 percent.

Principle of Method

Zinc in a weakly acid solution is precipitated with hydrogen sulfide and zinc sulfide is ignited to the oxide.

Interferences

Antimony, arsenic, and tin are removed by volatilization with hydrobromic acid; copper, lead, and silver are separated by electrolysis; bismuth is removed with hydrogen sulfide, and silicon is separated by dehydration with sulfuric acid before the precipitation of zinc sulfide.

Apparatus

Muffle furnace.

Reagents

(a) Ammonium hydroxide (1:1). One volume of NH_4OH (sp gr 0.9) diluted with an equal volume of water.

(b) Sulfuric acid (1 N). Add 28.5 ml of H_2SO_4 (sp gr 1.84) to 900 ml of water, mix, cool, and dilute to a liter in a volumetric flask. Standardize volumetrically with normal NaOH or gravimetrically with BaCl_2 . Dilute the acid solution with water to exactly 1 Normal as required.

(c) Sulfuric acid (1:1). One volume of H_2SO_4 (sp gr 1.84) diluted with an equal volume of water.

(d) Hydrogen sulfide. Compressed gas or a Kipp generator.

(e) Hydrogen sulfide wash solution. Add 10 ml of H_2SO_4 (sp gr 1.84) to 1 liter of water and saturate with H_2S .

(f) Methyl orange indicator solution. Dissolve 0.02 g of the sulfonic acid in 100 ml of hot water, let the solution cool, and filter if a precipitate separates.

Procedure

(a) Transfer a 50-ml aliquot portion* (= 0.5 g sample) of the electrolyte (B) with a calibrated pipet to a 400-ml beaker for cartridge brass, free-cutting brass and naval brass. Add 20 ml of H_2SO_4 (1:1) and evaporate to dense white fumes of H_2SO_4 . Cool, wash the wall of the beaker with about 10 ml of water, mix and evaporate until fumes of H_2SO_4 appear. Cool, dilute to about 300 ml with water, and warm to dissolve salts, if necessary. Cool to room temperature and treat the solution with H_2S for 30 minutes to precipitate residual copper. Allow the precipitate to settle and filter through a fine paper. Wash with H_2SO_4 (1:99) saturated with H_2S . Discard the paper and contents.

(b) Boil the filtrate and washings for 30 minutes. Cool, add 2 drops of methyl orange indicator solution, and neutralize with NH_4OH (1:1). Add 0.9 ml of N H_2SO_4 for each 100 ml volume of solution and cool to room temperature. Precipitate the zinc as sulfide,

* Use 100-ml aliquot portion (= 1 g sample) for red brass, gilding metal, commercial bronze and aluminum brass.

using a rapid stream of H_2S for 30 minutes. Allow the precipitate to settle and filter through a tight paper. Wash with cold water. Place the paper and contents in a weighed porcelain crucible and ignite slowly in an oxidizing atmosphere until all the carbon is destroyed. Gradually increase the temperature to 950° to $1000^\circ C$, and heat at this temperature for about 25 minutes. Cool in a desiccator and weigh as ZnO . Correct for a blank carried through all steps of the determination.

(c) If it is desirable to precipitate zinc with H_2S twice, place the first ZnS precipitate and paper in the original beaker. Cautiously add 10 ml of H_2SO_4 (sp gr 1.84) and 25 ml of HNO_3 (sp gr 1.42) and evaporate until fumes of H_2SO_4 appear. Cool, repeat the addition of HNO_3 and the evaporation to fumes of H_2SO_4 until organic matter is destroyed. Cool, add about 10 ml of water cautiously, and evaporate to fumes of H_2SO_4 again. Cool, dilute to about 100 ml with water, and digest on a steam bath to dissolve the salts. Filter the solution through a tight 9-cm paper and wash with hot H_2SO_4 (1:99). Dilute the filtrate to at least 100 ml volume for each 0.1 g of zinc present, add methyl orange indicator, neutralize with NH_4OH , add N H_2SO_4 , and treat with H_2S as directed before. Filter

through a fine paper and wash with cold water. Place the paper and contents in a weighed porcelain crucible, ignite, cool, and weigh as directed before.

Calculation

Calculate the percentage of zinc as follows:

$$\text{Zinc, percent} = \frac{(A-B) (0.8034) \times 100}{C}$$

where:

A = grams of ZnO,

B = grams of blank, and

C = grams of sample used.

7. ALUMINUM IN COPPER-BASE STANDARDS

The determination of very small amounts (less than 0.1 mg) of aluminum is difficult because distinctive reactions for aluminum are not common. The determination is often made colorimetrically with the dye aurintricarboxylic acid, which forms a bright red lake with aluminum in faintly acid solutions buffered with acetic acid and acetate salts. The aurin dye is not specific for aluminum and interferers include iron, beryllium, copper, chromium, silicon, metaphosphates, and fluorides. The aurin-photometric method is used for the determination of aluminum in the cartridge and naval brass samples after separation of the bulk of other elements by electrodeposition in a mercury cathode cell.

The yellow solution of aluminum 8-hydroxyquinolate in chloroform is useful for the colorimetric determination of trace amounts of aluminum. The red-violet lake aluminum forms with the dye, Eriochrome cyanine-R, is another. A very sensitive reaction for aluminum is the formation of a lake with Pontachrome Blue Black R which gives a red fluorescence.

Cartridge Brass and Naval Brass

Method: Aluminon-Photometric

Scope

This method is recommended for the determination of aluminum in the range of 0.001 to 0.1 percent. The

standard deviation at the high range is 0.005 percent and at the low range 0.0005 percent.

Principle of Method

After the removal of interfering elements by mercury cathode separation and cupferron extraction, aluminum is determined photometrically at 537 m μ by forming a red lake in a weakly acid solution with aluminon (ammonium aurintricarboxylate).

Interferences

Iron, beryllium, silicon, copper, chromium, metaphosphates, and fluorides interfere in this method. Electrolysis with a mercury cathode in dilute sulfuric or dilute perchloric acid solutions causes such elements as chromium, iron, copper, nickel, zinc, silver, tin, and bismuth to deposit in the mercury cathode. Residual iron, titanium, and vanadium are extracted as cupferrates with chloroform. All of the commonly encountered interfering elements are removed in this procedure. The method is not suitable for alloys containing beryllium or appreciable amounts of vanadium.

Concentration Range

The recommended concentration range is from 0.01 to 0.09 mg of aluminum in 100 ml of solution, using a cell depth of 2 cm.

Stability of Color

The color is stable for at least 30 minutes.

Apparatus

(a) Mercury cathode cell. A mercury cathode cell capable of operating up to 15 amperes is used to electrolyze the solutions.

(b) Colorimeter. Spectrophotometer with matched cells is used.

Reagents

(a) Cupferron solution (60 g/liter). Dissolve 6 g of cupferron in 100 ml of cold water and filter. Prepare freshly as needed.

(b) Thioglycolic acid solution (100 ml/l). Dilute 10 ml of thioglycolic acid to 100 ml with water and filter, if necessary. This solution is stable for 1 week.

(c) Aluminon-buffer composite solution. Dissolve 125 g of ammonium acetate in 250 ml of water and add 20 ml of glacial acetic acid. Filter through a fine paper. While stirring this filtrate well, add, first, a solution of 0.250 g of aluminon (ammonium aurintricarboxylate) dissolved in 50 ml of water, followed by a solution of 0.5 g of benzoic acid dissolved in 20 ml of methanol. Dilute the mixture to 500 ml, add 250 ml of glycerol, and stir well. Use a pH meter and

adjust the pH of the mixture to 5.5 with acetic acid or ammonium acetate. Store in a dark glass-stoppered bottle.

(d) Standard aluminum solution (A) (1 ml = 1.00 mg of Al). Transfer 1.000 g of high-purity aluminum to a liter volumetric flask. Add 50 ml of HCl (1:1) and heat gently until the metal is dissolved. Cool to room temperature, dilute to the mark, and mix.

(e) Standard aluminum solution (B) (1 ml = 0.01 mg of Al). Transfer exactly 10 ml of standard aluminum solution (A) to a liter volumetric flask, add 10 ml of HCl, dilute to the mark, and mix.

(f) Dinitrophenol indicator (0.2 g/liter). Dissolve 20 mg of 2,4-dinitrophenol in 100 ml of water.

Preparation of Calibration Curve

(a) Transfer 0.0, 1.0, 3.0, 5.0, 7.0, and 9.0 ml of the standard aluminum solution (B) to six 100-ml volumetric flasks. Add 5 drops of HClO_4 (70%) to each flask.

(b) Dilute to 20 ml. Add 3 drops of dinitrophenol indicator to each flask and add NH_4OH dropwise while twirling the solution until the indicator turns yellow. Immediately, add HCl (1:1) dropwise until the solution is colorless and add 1 drop in excess. Add 2 ml of the thioglycolic acid solution and 15.0 ml of the aluminon-buffer composite solution. Place each flask

in a 400-ml beaker containing boiling water. Heat for exactly 4 min. while maintaining the boiling temperature. Remove from the heat and let stand for 1 minute. Cool in running water for 4 min., dilute nearly to the mark, and let stand in water at room temperature for 20 minutes. Dilute to the mark and mix.

(c) Transfer a suitable portion to a 2-cm absorption cell and measure the transmittance or absorbance at about 537 m μ , using water as a reference solution for 100 percent transmittance or zero absorbance. Plot the values obtained against milligrams of aluminum per 100 ml of solution.*

Procedure

(a) Transfer a 100-ml aliquot portion** (containing 1 g of the sample) of the 500 ml solution of the electrolyte (B) to a 250-ml beaker for cartridge brass.

(b) Add 10 ml of HClO₄ (70%) and evaporate to fumes of HClO₄. Cover the beaker and continue heating for 10 minutes. Cool, add 10 ml of water, and evaporate to fumes of HClO₄. Cool, dilute to 100 ml, and transfer the solution to a mercury cathode cell

* Plot absorbance A, against the respective concentrations on ordinary graph paper; or concentration C, against percentage transmission on semi-logarithmic paper using the semi-log scale for the percentage T values.

** For Naval brass use 50-ml aliquot portion (=0.5 g sample) of the electrolyte of sample 1106 or 10 ml of sample 1107, or 15 ml of sample 1108.

containing 35 ml of mercury. Wash with water and add 5 ml of H_2SO_4 (1:1). Electrolyze with a current of 15 amperes for 1/2 hour or until the solution is colorless and then for 15 min. longer. Remove the electrolyte from the cell and wash the electrodes and cell with H_2SO_4 (1:99). Filter the electrolyte and washings through a medium paper and wash 5 times with H_2SO_4 (1:99). Add 25 ml of HCl (sp gr 1.18) to the filtrate and cool to room temperature.

(c) Transfer the solution to a 250-ml separatory funnel, add 5 ml of cupferron solution, mix, and allow to stand for a few minutes. Add 25 ml of CHCl_3 and shake vigorously for 1 minute. Allow the layers to separate and then drain off and discard the lower layer. Wash the solution free of cupferron by extracting at least 4 times with 5-ml portions of CHCl_3 . Transfer the aqueous portion to a 400-ml beaker and heat to boiling to expel CHCl_3 . Add 15 ml of HNO_3 and evaporate the solution to fumes of HClO_4 . Cover the beaker and continue heating for 10 minutes. Cool, add 10 ml of water, and heat. Transfer the solution to a 100-ml beaker and evaporate to copious fumes of HClO_4 and to a volume of less than 1 ml. Cool, add 10 ml of water, and heat. Transfer the solution to a 100-ml volumetric flask and wash twice with 5-ml portions of water.

(d) Proceed as directed in Sections (b) and (c) in preparation of the calibration curve.

(e) Using the value obtained, read from the calibration curve the number of milligrams of aluminum present in 100 ml of solution.

(f) Carry a blank through the entire procedure used for the analysis sample.

Calculation

Calculate the percentage of aluminum as follows:

$$\text{Aluminum, percent} = \frac{A - B}{C \times 10}$$

where:

A = mg of Al in 100 ml of the final solution,

B = mg of Al in 100 ml of the blank, and

C = g of sample used.

Aluminum Brass

Method: Cyanide-8-Hydroxyquinoline-Gravimetric.

Scope

This method is recommended for the determination of aluminum in the range of 1 to 3 percent. The relative standard deviation at this range is 0.02 percent.

Principle of Method

Aluminum is precipitated quantitatively with 8-hydroxyquinoline in an ammoniacal solution containing ammonium citrate, hydrogen peroxide, and sodium cyanide, and determined gravimetrically.

Interferences

Precipitation of aluminum with 8-hydroxyquinoline in ammoniacal solution separates it from phosphorus, arsenic, fluorine, and boron; from titanium, vanadium, chromium, molybdenum, tantalum, and niobium if made in ammoniacal solutions containing hydrogen peroxide; and from iron, copper, cobalt, nickel, and zinc that form complex ions with cyanide in ammoniacal solution containing alkali cyanide.

Apparatus

Fritted-glass crucibles.

Reagents

(a) Citric acid solution (500 g/liter). Dissolve 50 g of citric acid monohydrate in 50 ml of warm H_2SO_4 (1:49), dilute to 100 ml, and filter. Do not wash.

(b) 8-Hydroxyquinoline solution (75 g/l. of ethanol). Dissolve 7.5 g of 8-hydroxyquinoline in 90 ml of ethanol, dilute to 100 ml with ethanol, and filter.

(c) Cyanide solution (400 g/liter). Dissolve 40 g of NaCN in 50 ml of warm water, dilute to 100 ml and filter.

(d) Hydrogen peroxide (3%).

(e) Wash solution (2% each of ammonium tartrate, sodium cyanide, and ammonium chloride in water).

Procedure

(a) Transfer a 100 ml aliquot portion (= 1 g of sample) of the 500 ml solution of the reserved electrolyte (B) with a calibrated pipet to a 600-ml beaker. Add 5 ml of HCl (sp gr 1.18), 5 ml of the citric acid solution, and stir. Dilute the solution to 350 ml with water, add 10 ml of H₂O₂ (3%), and stir. Neutralize the solution with NH₄OH (litmus) and add 10 ml in excess. Add 12.5 ml (5 g) of NaCN solution, stir, and heat the solution to 55° to 60°C. Remove from the heat and slowly add sufficient 8-hydroxyquinoline solution (ethanol) while stirring the aluminum solution vigorously. (Use 0.22 ml of ethanol solution of 8-hydroxyquinoline per mg of aluminum plus 2 ml excess) (use only 2 ml of the solution for a blank). Stir the solution vigorously for 15 minutes and let stand on top of a steam bath for 15 minutes. Cool the solution to room temperature and filter the precipitate onto a weighed, close-fritted glass crucible. Wash 8 to 10 times with the cool wash solution, then with 5 to 10 ml of hot water (75°C) and finally with cold water until the washings are colorless.

(b) Dry the crucible and precipitate at 135°C for 1.5 hours, cool in a desiccator for 1 hour, and weigh. Dry, cool, and weigh as directed before.

Calculation

Calculate the percentage of aluminum as follows:

$$\text{Aluminum, percent} = \frac{(A-B) \times 0.0587}{C} \times 100$$

where:

A = grams of aluminum oxyquinolate found in the aliquot used,

B = grams of aluminum oxyquinolate in the blank and

C = grams of sample represented in the aliquot used.

8. PHOSPHORUS IN COPPER-BASE STANDARDS

One of the most important methods for the colorimetric determination of phosphorus employs the phosphomolybdenum blue complex. The method is based on the measurement of the intensity of blue color which develops when a heteropoly acid formed by phosphate and molybdate is reduced with hydrazine sulfate, hydroquinone, ferrous sulfate, or sodium bisulfite. Interferers are silicon, arsenic, and germanium because they form yellow heteropoly acids which yield a blue color on reduction. Arsenic and germanium can be volatilized by fuming with hydrochloric and hydrobromic acids.

Another good colorimetric method for phosphorus is the phosphovanadomolybdate method which is based on the formation of a yellow-colored complex. The sensitivity of the molybdenum blue method is greater than that of the phosphovanadomolybdate method.

Cartridge Brass, Free-Cutting Brass, Naval Brass,
Red Brass, Gilding Metal, Commercial
Bronze and Aluminum Brass

Method: Molybdenum Blue-Photometric

Scope

This method is recommended for the determination of phosphorus in the range of 0.001 to 0.12 percent. The standard deviation at the high range is 0.005 percent and at the low range 0.0004 percent.

Principle of Method

Phosphorus as the ortho acid forms a blue complex with hydrazine sulfate and ammonium molybdate.

Photometric measurement is made at approximately 650 m μ .

Interferences

Copper (above 15%) and arsenic (above 0.01%) interfere and must be removed.

Concentration Range

The recommended concentration range is from 0.001 to 0.04 mg of phosphorus in 50 ml of solution, using a cell depth of 2 cm.

Stability of Color

The color develops within 5 min. at 95°C and is stable for at least 24 hours. However, a reading is usually made within 30 minutes.

Apparatus

(a) Spectrophotometer and matched absorption cells.

Reagents

(a) Ammonium molybdate solution (2% in 11 N H₂SO₄). Add 300 ml of H₂SO₄ (sp gr 1.84) to 500 ml of water and cool. Dissolve 20 g of ammonium molybdate in the acid and dilute to a liter with water.

(b) Sodium sulfite solution (10%). Dissolve 100 g of anhydrous Na₂SO₃ in 500 ml of water and dilute to a liter. Filter through a tight paper and do not wash.

(c) Hydrazine sulfate solution (0.15%). Dissolve 1.5 g of hydrazine sulfate in 1000 ml of water.

(d) Ammonium molybdate - hydrazine sulfate reagent. Dilute 25 ml of the ammonium molybdate solution to 80 ml with water, add 10 ml of the hydrazine sulfate solution, and dilute to 100 ml with water. This solution is not stable and should be prepared as needed.

(e) Standard phosphorus solution (A) (1 ml = 0.4 mg of P). Dissolve 1.8312 g of Na_2HPO_4 in 200 ml of water, add 35 ml of HNO_3 (1:1), dilute to a liter in a volumetric flask with water, and mix.

(f) Standard phosphorus solution (B) (1 ml = 0.01 mg P). Transfer 5.0 ml of standard phosphorus solution (A) with a pipet to a 200-ml volumetric flask, dilute to the mark with water and mix. Prepare this solution freshly as needed.

Preparation of Calibration Curve

(a) Transfer 0, 0.5, 1.0, 2.0, 3.0, and 4.0-ml aliquot portions of standard phosphorus solution (B) to six 125-ml Erlenmeyer flasks.

(b) Add 5 ml of HNO_3 (1:1) and 3.0 ml of HClO_4 (60%) (or 2.5 ml of HClO_4 (72%)). Evaporate the solution to fumes and fume gently 3 or 4 minutes to remove HNO_3 .

(c) Cool and add 5 ml of HBr (1:4). Evaporate to fuming and fume gently to remove HBr. Cool, wash the wall of the flask with 5 ml of water, and evaporate to fumes. Cool somewhat and add 10 ml of water and 15 ml of Na_2SO_3 solution. Heat the solution to boiling and boil gently for 30 seconds. Add 20 ml of the ammonium molybdate-hydrazine sulfate reagent, heat to about 95°C and heat at this temperature for 4 to 5 minutes. Then heat rapidly just to the boiling temperature but do not boil. Cool rapidly to room temperature and transfer the solution to a 50-ml volumetric flask. Wash the 125-ml flask with 2-ml portions of a dilute solution of the ammonium molybdate-hydrazine sulfate reagent (1:4) and transfer the washings to the 50-ml flask. Dilute to the mark with the diluted solution of the reagent and mix.

(d) Transfer a portion of the solution to a 2-cm absorption cell and measure the transmittance or absorbance at about 650 μ on a spectrophotometer, using water as a reference solution for 100 percent transmittance or zero absorbance. Plot the values obtained against milligrams of phosphorus per 50 ml of solution*. Calculate the phosphorus value in mg per absorption unit from the A-scale readings.

* Plot absorbance A, against the respective concentrations on ordinary graph paper; or concentration C, against percentage transmission on semi-logarithmic paper using the semi-log scale for the percentage T values.

Procedure

(a) Transfer an aliquot portion (containing 0.001 to 0.04 mg of P) of the electrolyte* (B) with a pipet to a 125-ml Erlenmeyer flask. Proceed as directed in sections (b) through (d) in preparation of the calibration curve.

(b) Using the value obtained, read from the calibration curve the number of milligrams of phosphorus present in 50 ml of the final solution.

(c) Carry a blank, s, through all of the operations used for the analysis sample.

Calculation

Calculate the percentage of phosphorus as follows:

$$\text{Phosphorus, percent} = \frac{A - B}{C \times 10}$$

where:

A = mg of P in 50 ml of the final solution,

B = mg of P in 50 ml of the blank, s, and

C = g of sample in 50 ml of the final solution.

* If the electrolyte solution is not available a preliminary separation of phosphorus as ammonium phosphomolybdate is made on a sample of the alloy, the precipitate dissolved in sodium hydroxide, and phosphorus as the ortho acid converted to a blue complex with hydrazine sulfate and ammonium molybdate. Photometric measurement is made at about 650 m μ .

9. TIN IN COPPER-BASE STANDARDS

By far the best method for the determination of tin is that based on its oxidation to the quadrivalent state with standard potassium iodate, after reduction to the bivalent condition in hydrochloric acid solution with granulated lead or nickel. The tin must be completely reduced to the bivalent state and its reoxidation by air prevented before the titration. Interferers include nitric acid, chromium, molybdenum, vanadium, tungsten and copper in amounts greater than 5 milligrams. The iodimetric-titration method is used for the determination of tin in the spectrochemical standard copper-base alloys after two precipitations of quadrivalent tin in the presence of ammonium chloride with ammonium hydroxide, using iron as a gathering agent.

Gravimetric methods for the determination of tin as the dioxide require the separation of elements that would contaminate the weighed product. If tin is precipitated with ammonium hydroxide elements precipitable with ammonium hydroxide must be removed and if tin is precipitated with hydrogen sulfide other elements that are precipitated with hydrogen sulfide must be removed. An excellent procedure for the determination of tin involves its separation by distillation with hydrobromic acid, precipitation with cupferron, and ignition to the oxide.

Colorimetric determinations of tin by the dithiol method or the phenylfluorone method are not entirely satisfactory.

Cartridge Brass, Free-Cutting Brass, Naval Brass
Red Brass, Gilding Metal and Commercial Bronze

Method: Iodimetric-Titration

Scope

This method is recommended for the determination of tin in the range of 0.005 to 1.5 percent. The standard deviation at the high range is 0.03 percent and at the low range 0.001 percent.

Principle of Method

Tin is separated from copper by precipitation with ammonium hydroxide, using iron as a gathering agent, reduced with lead in a hydrochloric acid solution, and titrated with standard potassium iodate.

Interferences

More than 5 mg of copper and 15 mg of antimony interfere; nitric acid, molybdenum, chromium, and vanadium interfere. Oxygen in the air oxidizes bivalent tin.

Apparatus

500-ml Erlenmeyer flask with a two-hole rubber stopper with one hole carrying a syphon outlet tube (7 mm OD glass tubing) slightly constricted at each end and extending from just below the stopper on the inside to about 1 cm from the bottom of the flask on the outside; close the second hole in the stopper with a short length of glass rod.

Reagents

(a) Ammonium chloride wash solution. Dissolve 10 g of NH_4Cl in 1 liter of water and add a few drops of NH_4OH .

(b) Lead. Test lead.

(c) Starch solution. Make a paste of 1 g of soluble starch in about 5 ml of water and add to 100 ml of boiling water. Cool, add a cool solution of 1 g of NaOH in 10 ml of water, then add 5 g of KI, and mix. Prepare freshly as needed.

(d) Tin. High-purity tin (99.95⁺% Sn, NBS SS 42 E)

(e) Standard KIO_3 solution (1 ml = 0.00059 g of Sn). Transfer 0.3567 g of reagent grade KIO_3 to a liter volumetric flask containing 1 g of NaOH and 100 g of KI dissolved in 500 ml of water, and mix. When solution is complete, dilute to the mark, and mix. Standardize the iodate solution as follows: Transfer 0.020 g of the tin to a 500-ml Erlenmeyer flask and add 10 ml of H_2SO_4 (sp gr 1.84). Heat on a hot plate to complete the solution, rotate over a free flame until sulfur is expelled, and cool. Reduce the tin and titrate with KIO_3 as directed in section (c) in the procedure. Carry a blank determination through the same procedure. Calculate the tin equivalent of the KIO_3 solution in grams per milliliter.

Procedure

(a) Transfer 5 g of sample* 1100, or 12 g of sample 1101, or 20 g of sample 1102, and 20 mg of ingot iron (NBS SS 55 d) as FeCl_3 to a 600-ml beaker. Add 30 ml of water, 5 ml of HCl (sp gr 1.18), and 20 ml of HNO_3 (sp gr 1.42) to 5 g of sample; add 50 ml of water, 10 ml of HCl , and 40 ml of HNO_3 to 20 g of sample. Heat on a steam bath, and boil to expel brown fumes. Add 200 ml of water and 5 g of NH_4Cl to 5 g of sample; add 300 ml of water and 10 g of NH_4Cl to 20 g of sample.

(b) Add NH_4OH (1:1) until the basic salts of copper and nickel are dissolved and the solution is deep blue in color. Boil, allow the precipitate to settle, and filter through a medium paper. Wash the beaker and precipitate with the hot NH_4Cl wash solution. Discard the filtrate and place the original beaker under the funnel. Pour 50 ml of the hot HCl (1:1) onto the paper. Wash the paper several times with hot HCl (2:98) and hot water and retain it in the funnel for a second filtration. Dilute the solution to 200 ml, precipitate the tin and iron with NH_4OH , boil, filter, and wash as directed before. Transfer the paper and precipitate to a 500-ml Erlenmeyer flask.

* For free-cutting brass, naval brass, red brass, gilding metal and commercial bronze use a weight of sample that contains from 1 to 20 milligrams of tin.

(c) Add 200 ml of water and 75 ml of HCl (sp gr 1.18). Swirl the flask to break up the paper and to aid solution of the precipitate. Add 10 g of test lead and insert in the flask a two-hole rubber stopper carrying a syphon outlet glass tube and a short length of glass rod. Heat the solution to boiling and boil gently for 30 minutes, avoiding any great decrease in volume. While still boiling, seal the outlet by immersion in a saturated solution of NaHCO_3 prepared from air-free water, remove the flask with seal from the heat, and allow to cool somewhat. Cool to about 10°C in ice water, remove the glass rod from the stopper, and add, through a small funnel, 5 ml of the starch solution. Remove the funnel, insert the buret tip, and titrate with standard KIO_3 solution to a permanent blue tint.

(d) Carry a blank through the entire procedure.

Calculation

Calculate the percentage of tin as follows:

$$\text{Tin, percent} = \frac{(A - B) C \times 100}{D}$$

where:

A = ml of KIO_3 solution required to titrate the sample,

B = ml of KIO_3 solution required to titrate the blank,

C = tin equivalent of the KIO_3 solution in grams per ml, and

D = grams of sample used.

10. MANGANESE IN COPPER-BASE STANDARDS

The periodate-photometric method is one of the best methods for the determination of small amounts of manganese in many materials. The method is based on the formation of the permanganate ion in an acid solution by such oxidation agents as periodate, persulfate, bismuthate, lead dioxide, or argentic oxide. The periodate is to be preferred because the oxidation is reliable, no filtration is required, and the permanganic acid is stable in slight excess of periodate.

Volumetric methods for manganese include the bismuthate-ferrous sulfate method and the persulfate-arsenite-potentiometric method. Interferences in the first method are nitrous or hydrofluoric acid, chlorides, cobalt, and chromium and in the second method chromium in higher amounts.

Precipitation of manganese as manganese ammonium phosphate followed by ignition to the pyrophosphate is the best gravimetric method.

Cartridge Brass and Naval Brass

Method: Potassium Periodate-Photometric

Scope

This method is recommended for the determination of manganese in the range of 0.003 to 0.03 percent. The standard deviation at the high range is 0.002 percent and at the low range 0.0005 percent.

Principle of the Method

Manganese is oxidized to permanganic acid with KIO_4 in a mixture of H_2SO_4 and HNO_3 and is determined photometrically at 525 m μ . The permanganic acid is decolorized with sodium azide and the transmittance or absorbance of the solution is measured again.

Interferences

The elements usually present in copper-base alloys, with the exception of lead, do not interfere. Lead above 0.1% is removed as PbSO_4 by filtration.

Concentration Range

The recommended concentration range is from 0.015 to 0.25 mg of manganese in 100 ml of solution, using a cell depth of 5 cm.

Stability of Color

The permanganate color is stable indefinitely if reducing agents are absent.

Apparatus

Spectrophotometer and matched absorption cells.

Reagents

- (a) Potassium periodate (KIO_4).
- (b) Sodium azide (Na_3N).
- (c) Standard manganese solution (A) (1 ml = 0.5 mg of Mn). Dissolve 0.500 g of electrolytic manganese (99.9% Mn) in a 400-ml beaker with 20 ml of HNO_3 (1:1). Boil until brown fumes have been expelled, cool, dilute

with water to 1 liter in a volumetric flask, and mix.

(d) Standard Manganese solution (B) (1 ml = 0.010 mg of Mn). Transfer 10 ml of standard manganese solution (A) to a 500-ml volumetric flask with a pipet, dilute to the mark with water, and mix. Prepare freshly as needed.

Preparation of Calibration Curve

(a) Transfer 0.5 g of high-purity copper (melting-point SS Cu 45c) to each of six 250-ml beakers. Add 60 ml of H_2SO_4 (1:2) and 5 ml of HNO_3 (sp gr 1.42), cover, and heat on a steam bath until the copper is dissolved. Boil until brown fumes have been expelled. Cool somewhat, and add 0, 2.5, 5.0, 10, 17.5, and 25-ml aliquot portions of standard manganese solution (B) (1 ml = 0.010 mg of Mn) to the 6 copper solutions, respectively. Dilute to about 90 ml with water.

(b) Add 0.5 g of KIO_4 and boil for 5 minutes. Digest on a steam bath for 20 minutes. Cool to room temperature, dilute to 100 ml in a volumetric flask, and mix.

(c) Transfer a suitable portion of the solution to a 5-cm absorption cell and measure the transmittance or absorbance at 525 m μ on a spectrophotometer, using water as reference solution for 100% transmittance or zero absorbance

(d) Add 15 mg of sodium azide to the solution remaining in the volumetric flask and heat on a steam bath 5 or 6 minutes, swirling the solution occasionally. Cool to room temperature and measure the transmittance or absorbance again as directed before.

(e) Subtract the absorbance of the azide-treated solution from the absorbance of the periodate-treated solution and plot the net values obtained against milligrams of manganese per 100 ml of solution.*

Procedure

(a) Transfer 0.5 g of the sample to a 250-ml beaker and cover. Add 80 ml of H_2SO_4 (1:3) and 10 ml of HNO_3 (1:1). Heat on a steam bath until the alloy is dissolved. [If $PbSO_4$ precipitates, it may be separated after boiling the solution, cooling, and filtering through a 7-cm paper. Wash once or twice with a total of 5 ml of HNO_3 (1:99)]. Boil until brown fumes have been expelled. Cool and proceed as directed in sections (b), (c), and (d) in preparation of the calibration curve.

(b) Subtract the absorbance of the azide-treated solution from the absorbance of the periodate-treated solution and using the net value obtained, read from the calibration curve the number of milligrams of manganese in 100 ml of solution.

* Plot absorbance A, against the respective concentrations on ordinary graph paper.

Calculation

Calculate the percentage of manganese as follows:

$$\text{Mn, percent} = \frac{A}{B \times 10}$$

where:

A = mg of Mn in 100 ml of solution, and

B = g of sample in 100 of solution.

11. ARSENIC IN COPPER-BASE STANDARDS

One of the most successful methods for the colorimetric determination of arsenic in nonferrous alloys is that based on the separation of arsenic as the element in a hydrochloric acid solution of the alloy by reduction with sodium hypophosphite, dissolution of the arsenic in iodine, formation of the arsenic-molybdenum blue complex, and measurement of the intensity of color with a spectrophotometer.

Arsenic is usually separated from other elements by distilling it as arsenic trichloride and is then determined by weighing as the sulfide, or by converting the arsenious sulfide to silver arsenate and titrating the silver with potassium thiocyanate, or by titration of the arsenic in the distillate with standard iodine or potassium bromate solution. The hypophosphite method gives a better recovery of arsenic than the distillation procedure.

Cartridge Brass and Aluminum Brass

Method: Hypophosphite-Molybdenum Blue-Photometric

Scope

This method is recommended for the determination of arsenic in the range of 0.005 to 0.12 percent. The standard deviation at the high range is 0.005 percent and at the low range 0.001 percent.

Principle of Method

Arsenic is precipitated with sodium hypophosphite in a hydrochloric acid solution of the sample. The

arsenic is dissolved in an iodine solution and determined by the molybdenum-blue photometric method. Photometric measurement is made at approximately 765 m μ .

Interferences

None

Concentration Range

The recommended concentration range is 0.005 to 0.045 mg of arsenic in 25 ml of solution, using a cell depth of 2 cm.

Stability of Color

The color is stable for at least 24 hours.

Apparatus

Spectrophotometer and matched absorption cells.

Reagents

(a) Standard arsenic solution (A) (1 ml = 1.000 mg As). Dissolve 1.3204 g of NBS standard sample 83b, As₂O₃, in 10 ml of water containing 2 g of KOH. Add H₂SO₄ (1:1) until just acid, using litmus as an indicator. Cool, transfer to a liter volumetric flask, dilute to the mark with water and mix.

(b) Standard arsenic solution (B) (1 ml = 0.010 mg As). Transfer 10.0 ml of standard arsenic solution (A) to a liter volumetric flask. Add 5 ml of H₂SO₄ (1:1), dilute to the mark with water and mix. Prepare freshly as needed.

(c) Sodium hypophosphite (NaH₂PO₂ · H₂O).

(d) Iodine solution (0.02 N). Dissolve 2.54 g of iodine in 25 ml of water containing 8 g of KI. Dilute to 1 liter with water, mix, and store in a cool place in a dark-colored glass-stoppered bottle.

(e) Aerosol (10%).

(f) Ammonium molybdate solution (1% in 5 N H_2SO_4). Add 70 ml of H_2SO_4 (sp gr 1.84) to about 300 ml of water. Dissolve 5 g of ammonium molybdate, $(NH_4)_6Mo_7O_{24} \cdot 4H_2O$, in the warm solution. Cool and dilute to 500 ml with water.

(g) Hydrazine sulfate (0.15%). Dissolve 0.15 g of hydrazine sulfate, $N_2H_4 \cdot H_2SO_4$, in 100 ml of water.

(h) Aqua regia. Add 3 parts of HCl (sp gr 1.18) to 1 part of HNO_3 (sp gr 1.42). Prepare freshly as needed.

Preparation of Calibration Curve

(a) Transfer 0, 0.5, 1.5, 2.5, 3.5, and 4.5-ml aliquot portions of the standard arsenic solution (B), (1 ml = 0.010 mg As), to six 150-ml beakers. Dilute to 25 ml and add 30 ml of HCl (sp gr 1.18). Add 0.5 g of cuprous chloride, Cu_2Cl_2 , and stir until the copper salt is dissolved.

(b) Add 4 g of sodium hypophosphite. Immerse the beaker in a steam bath and stir until the reagent is in solution. Heat for 5 min. while immersed in the

steam bath. Place on top of the steam bath and continue heating the solution for 20 minutes. Remove from the steam bath and boil for 5 minutes to coagulate the arsenic.

(c) Filter immediately through a fine-porosity 10-ml fritted-glass crucible, using moderate suction. Do not fill the crucible more than two-thirds full because the arsenic has a tendency to creep. Wash the beaker three times and then the crucible three additional times with hot, freshly boiled water. Air oxidation of the arsenic should be avoided as much as possible. Replace the filtrate receiver with a 200-ml volumetric flask. Discard the filtrate.

(d) Pour 10 ml of the iodine solution (0.02 N) down the sides of the beaker. Add 1 small drop of aerosol (10%) and stir well. Dissolve the arsenic in the beaker by scrubbing the walls and bottom of the beaker with a rubber policeman. Transfer the iodine solution to the crucible containing the arsenic. Using the policeman as before, dissolve the arsenic in the crucible taking care to scrub the side of the crucible. Apply suction until there is about one drop per second. Stir the iodine solution several times while applying suction. Wash the beaker three times and then the crucible three additional times with water. Full suction may be applied during the washing. Dilute

the arsenic solution in the volumetric flask to the mark with water and mix well.

(e) Transfer a 20-ml aliquot portion with a pipet to a 25-ml volumetric flask. Add 2.5 ml of the ammonium molybdate solution and 1.0 ml of the hydrazine sulfate solution, shaking well after each addition. Dilute to the mark and mix.

(f) Place in a boiling-water bath for 15 minutes. Cool to room temperature.

(g) Transfer a suitable portion of the solution to a 2-cm absorption cell and measure the transmittance or absorbance at approximately 765 m μ , using water as a reference solution for 100 percent transmittance or zero absorbance.

(h) Plot the values obtained against milligrams of arsenic per 25 ml of solution.*

Procedure

(a) Transfer a 1-g sample to a 150-ml beaker, cover, and add 8 ml of aqua regia. Place on the side of the steam bath until the reaction has ceased. Wash the cover, remove, and evaporate just to dryness on a steam bath. Add 5 ml of HCl (sp gr 1.18), cover, and heat on a steam bath until the reaction has ceased. Wash

* Plot absorbance A, against the respective concentrations on ordinary graph paper; or concentration C, against percentage transmission on semi-logarithmic paper using the semi-log scale for the percentage T values.

and remove the cover and again evaporate just to dryness. Add 0.5 g of Cu_2Cl_2 to the blank only. Add 25 ml of water and 30 ml of HCl (sp gr 1.18) and stir until the salts are in solution.

(b) Proceed as directed in sections (b) through (g) in preparation of the calibration curve.

(c) Obtain from the calibration curve the milligrams of arsenic in 25 ml of the final solution.

(d) Carry a blank through all of the operations used for the analysis sample.

Calculation

Calculate the percentage of arsenic as follows:

$$\text{As, percent} = \frac{A - B}{C \times 10}$$

where:

A = mg of As in 25 ml of the final solution

B = mg of As in 25 ml of the blank solution,

and

C = g of sample in 25 ml of the final solution.

* For aluminum brass use a 10-ml aliquot portion of 200 ml of sample 1119 or a 5-ml aliquot portion of sample 1120.

12. SILICON IN COPPER-BASE STANDARDS

An important method for the colorimetric determination of silicon up to 200 parts per million in brass is the molybdenum blue method. Molybdisilicic acid formed in a solution containing hydrofluoric, boric, and molybdic acids of pH 1.7 to 1.8 is extracted with butyl alcohol after addition of tartaric acid and the heteropoly acid is reduced with stannous chloride to the blue complex before measuring the intensity of the color. The addition of tartaric acid stops further reactions of the molybdisilicic acid with the silica from either the reagents or glassware.

Another colorimetric method is the yellow silicomolybdate method but it is not as sensitive as the molybdenum blue procedure.

Gravimetric determination of silicon of such low concentrations by dehydration with acids is not feasible.

Cartridge Brass and Aluminum Brass

Method: Molybdenum Blue-Photometric

Scope

This method is recommended for the determination of silicon in the range of 5 to 200 ppm in brass.

The standard deviation at this range is 0.0001 percent.

Principle of Method

The sample is dissolved in a mixture of diluted sulfuric and nitric acids. After adding hydrofluoric,

boric, and molybdic acids, the pH of the solution is adjusted to 1.7 - 1.8 to form molybdisilicic acid which is extracted with normal butyl alcohol and reduced with stannous chloride to a heteropoly blue complex. The photometric measurement is made at approximately 635 m μ .

Interferences

The elements ordinarily present in brass do not interfere. Solutions should be kept in plastic containers and reagents selected to give a low blank.

Concentration Range

The recommended concentration range is from 5 to 20 μ g of silicon in 50 ml of butyl alcohol, using a cell depth of 2 cm.

Stability of Color

The intensity of the color is stable for at least 1 hour.

Apparatus

- (a) Spectrophotometer with matched absorption cells.
- (b) pH meter.
- (c) Plastic graduated cylinders, plastic pipets, plastic bottles, and plastic beakers.
- (d) Platinum crucibles.

Reagents

(a) Ammonium hydroxide solution. Bubble ammonia gas using plastic tubing, into cooled distilled water in a polyethylene bottle until the solution is saturated.

(b) Boric acid solution (50 g per liter). Dissolve 50 g of H_3BO_3 in 900 ml of warm water, cool, and dilute to 1 liter with water.

(c) Potassium permanganate solution (0.6 g per liter). Dissolve 0.15 g of $KMnO_4$ in 200 ml of water and dilute to 250 ml with water.

(d) Molybdic acid solution. Dissolve 25 g of ammonium molybdate tetrahydrate in 200 ml of H_2SO_4 (1:9) in a 400-ml plastic beaker, dilute to 250 ml with water, and filter through a close-textured paper in a plastic funnel into a polyethylene bottle.

(e) Tartaric acid solution (200 g per liter). Dissolve 50 g of tartaric acid in 200 ml of water and dilute to 250 ml with water.

(f) Stannous chloride reducing solution (20 g per liter). Dissolve 2 g of $SnCl_2 \cdot 2H_2O$ and 1 mg of $CuCl_2 \cdot 2H_2O$ in 100 ml of HCl (sp gr 1.18) and store in a glass-stoppered bottle. This solution should be prepared freshly every 3 days.

(g) Standard silicon solution (A) (1 ml = 200 μ g of Si). Fuse 213.9 mg of SiO_2 with 2 g of Na_2CO_3 in a

platinum crucible, cool, and dissolve the melt in 200 ml of water in a plastic beaker. Transfer the solution to a 500-ml volumetric flask, dilute to the mark with water, mix well, and store the solution in a plastic bottle.

(h) Standard silicon solution (B) (1 ml - 2 μ g of Si). Transfer exactly 10 ml of standard silicon solution (A) to a 1-liter volumetric flask, dilute to the mark with water, mix well, and store in a plastic bottle.

(i) Sulfuric-nitric acid solution mixture (10% H_2SO_4 - 10% HNO_3). Add 50 ml of H_2SO_4 (low in Si), in a plastic graduate, to 300 ml of water in a plastic bottle, mix, and cool. Add 50 ml of HNO_3 (low in Si) to the bottle, dilute to 500 ml with water, and mix. This solution is referred to as 10% H_2SO_4 - 10% HNO_3 solution in the procedure.

(j) Dilute sulfuric acid (1:99).

Preparation of Calibration Curve

(a) Calibration solutions.

(1) Transfer 0.0, 2.5, 5.0, 7.5, and 10.0 ml of standard silicon solution (B) to five covered 250-ml plastic beakers. Add 10 ml of the 10% H_2SO_4 - 10% HNO_3 solution.

(2) Add 0.5 ml of HF, mix, and allow to stand a few minutes. Add 40 ml of the boric acid solution and 4 ml of the molybdic acid solution, mixing after each addition. Add 3 or 4 drops of the potassium

permanganate solution, mixing after each drop. Add 1 or 2 ml of the ammonium hydroxide solution from a plastic tube to neutralize some of the acid before using the glass electrode. Adjust the pH of the solution to 1.7 to 1.8 with the ammonium hydroxide solution. Cover the beaker and heat for 10 minutes on a steam bath. Cool in water at 20°C for 10 minutes. Add 4 ml of the tartaric acid solution and mix thoroughly. Glassware can be used from this point. Transfer the solution to a 250-ml separatory funnel. Wash the beaker twice with water and add the water to the funnel. Dilute the solution to a volume of approximately 90 ml, add 14 ml of H_2SO_4 (1:1), and mix. Cool to room temperature, add 50 ml of normal butyl alcohol, and shake vigorously for 1 minute. Allow the layers to separate, drain, and discard the acid layer. Wash the butyl alcohol layer by adding 20 ml of H_2SO_4 (1:99) to the separatory funnel, shaking for 30 seconds, allowing the layers to separate, draining, and discarding the acid layer. Repeat the washing 2 more times. Transfer the butyl alcohol to a 50-ml volumetric flask. Wash the funnel twice with small portions (1 or 2 ml) of butyl alcohol and add the washings to the volumetric flask. Add 0.5 ml of the stannous chloride reducing solution to the flask, dilute to the mark with butyl alcohol, and mix.

(b) Photometry. Fill the reference cell with normal butyl alcohol and adjust the photometer to the initial setting, using a light band centered at approximately 635 m μ . While maintaining this photometric adjustment, take the photometric readings of the solutions. One or two drops of the stannous chloride reducing solution may be added to the cell, mixed, and another photometric reading taken to check for the complete reduction of the molybdisilicic acid.

(c) Calibration curve. Plot the photometric readings of the calibration solutions against the micrograms of silicon per 50 ml of solution.*

Procedure

(a) Transfer 0.2 g of sample** 1100, or 0.4 g of sample 1101, or 0.5 g of sample 1102, to a plastic covered 250-ml plastic beaker, and add 10 ml of 10% H₂SO₄ - 10% HNO₃ solution from a plastic graduate. Warm the solution to about 75°C on a steam bath for 20 to 30 minutes or until the sample dissolves. Warm for 30 minutes more to expel nitrous fumes, cool, and continue as directed in sections (a) (2) and (b) in the preparation of the calibration curve.

* Plot absorbance A, against the respective concentrations on ordinary graph paper; or concentration C, against percentage transmission on semi-logarithmic paper using the semi-log scale for the percentage T values.

** Use 0.5 g sample of aluminum brass or for samples containing more than 40 ppm of silicon use a sample weight that contains less than 20 μ g of silicon.

(b) Carry through a reagent blank following the same procedure and using the same quantity of all reagents.

(c) By means of the calibration curve, convert the photometric readings of the sample solutions to micrograms of silicon.

Calculation

Calculate the percentage of silicon as follows:

$$\text{Si, percent} = \frac{A - B}{C \times 10^4}$$

where:

A = μg of Si found in the 50 ml of butyl alcohol extract of the sample

B = μg of Si found in the 50 ml of butyl alcohol extract of the blank

C = g of sample represented in the 50 ml of butyl alcohol extract of the sample.

13. ANTIMONY IN COPPER-BASE STANDARDS

An accurate method for the determination of antimony in the amount of a few milligrams is that in which the element is oxidized from the trivalent to the quinquevalent state in hydrochloric acid solution with a standard solution of potassium bromate. Arsenic is the chief interfering element but it is separated from antimony by distillation.

Gravimetric methods for antimony are troublesome and more subject to errors than titrimetric methods. Electrolytic deposition tends to give high results.

Colorimetric methods for antimony include the rhodamine B method, the iodide method, and the phosphomolybdic acid method. In hydrochloric acid medium, quinquevalent antimony reacts with rhodamine B to give insoluble red-violet rhodamine B chloroantimonate. In acid solution, iodide in excess yields iodoantimonite ion with antimony, which has a strong yellow color. Trivalent antimony reduces phosphomolybdic acid to soluble blue compounds.

Cartridge Brass and Aluminum Brass

Method: Distillation-Bromate.

Scope

This method is recommended for the determination of antimony in the range of 0.005 to 0.15 percent. The standard deviation at the high range is 0.005 and at the low range 0.001 percent.

Principle of Method

Antimony is separated from most of the copper and zinc by precipitation in an ammoniacal solution, using iron as a gathering agent, distilled with hydrochloric acid and titrated with standard potassium bromate solution.

Interferences

Arsenic interferes with the determination of antimony but is separated in this method.

Apparatus

All-glass still, figure 1.

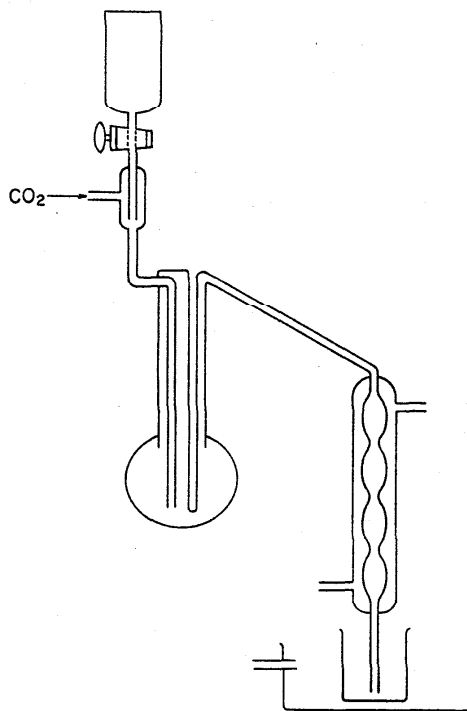

Figure 1. All-glass still used for the determination of antimony in standard copper-base materials.

Reagents

(a) High-purity iron (less than 0.001% Sb).

(b) Methyl orange indicator solution (0.2 g per l.). Dissolve 0.02 g of methyl orange in 100 ml of hot water. Filter if necessary.

(c) Standard antimony solution (1 ml = 1.0 mg of Sb). Transfer 0.200 g of high-purity antimony to a 300-ml Erlenmeyer flask and add 5 ml of H_2SO_4 (sp gr 1.84). Rotate the flask while heating over a free flame and, after solution of the metal, heat to fumes of H_2SO_4 to expel the sulfur. Cool, add 5 ml of water, and cool again. Add 20 ml of HCl (1:1), mix, and transfer the solution to a 200-ml volumetric flask. Rinse the Erlenmeyer flask 4 times with 15 ml portions of HCl (1:1) and once with water and add the washings to the volumetric flask. Dilute to the mark with water and mix.

(d) Standard $KBrO_3$ solution (about 0.01 N). Dissolve 0.2784 g of reagent grade $KBrO_3$ in water and dilute to 1 liter in a volumetric flask. Standardization: Add 150 ml of water and 15 ml of HCl (sp gr 1.18) to a 400-ml beaker. Add 2.0 ml (= 2.0 mg of Sb) of the standard antimony solution and heat the solution to 80°C. Titrate the hot solution with $KBrO_3$ solution, using 2 drops of methyl orange as indicator, which should preferably be added near the end of the titration, to the disappearance of the red color.

Make a blank determination, following the same procedure and using the same amount of all reagents except the added antimony solution.

Procedure

(a) Transfer 12.5 g^{*} of sample 1100, or 25 g of 1101, or 50 g of 1102, and 0.275 g of iron (low in As and Sb) to an 800-ml beaker. Add 50 ml of water, 10 ml of HCl (sp gr 1.18), and 40 ml of HNO₃ (sp gr 1.42) to the beaker containing sample 1100; add 100 ml of water, 20 ml of HCl and 80 ml of HNO₃ to sample 1101; and add 200 ml of water, 40 ml of HCl, and 160 ml of HNO₃ to sample 1102. Carry a blank containing 0.275 g of the iron through the entire procedure. Heat on the side of a steam bath, and after action ceases, heat to boiling and boil for 1 or 2 minutes. Dilute to about 400 ml with hot water. Neutralize with NH₄OH and add an excess of several ml as indicated by the deep blue color of the solution. Heat to boiling and boil for about 1 minute. Digest on a steam bath and allow the precipitate to settle.

(b) Filter the hot solution through a 15-cm medium paper and wash 3 or 4 times with hot NH₄OH (1:9). Discard the filtrate and washings. Carefully remove the paper and contents from the funnel, open the paper on the inside wall of the original beaker and wash the

* For aluminum brass use 25 g of sample 1118, or 8 g of sample 1119, or 3 g of sample 1120.

bulk of the precipitate off the paper with hot water. Return the paper to the funnel and reserve for the second filtration.

(c) Add 40 ml of HNO_3 (1:1) to the beaker, heat, and stir until the precipitate has dissolved. Dilute to about 300 ml with hot water, add NH_4OH , heat, filter, and wash as directed before. Discard the filtrate.

(d) Place the paper and contents in a 500-ml Kjeldahl flask and add about 12 ml of H_2SO_4 (sp gr 1.84). Warm to char the paper, cool, and add 25 ml of HNO_3 (sp gr 1.42). Mix, and digest on a steam bath. Evaporate to fumes of H_2SO_4 while rotating the flask over a free flame. Cool somewhat and add 10 ml of HNO_3 slowly. Evaporate until fumes of H_2SO_4 appear. Repeat the addition of HNO_3 and the evaporation, if necessary, until the organic matter is destroyed. Cool, add 10 ml of water and evaporate until fumes of H_2SO_4 appear. Cool somewhat and add 0.2 g of sublimed sulfur (flowers of sulfur). Heat while boiling the H_2SO_4 for about 5 minutes to assure reduction of arsenic and antimony. Cool, add 35 ml of water, and heat while boiling until the volume of the solution is reduced to about 20 ml. Add 35 ml of water and

boil again to a volume of about 20 ml to remove SO_2 . Cool, add 15 ml of water, cool again, add 10 ml of HCl (sp gr 1.18), and mix. Filter the solution through a 7-cm medium texture paper into an all-glass still (figure 1). Wash the Kjeldahl flask 6 times with 10 ml portions of HCl (1:1) and pour onto the filter. Wash once with water. Remove the funnel and add 20 ml of HCl (sp gr 1.18) to the still.

(e) Place a 600-ml beaker containing 150 ml of water below the condenser and pass a stream of CO_2 gas through the still at a rate of 6 to 8 bubbles per second. Heat the solution to boiling and boil gently at 110 to 111°C until the volume of the solution in the still has been reduced to about 50 ml. Add 100 ml of HCl (sp gr 1.18) to the still, heat to 110-111°C, and distill at this temperature until the volume has been reduced to about 50 ml again. Lower the distillate without interrupting the stream of CO_2 or the heating and wash the end of the condenser with water. Reserve the distillate (A) for the determination of arsenic, if desirable, and place a 600-ml beaker containing 160 ml of water under the condenser.

(f) Add 7 ml of H_3PO_4 (85%) to the still, reduce the flow of CO_2 somewhat, and increase the heat until the temperature in the flask reaches 155°C. Add 100 ml

of HCl (sp gr 1.18) dropwise at a rate of 30 to 40 drops a minute while maintaining the temperature at $160^{\circ}\text{C} \pm 5$. When all the antimony has been distilled, discontinue the heating, lower the receiver, wash the condenser tip, and reserve distillate (B) for the determination of antimony.

(g) Dilute the reserved Sb distillate (B) to 525 ml and heat the solution to 80°C . Titrate the hot solution with standard KBrO_3 , using 2 drops of methyl orange as indicator, which should be added near the end of the titration, to the disappearance of the red color.

(h) Titrate the blank following the same procedure used for the analysis sample.

Calculation

Calculate the percentage of antimony as follows:

$$\text{Antimony, percent} = \frac{(A - B) \times C \times 100}{D}$$

where:

A = ml of KBrO_3 solution used to titrate the sample,

B = ml of KBrO_3 solution used to titrate the blank,

C = antimony titer of the KBrO_3 solution in g,

and

D = grams of sample used.

14. REFERENCES

- [1] Am. Soc. for Metals, "Metals Handbook", 1948 edition, The Am. Soc. for Metals, Cleveland, Ohio.
- [2] Michaelis, R.E., Wyman, L.L., and Flitsch, R., "Standard Reference Materials: Preparation of NBS Copper-Base Spectrochemical Standards", NBS Misc. Publ. 260-2, October 1964.
- [3] Hillebrand, Lundell, Bright and Hoffman, "Applied Inorganic Analysis", 2nd edition, John Wiley and Sons, Inc., New York, 1953.
- [4] Scherrer, Bell and Mogerman, "Electroanalytical Determination of Copper and Lead in Nitric Acid Solution Containing Small Amounts of Hydrochloric Acid", J. Res. Natl. Bur. Std. 22, 697 (1939).
- [5] Scherrer, J.A., "Determination of Arsenic, Antimony and Tin in Lead-, Tin-, and Copper-Base Alloys", J. Res. Natl. Bur. Std. 21, 95 (1938).
- [6] Kolthoff, I.M., Elving, P.J. and Sandell, E.B., "Treatise on Analytical Chemistry", Part II, Vol. 6, Interscience, New York, 1964.
- [7] Smith, E.F., "Electroanalysis", 6th edition, P. Blakistons Sons & Co., Philadelphia, Pa., 1918.

Additional References

- [1] Am. Soc. Testing Materials, Philadelphia, "1965 Book of ASTM Standards", Part 32, 1965.
- [2] Bell, R.K. and Machlan, L.A., "Silicon in Brasses by the Butyl Alcohol Extraction-Molybdenum Blue-Photometric Method", Unpublished Paper (1962).
- [3] Boltz, D.F., "Colorimetric Determination of Nonmetals", Interscience, New York, 1958, p. 29.
- [4] Boltz, D.F. and Mellon, M.G., "Determination of Phosphorus, Germanium, Silicon, and Arsenic by the Heteropoly Blue Method", Ind. & Eng. Chem., Anal. Ed., 19, 873 (1947).

- [5] Cartwright, W., Collier, T.W. and Charlesworth, A., "The Analysis of Nonferrous Metals and Alloys", Lippincott, New York, 1937.
- [6] Case, O.P., "Direct Photometric Determination of Silicon in Copper-Base Alloys, Anal. Chem., 16, 309 (1944).
- [7] Case, O.P., "Photometric Determination of Arsenic in Copper and Copper-Base Alloys", Anal. Chem., 20, 902 (1948).
- [8] Clabaugh, W.S., Jackson, A., "Separation and Determination of Phosphate, Silicate, and Arsenate", J. Res. Natl. Bur. Std. 62, 201 (1959).
- [9] Classen, A. and Danneel, H., "Quantitative Analyse durch Electrolyse", 7th edition, J. Springer, Berlin, 1927.
- [10] Dozinell, C.M., "Modern Methods of Analysis of Copper and its Alloys", 2nd edition, Elsevier, Amsterdam, 1963.
- [11] Fales, H.A. and Ware, G.M., "A Study of Conditions Affecting the Precise Determination of Zinc as the Sulfide", J. Am. Chem. Soc., 41, 487 (1919).
- [12] Fortune, W.B. and Mellon, M.G., "Determination of Iron with o-phenanthroline", Ind. & Eng. Chem., Anal. Ed., 10, 60 (1938).
- [13] Furman, N.H., Editor, "Scott's Standard Methods for Chemical Analysis", 5th edition, D. Van Nostrand, Princeton, N.J., 1939.
- [14] Hague, J.L. and Bright, H.A., "Colorimetric Determination of Phosphorus in Steel and Cast Iron", J. Res. Natl. Bur. Std., 26, 405 (1941).
- [15] Hague, J.L., Brown, E.D. and Bright, H.A., "Photometric Determination of Copper in Iron and Steel with Diethyldithiocarbamate", J. Res. Natl. Bur. Std. 47, 380 (1951).
- [16] Hummel, F.C., Willard, H.H., "Use of o-phenanthroline in the Determination of Iron in Biological Materials", Ind. & Eng. Chem., Anal. Ed., 10, 13 (1938).

- [17] Kolthoff, I.M., Elving, P.J. and Sandell, E.B., "Treatise on Analytical Chemistry", Part II, Vol. 7, Interscience, New York, 1961.
- [18] Kolthoff, I.M., Elving, P.J. and Sandell, E.B., "Treatise on Analytical Chemistry", Part II, Vol. 5, Interscience, New York, 1961.
- [19] Kolthoff, I.M., Elving, P.J. and Sandell, E.B., "Treatise on Analytical Chemistry", Part II, Vol. 3, Interscience, New York, 1961.
- [20] Kolthoff, I.M., Elving, P.J. and Sandell, E.B., "Treatise on Analytical Chemistry", Part II, Vol. 2, Interscience, New York, 1962.
- [21] Low, A.H., Weinig, A.J. and Schoder, W.P., "Technical Methods of Ore Analysis", 11th edition, John Wiley and Sons, Inc., New York, 1939, p. 239.
- [22] Mitchell, A.M. and Mellon, M.G., "Colorimetric Determination of Nickel with Dimethylglyoxime", Ind. & Eng. Chem., Anal. Ed., 17, 380 (1945).
- [23] Morrison, I.R. and Wilson, A.L., "The Absorptiometric Determination of Silicon in Water", The Analyst, 88, Part I, 88 (1963); The Analyst, 88, Part II, 100 (1963); The Analyst, 88, Part III, 446 (1963).
- [24] Morrison, G.H., Freiser, H., "Solvent Extraction in Analytical Chemistry", John Wiley and Sons, Inc., New York, 1957.
- [25] Price, W.B. and Meade, R.K., "The Technical Analysis of Brass and Nonferrous Alloys", John Wiley and Sons, Inc., New York, 1922.
- [26] Rodden, C.J., "Colorimetric Determination of Arsenic in Ferrous and Nonferrous Alloys", J. Res. Natl. Bur. Std., 24, 7 (1940).
- [27] Sandell, E.B., "Colorimetric Determination of Traces of Metals", 3rd edition, Interscience, New York, 1959.
- [28] Saywell, L.G. and Cunningham, B.B., "Determination of Iron by the Colorimetric o-phenanthroline Method", Ind. & Eng. Chem., Anal. Ed., 9, 67 (1937).
- [29] Skowronski, S., ASTM Bull. 174, 60 (May 1951).

- [30] Snell, Snell and Snell, "Colorimetric Methods of Analysis", D. Van Nostrand, Princeton, N.J., 1959.
- [31] Willard, H.H. and Diehl, H., "Advanced Quantitative Analysis", D. Van Nostrand, Princeton, N.J., 1943.
- [32] Willard, H.H. and Greathouse, L.H., "The Colorimetric Determination of Manganese by Oxidation with Periodate", J. Am. Chem. Soc., 39, 2366 (1917).
- [33] Woods, J.T. and Mellon, M.G., "Molybdenum Blue Reaction-Spectrophotometric Study", Ind. & Eng. Chem., Anal. Ed., 13, 760 (1941).