

# IEEE 1588 Workshop Tutorial

## Industrial and Motion Control Applications

Introduction to industrial automation

Communication networks

Applications

PROFINET

**SIEMENS**

# Automation hierarchy

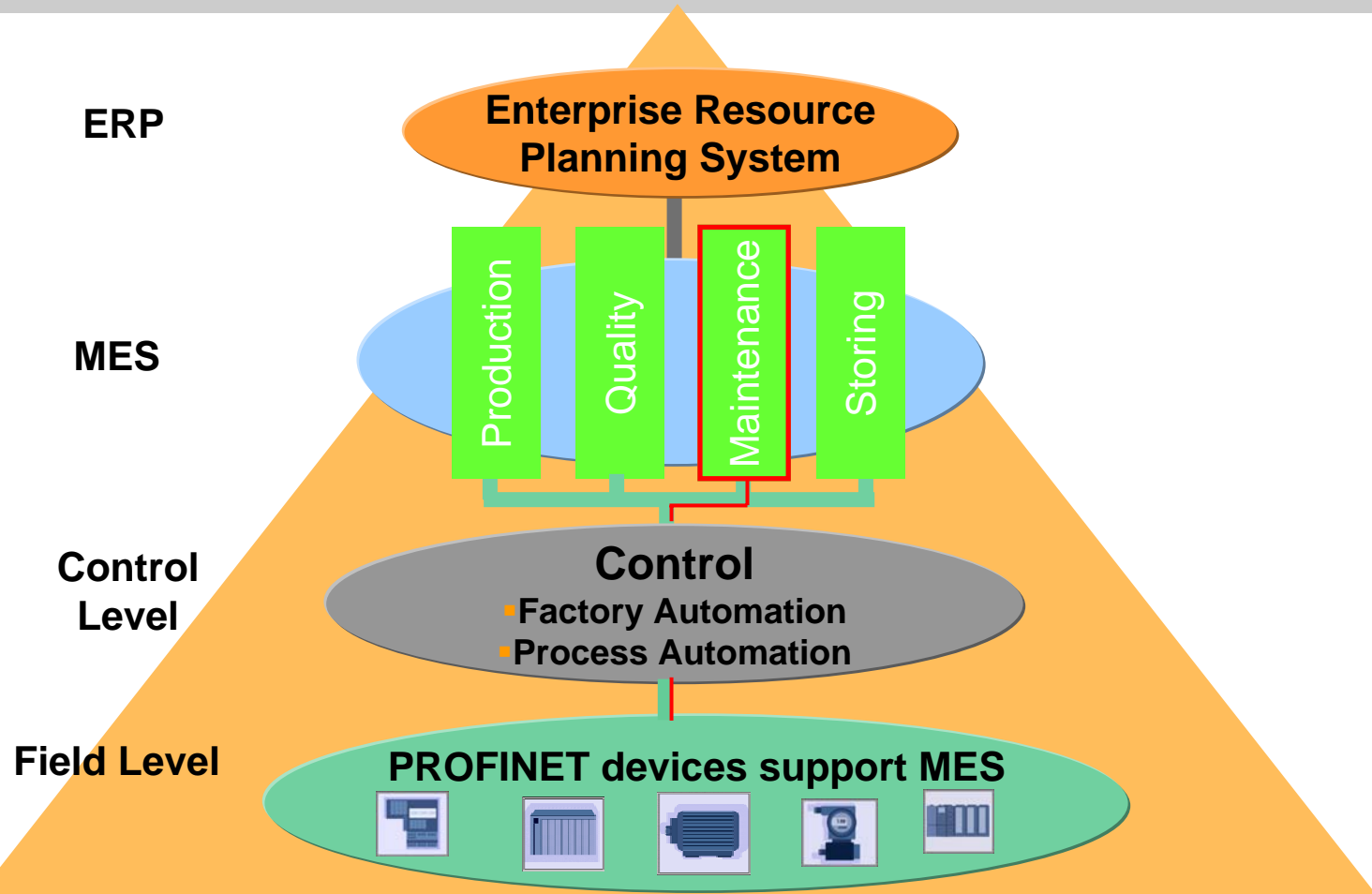

IEEE 1588

Industrial and Motion  
Control Applications

Introduction

Network

Applications

PROFINET

SIEMENS

# Distributed Automation – Plant View Modular Plant and Machine Construction

IEEE 1588

Industrial and Motion  
Control Applications

Introduction

Network

Applications

PROFINET

## ■ Example from the food & beverage industry:

- Wash bottles
- Fill bottles
- Close bottles
- Pack bottles

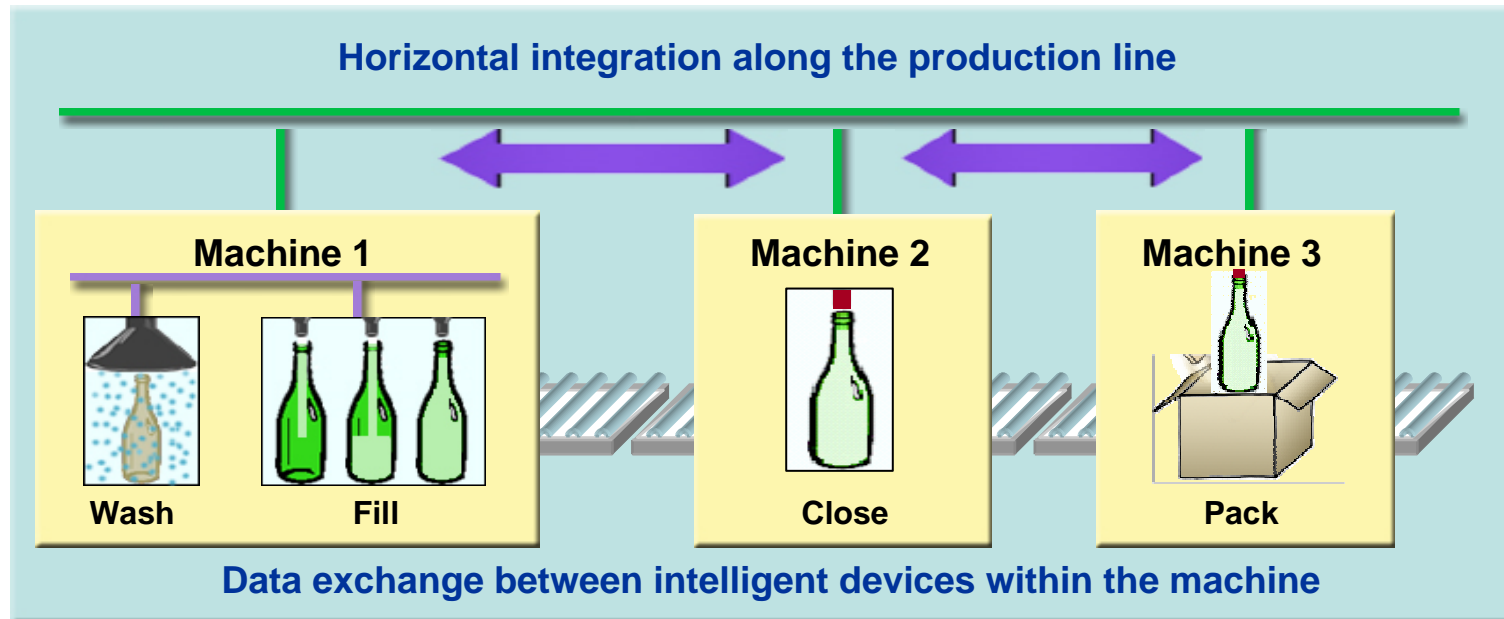

# Communication network Standards

## IEC/PAS 62411 and IEC 61784-2



**PROFI**  
INDUSTRIAL ETHERNET  
**NET**



**The Open  
Industrial Ethernet Standard  
For Automation**

**IEEE 1588**Industrial and Motion  
Control Applications

Introduction

**Network**

Applications

PROFINET

**SIEMENS**

# Real-Time Ethernet (RTE) with PROFINET

IEEE 1588

Industrial and Motion  
Control Applications

Introduction

Network

Applications

PROFINET

## PROFINET

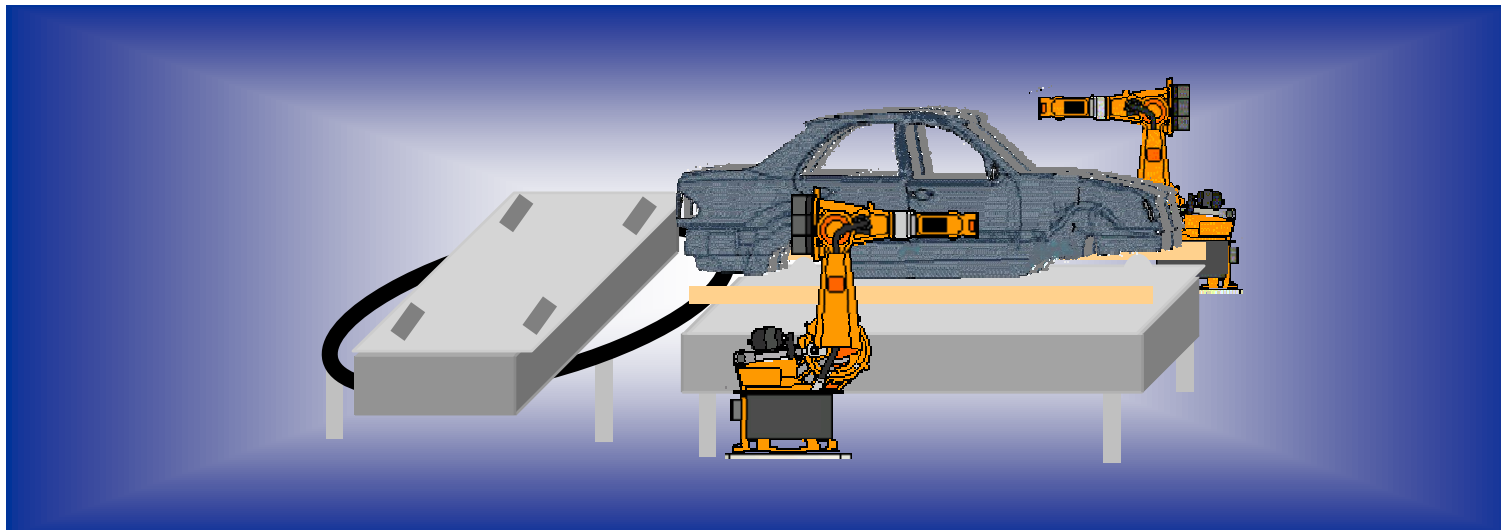

## Real-Time Communication

**SIEMENS**

# PROFINET CBA: Real-Time between Components

IEEE 1588

Industrial and Motion  
Control Applications

Introduction

Network

Applications

PROFINET

SIEMENS

- The user chooses the QoS „Real-Time Data Transmission“ in the configuration tool

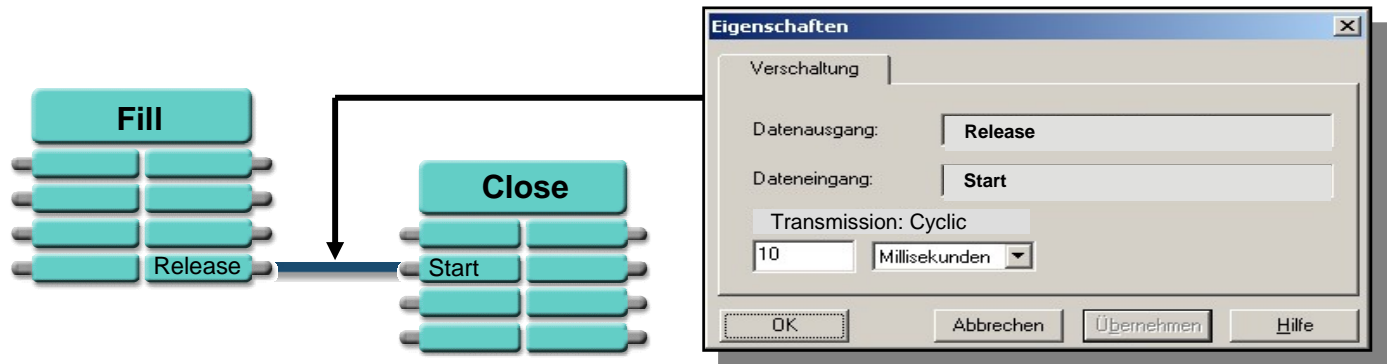

- The Communication relationships between the devices is established over TCP/IP
- Subsequently, process data are transmitted cyclically between devices via the Real-Time channel

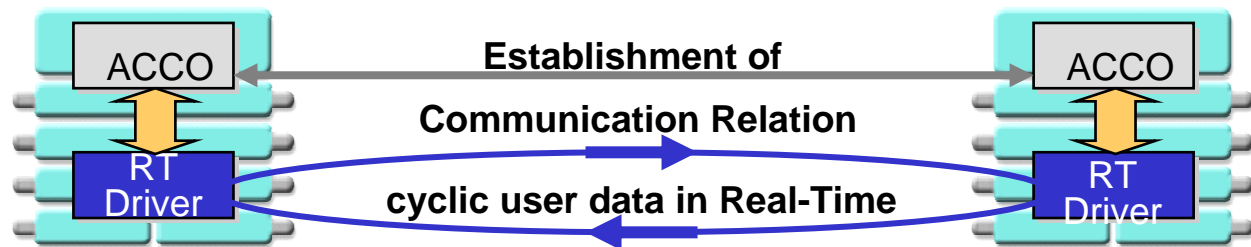

# Demands on Motion Control applications

**IEEE 1588**

Industrial and Motion  
Control Applications

Introduction

Network

Applications

PROFINET



**Wood-, glass-  
and ceramic-  
processing  
machines**



**Plastics  
injection  
molding  
machines**



**Packaging  
machines**



**Printing  
presses**

**SIEMENS**

# Trends

- **Time stamping from sensor level to HMI**
- **Precise clock synchronization**
  - With bridges (e.g. IE → PB) actually 10 ms plant wide
  - Industrial Ethernet (IE) actually 1 ms plant wide
  - Both are to enhance
- **Enhanced diagnosis required with precise time stamping**
- **A plant wide reliable synchronization source**
- **Robots synchronized using clock synchronization**
- **Clock synchronization protocols:**
  - NTP in cell level (HMI, EMS, ERP)
  - PTP (IEEE 1588) in field level (actor/sensor + control)

IEEE 1588

Industrial and Motion  
Control Applications

Introduction

Network

Applications

PROFINET

**SIEMENS**



# Application Requirements

## IEEE 1588

Industrial and Motion  
Control Applications

Introduction

Network

Applications

PROFINET

**SIEMENS**

- **Chronological association of diagnosis and process alarms**
- **Time dependent process synchronization**
  - **Net diagnosis on switch port with time stamp**
- **log files with time stamp**
  - **Security log files (IP-ACL)**
  - **Configuration log files**
  - **Device log files**
- **Clock synchronization precision plant wide below 1ms**
  - **IP-sub-net included**
- **Standby-Clock master**
- **Alerts for clock master failures**
- **Summer/Winter-time adjust independent of clock synchronization protocol**

# Real-Time Communication Classes

## IEEE 1588

Industrial and Motion  
Control Applications

Introduction

Network

Applications

**PROFINET**

- **PROFINET distinguishes between two real-time classes with differences regarding the performance:**
- **Real-Time:**
  - Using standard components
  - Performance characteristics like fieldbuses today (e.g. PROFIBUS)
  - Typical application area: Factory Automation
- **Isochronous Real-Time:**
  - Clock synchronized communication
  - Hardware support via Switch-ASIC
  - Typical application area: drive control in Motion Control applications

# Motion Control with PROFINET

IEEE 1588

Industrial and Motion  
Control Applications

Introduction

Network

Applications

PROFINET

## Advantages at a glance

- **Isochronous communication for Motion Control Applications**
- **Short and deterministic reaction times of  $< 1\text{ms}$ , Jitter  $< 1\mu\text{s}$**
- **Integration of decentralized field devices**
- **TCP/IP for engineering, diagnostics and HMI connection**

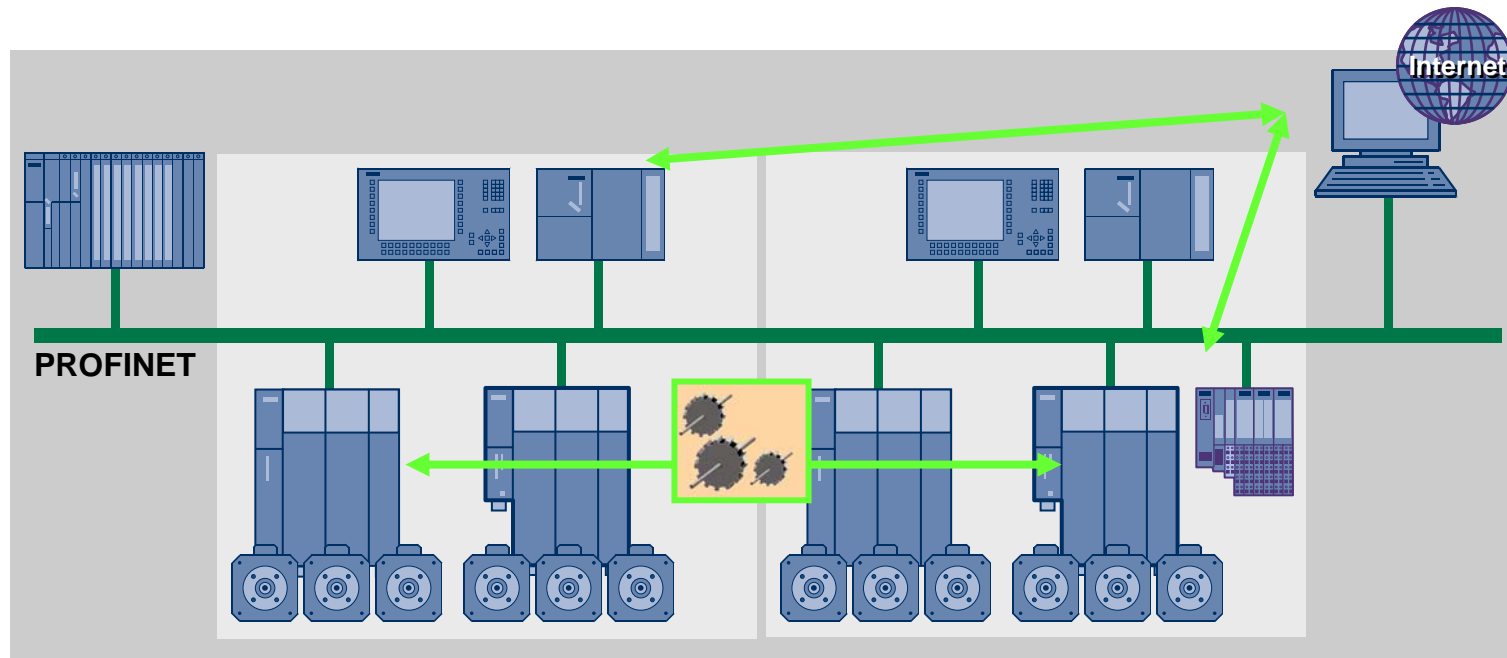

SIEMENS

# Isochronous Real-Time Communication (IRT)

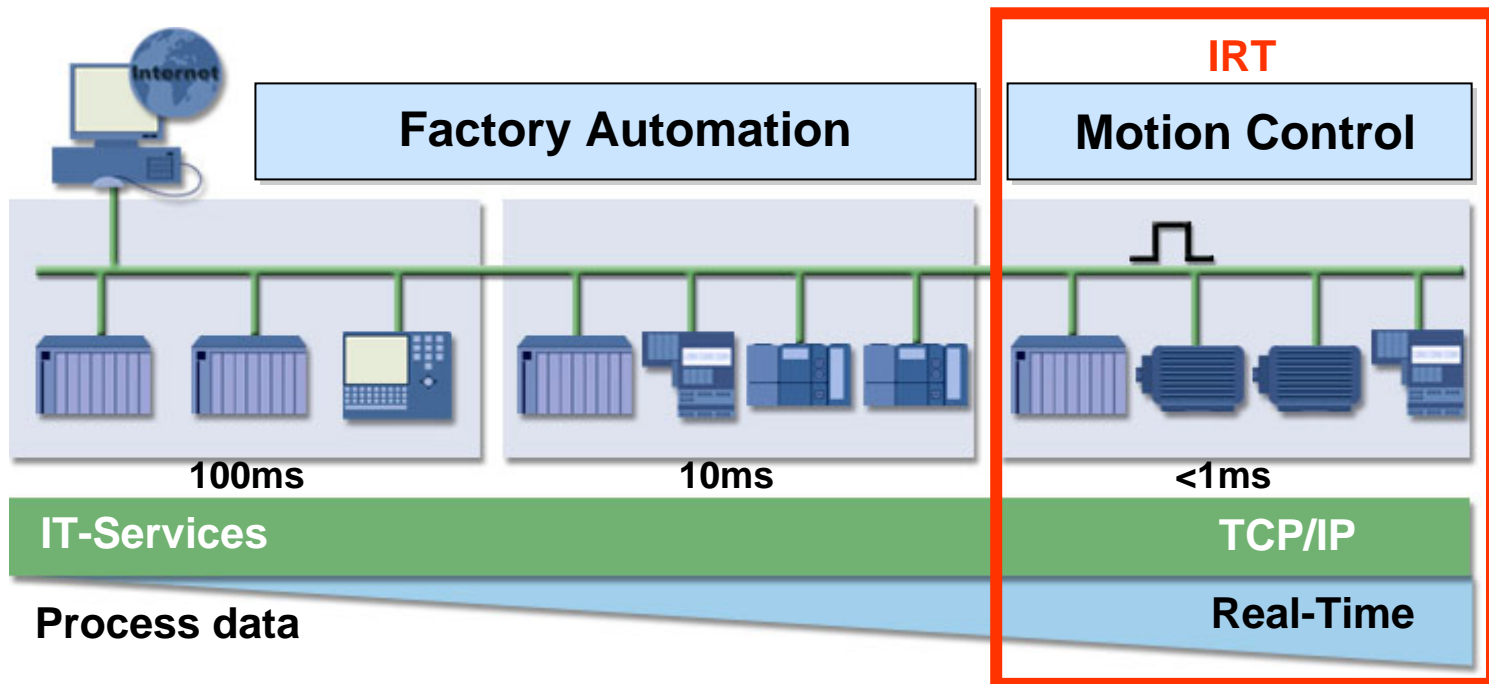

## ■ Requirements on Ethernet for Motion Control

- Highest performance
- Time synchronization inclusive determinism
- Openness for unrestricted access to the IT world, which means no restrictions for TCP/IP

IEEE 1588

Industrial and Motion  
Control Applications

Introduction

Network

Applications

PROFINET

# PROFINET and IRT

## IEEE 1588

Industrial and Motion  
Control Applications

Introduction

Network

Applications

**PROFINET**

## What are the pre-conditions ?

- **Segmentation of the communication**
- **use of time based communication**
- **Clock-Synchronization**

# IRT Scheduling

IEEE 1588

Industrial and Motion  
Control Applications

Introduction

Network

Applications

PROFINET

- **Scheduling of communication systems**
  - **High accurate cycle synchronization**
  - **Separate time areas for real-time and TCP/UDP**

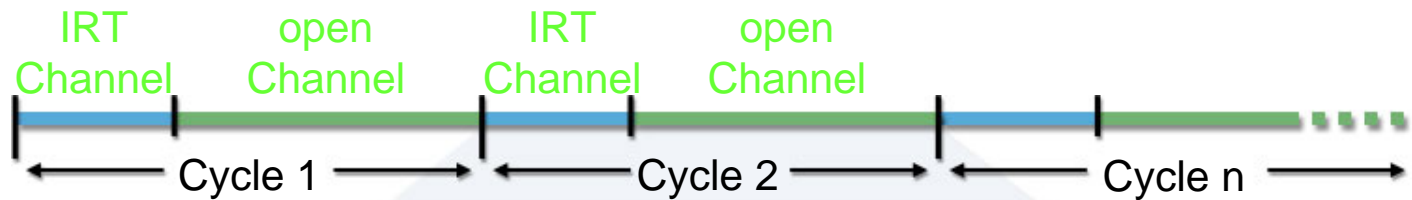

E.g. 1 ms position control cycle

